

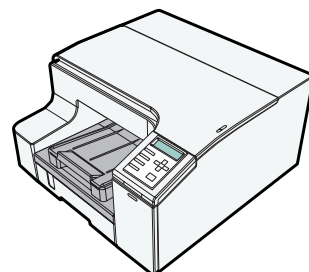

# GelSprinter GX e5550N

## User Guide



- 
- 1** Read This First
  - 2** Preparing for Printing
  - 3** Printer Driver
  - 4** Monitoring and Configuring the Printer
  - 5** Using the Printer with a Macintosh
  - 6** Maintaining
  - 7** Troubleshooting
  - 8** Appendix



# TABLE OF CONTENTS

---

## 1. Read This First

---

|  |    |
|--|----|
| About This Product.....                              | 9  |
| Introduction.....                                    | 9  |
| Legal Prohibition.....                               | 9  |
| Trademarks.....                                      | 9  |
| Disclaimer.....                                      | 11 |
| User's Notes.....                                    | 11 |
| Manuals for This Printer.....                        | 13 |
| How to Read This Manual.....                         | 15 |
| Description for the Specified Model.....             | 15 |
| Symbols.....   | 16 |
| Installing User Guide.....                           | 16 |
| How to Use User Guide.....                           | 17 |
| Removing the User Guide.....                         | 19 |
| Guide to Components.....                             | 20 |
| Machine Body.....                                    | 20 |
| Machine Rear.....                                    | 21 |
| Control Panel.....                                   | 22 |
| Making Printer Settings Using the Control Panel..... | 25 |
| Options.....   | 30 |
| Paper Feed Unit TK1110.....                          | 30 |
| Multi Bypass Tray BY1000.....                        | 31 |
| Recommended Functions.....                           | 33 |

## 2. Preparing for Printing

---

|   |    |
|---|----|
| Setting Up the Hardware.....  | 35 |
| Checking the Computer and Installation Area.....                          | 35 |
| Checking the Supplied Items and Unpacking the Printer.....                | 37 |
| Attaching the Options.....  | 39 |
| Installing the Print Cartridges.....                                      | 40 |
| Plugging in the Power Cord and Turning the Power On.....                  | 42 |
| Loading Paper.....  | 44 |
| Printing a Configuration Page.....  | 54 |
| Connecting the Computer and Installing the Software (USB Connection)..... | 56 |

---

|  |    |
|--|----|
| Before Installing the Software (USB).....  | 56 |
| Quick Install for USB.....   | 57 |
| Connecting the Computer and Installing the Software (Network Connection).....                              | 60 |
| Before Installing the Software (Network Connection).....   | 60 |
| Quick Install for Network.....   | 63 |
| Checking the Printer Status and Settings using the Printer's Control Panel (List/Test Print Menu).....     | 65 |
| Interpreting the Configuration Page.....   | 65 |
| Confirming the Connection Method.....  | 66 |
| Installing the PCL or RPCS Raster Printer Driver (USB).....  | 68 |
| Sharing the Printer.....   | 70 |
| Specifying the Interface and Network Settings using the Printer's Control Panel (Host Interface Menu)..... | 73 |
| Changing the Host Interface Menu.....  | 75 |
| Installing the Drivers for Network Connection.....   | 76 |
| Installing the PCL or RPCS Raster Printer Driver (Network).....  | 77 |
| Installing the DeskTopBinder - SmartDeviceMonitor for Client .....   | 82 |
| Paper.....   | 84 |
| Compatible Paper Types.....  | 84 |
| Loadable Paper Sizes and Quantities.....   | 84 |
| Paper Handling Precautions.....  | 87 |
| Specifying the Paper Settings using the Printer's Control Panel (Paper Input Menu).....                    | 94 |
| Changing the Paper Input Menu.....   | 94 |

### **3. Printer Driver**

---

|  |     |
|--|-----|
| Two Types of Printer Properties Dialog Box.....  | 97  |
| Opening the Printer Properties Dialog Box.....   | 97  |
| Opening the Printing Preferences Dialog Box..... | 97  |
| Opening from an Application.....                 | 98  |
| Specifying Settings on [Accessories] Tab.....    | 99  |
| Conditions for Bidirectional Communication.....  | 99  |
| If Bidirectional Communication is Disabled.....  | 99  |
| Printing.....                                    | 101 |
| Unauthorized Copy Control.....                   | 102 |
| Canceling Printing.....                          | 104 |

---

|  |     |
|--|-----|
| Canceling Printing from the Status Monitor.....                  | 104 |
| Canceling Printing Using the [Job Reset] Key of the Printer..... | 104 |
| Canceling Printing from the Taskbar.....                         | 105 |
| Selecting the Printer Driver Language.....                       | 106 |

#### **4. Monitoring and Configuring the Printer**

---

|  |     |
|--|-----|
| Using the Status Monitor.....  | 109 |
| Receiving Notification of Print Job Status via the Status Monitor..... | 109 |
| Using SmartDeviceMonitor for Client.....                               | 110 |
| Using Notification via SmartDeviceMonitor for Client.....              | 111 |
| Specifying the Settings for Monitoring the Printer.....                | 112 |
| Displaying the Printer Status.....                                     | 113 |
| Using Web Browser.....   | 114 |
| Displaying Top Page.....   | 114 |
| Menu.....  | 116 |
| Checking the Printer Status.....                                       | 116 |
| Changing the Printer Settings.....                                     | 116 |
| Notifying the Printer Status by E-mail.....                            | 117 |
| About the Web Browser Help.....  | 129 |
| SNMP.....  | 130 |

#### **5. Using the Printer with a Macintosh**

---

|   |     |
|---|-----|
| System Requirements for Macintosh.....                                  | 131 |
| Operating System (for Macintosh).....                                   | 131 |
| Hardware (for Macintosh).....   | 131 |
| Preparing for Printing (for Macintosh).....                             | 132 |
| Installing the Printer Driver under Mac OS X.....                       | 133 |
| Installing the Printer Driver on a Macintosh.....                       | 133 |
| Specifying the Printer Settings on a Macintosh.....                     | 134 |
| Printer Properties Dialog Box on a Macintosh.....                       | 137 |
| Dialog Boxes for Printer Settings on a Macintosh.....                   | 137 |
| Displaying the Printer Driver Settings Dialog Boxes on a Macintosh..... | 137 |
| Printing with a Macintosh.....  | 140 |
| Basic Printing Procedure for Macintosh.....                             | 140 |
| Printing on Various Paper Types with a Macintosh.....                   | 140 |

---

|   |     |
|---|-----|
| Canceling a Print Job on a Macintosh.....                                   | 144 |
| Monitoring and Configuring the Printer (for Macintosh).....                 | 146 |
| Displaying the Printer Status on a Macintosh.....                           | 147 |
| Checking whether Bidirectional Communication is Working on a Macintosh..... | 147 |
| Displaying the Status Monitor on a Macintosh.....                           | 147 |
| Opening Help on a Macintosh.....  | 149 |
| Displaying Help from the Print dialog on a Macintosh.....                   | 149 |
| Displaying Mac Help.....  | 149 |
| Maintaining (for Macintosh).....  | 150 |
| Troubleshooting (for Macintosh).....  | 151 |
| Updating the Printer Driver on a Macintosh.....                             | 152 |
| Checking the Version of the Printer Driver on a Macintosh.....              | 152 |
| Uninstalling the Printer Driver from a Macintosh.....                       | 152 |
| Software on the CD-ROM for Macintosh.....                                   | 154 |
| Files for Macintosh.....  | 154 |
| RPCS Raster Printer Drivers for Macintosh.....                              | 154 |
| Manuals (HTML files) for Macintosh.....                                     | 155 |

## 6. Maintaining

---

|  |     |
|--|-----|
| Checking the Number of Printed Pages using the Control Panel (Counter Menu)..... | 157 |
| Displaying the Counter.....  | 157 |
| Performing Maintenance using the Control Panel (Maintenance Menu).....           | 159 |
| Nozzle Check.....  | 160 |
| Head-cleaning.....   | 162 |
| Head-flushing.....   | 165 |
| Head Position.....   | 166 |
| Adj.Paper Feed.....  | 168 |
| Registration.....  | 170 |
| Setting the Date and Time.....   | 173 |
| De-condensation.....   | 176 |
| Specifying System Settings using the Control Panel (System Menu).....            | 178 |
| Changing the System Menu.....  | 182 |
| Specifying PCL Settings using the Control Panel (PCL Menu).....                  | 184 |
| Changing the PCL Menu.....   | 186 |

---

|   |     |
|---|-----|
| Selecting the Control Panel Language.....     | 187 |
| Restricting Printer Functions.....            | 189 |
| Locking the Keys.....                         | 189 |
| Unlocking the Keys.....                       | 189 |
| Replacing a Print Cartridge.....              | 191 |
| Checking the Remaining Ink.....               | 191 |
| Replacing a Print Cartridge.....              | 193 |
| Handling Print Cartridges.....                | 195 |
| Replacing an Ink Collector Unit.....          | 197 |
| Cleaning.....                                 | 200 |
| Cleaning the power Cable Plug.....            | 200 |
| Moving.....                                   | 201 |
| Moving a Short Distance.....                  | 201 |
| Moving a Long Distance.....                   | 201 |
| Disposing.....                                | 203 |
| When Not Using for a Long Period of Time..... | 204 |

## 7. Troubleshooting

---

|   |     |
|---|-----|
| Software Cannot Be Installed.....                     | 205 |
| Confirming Installation.....                          | 205 |
| Checking Your Computer Environment.....               | 205 |
| Printer Driver Cannot Be Installed.....               | 207 |
| USB Connection is not Automatically Detected.....     | 208 |
| If Test Print Fails.....                              | 209 |
| Uninstalling.....                                     | 210 |
| Uninstalling the Printer Driver.....                  | 210 |
| Deleting Devices.....                                 | 211 |
| Printing Will Not Start.....                          | 213 |
| Power Cannot Be Turned On.....                        | 213 |
| Paper Will Not Feed Even When the Power Is On.....    | 213 |
| An Error Occurs.....                                  | 213 |
| Paper Is Not Fed or Delivered Normally.....           | 215 |
| Paper Jam.....  | 217 |
| Using the [Form Feed] Key to Remove Jammed Paper..... | 217 |

---

|   |     |
|---|-----|
| Removing Paper Jammed in Tray 1 .....                           | 218 |
| Removing Paper Jammed in Tray 2/Tray 3 (optional).....          | 220 |
| Removing Paper Jammed in the Rear Unit (optional).....          | 222 |
| Removing Paper Jammed in the Multi Bypass Tray (optional).....  | 223 |
| Removing Paper Jammed under the Top Cover.....                  | 227 |
| Removing Paper Jammed around the Guide Board.....               | 230 |
| Removing Paper Jammed in the Duplex Unit.....                   | 234 |
| If You Cannot Remove Jammed Paper.....                          | 237 |
| Print Results Are Not Satisfactory.....                         | 241 |
| Prints are Unsatisfactory.....                                  | 241 |
| Colors Do Not Match the Displayed Image.....                    | 243 |
| Positions Do Not Match the Displayed Image.....                 | 243 |
| Other Problems.....   | 244 |
| Checking the Consumables.....                                   | 246 |
| If a Message Appears during Installation.....                   | 247 |
| Error & Status Messages on the Control Panel.....               | 248 |
| Control Panel Error Messages.....                               | 248 |
| Status Monitor Errors.....                                      | 254 |
| Status Monitor Does Not Open.....                               | 254 |
| No Response from Printer.....                                   | 254 |
| No Paper/Tray Not Detected (Tray 1).....                        | 254 |
| No Paper/Tray Not Detected (Tray 2/Tray 3).....                 | 256 |
| No Paper/Tray Not Detected (Bypass Tray).....                   | 258 |
| Paper Size Mismatch/Paper Type Mismatch (Tray 1).....           | 260 |
| Paper Size Mismatch/Paper Type Mismatch (Tray 2/Tray 3).....    | 261 |
| Paper Size Mismatch/Paper Type Mismatch (Bypass Tray).....      | 263 |
| Paper Size Mismatch/Paper Type Mismatch (Auto Tray Select)..... | 265 |
| Cover Open.....   | 267 |
| Cover Open / Print Cartridge(s) Not Detected.....               | 269 |
| Duplex Unit Not Detected.....                                   | 271 |
| Rear Unit of Optional Tray Not Detected.....                    | 271 |
| Cartridge Almost Empty.....                                     | 272 |
| Cartridge Empty.....  | 273 |



---

|  |     |
|--|-----|
| Used Cartridge.....                      | 274 |
| Ink Collector Unit Not Detected.....     | 275 |
| Ink Collector Unit Almost Full.....      | 277 |
| Ink Collector Unit Full.....             | 277 |
| Used Ink Collector Unit.....             | 277 |
| Out of Printable Temperature Range.....  | 278 |
| Printer Error.....                       | 278 |
| Network Interface Error.....             | 279 |
| Envelope Selector Position Mismatch..... | 279 |
| Maintenance Failed.....                  | 282 |
| Cannot Recover Error Page.....           | 282 |

## 8. Appendix

---

|   |     |
|---|-----|
| Updating the Firmware.....                                | 285 |
| Checking the Current Printer Driver Version.....          | 286 |
| Software on the CD-ROM.....                               | 287 |
| Files.....  | 287 |
| RPCS Raster Printer Drivers.....                          | 287 |
| PCL Printer Drivers.....                                  | 288 |
| SmartDeviceMonitor for Client.....                        | 288 |
| Manuals (HTML files).....                                 | 289 |
| Cautions to Take When Using in a Network.....             | 290 |
| Using DHCP.....   | 290 |
| Electromagnetic Interference.....                         | 291 |
| Specifications.....                                       | 292 |
| Printer Body.....   | 292 |
| Option (Paper Feed Unit).....                             | 294 |
| Option (Bypass tray).....                                 | 295 |
| List of Printer Driver Functions (Windows/Macintosh)..... | 296 |
| Information about Installed Applications.....             | 311 |
| expat.....  | 311 |
| MD5.....  | 311 |
| NetBSD.....   | 312 |
| Original SSLeay License.....                              | 314 |

---

|                                      |     |
|--------------------------------------|-----|
| TCP/IP.....                          | 315 |
| JPEG LIBRARY.....                    | 315 |
| IPSTM print language emulations..... | 315 |
| Where to Inquire.....                | 316 |
| Recommended Consumables.....         | 317 |
| Option and Consumables.....          | 318 |
| <b>INDEX</b> .....                   | 319 |

# 1. Read This First

---

## About This Product

This section tells you about the product.

1

---

### Introduction

---

This manual describes detailed instructions on the operation and notes about the use of this machine. To get maximum versatility from this machine, all operators are requested to read this manual carefully and follow the instructions. Please keep this manual in a handy place near the machine.

For safe and correct use, please be sure to read the Safety Information in the "Safety Information" that comes with this machine before using the machine.

---

### Legal Prohibition

---

Do not copy or print any item for which reproduction is prohibited by law.

Copying or printing the following items is generally prohibited by local law:

bank notes, revenue stamps, bonds, stock certificates, bank drafts, checks, passports, driver's licenses.

The preceding list is meant as a guide only and is not inclusive. We assume no responsibility for its completeness or accuracy. If you have any questions concerning the legality of copying or printing certain items, consult with your legal advisor.

---

### Trademarks

---

Microsoft, Windows are registered trademarks of Microsoft Corporation in the United States and/or other countries.

Adobe, Flash, Macromedia and Reader are either registered trademarks or trademarks of Adobe Systems Incorporated in the United States and/or other countries.

PCL is a registered trademark of Hewlett-Packard Company.

Monotype is a registered trademark of Monotype Imaging, Inc.

UNIX is a registered trademark in the United States and other countries, licensed exclusively through X/Open Company Limited.

Netscape is a registered trademark of Netscape Communication Corporation in the U.S. and/or other countries.

AppleTalk, ColorSync, Mac OS, Macintosh, and Power Mac are registered trademarks of Apple Inc., registered in the U.S. and other countries.

Intel and Intel Core are registered trademarks of Intel Corporation or its subsidiaries in the United States and other countries.

PowerPC is a registered trademark of International Business Machines Corporation in the United States and other countries.

Other product names used herein are for identification purposes only and might be trademarks of their respective companies. We disclaim any and all rights to those marks.

- The product names of Windows 2000 are as follows:
  - Microsoft® Windows® 2000 Professional
  - Microsoft® Windows® 2000 Server
  - Microsoft® Windows® 2000 Advanced Server
- The product names of Windows XP are as follows:
  - Microsoft® Windows® XP Professional
  - Microsoft® Windows® XP Home Edition
  - Microsoft® Windows® XP Media Center Edition
  - Microsoft® Windows® XP Tablet PC Edition
- The product names of Windows Vista are as follows:
  - Microsoft® Windows Vista® Ultimate
  - Microsoft® Windows Vista® Business
  - Microsoft® Windows Vista® Home Premium
  - Microsoft® Windows Vista® Home Basic
  - Microsoft® Windows Vista® Enterprise
- The product names of Windows Server 2003 are as follows:
  - Microsoft® Windows Server® 2003 Standard Edition
  - Microsoft® Windows Server® 2003 Enterprise Edition
  - Microsoft® Windows Server® 2003 Web Edition
  - Microsoft® Windows Server® 2003 Datacenter Edition
- The product names of Windows Server 2003 R2 are as follows:
  - Microsoft® Windows Server® 2003 R2 Standard Edition
  - Microsoft® Windows Server® 2003 R2 Enterprise Edition
  - Microsoft® Windows Server® 2003 R2 Datacenter Edition
- The product names of Windows Server 2008 are as follows:
  - Microsoft® Windows Server® 2008 Standard

Microsoft® Windows Server® 2008 Enterprise  
Microsoft® Windows Server® 2008 Datacenter  
Microsoft® Windows Server® 2008 for Itanium-based Systems  
Microsoft® Windows® Web Server 2008  
Microsoft® Windows® HPC Server 2008  
Microsoft® Windows Server® 2008 Standard without Hyper-V™  
Microsoft® Windows Server® 2008 Enterprise without Hyper-V™  
Microsoft® Windows Server® 2008 Datacenter without Hyper-V™

---

## Disclaimer

---

Contents of this manual are subject to change without prior notice.

In no event will the company be liable for direct, indirect, special, incidental, or consequential damages as a result of handling or operating the machine.

For good print quality, the supplier recommends that you use genuine print cartridges from the supplier.

The supplier shall not be responsible for any damage or expense that might result from the use of parts other than genuine parts from the supplier with your office products.

---

## User's Notes

---

- High temperatures inside the printer can cause a breakdown. Do not lean anything against the vent or block it in any way.

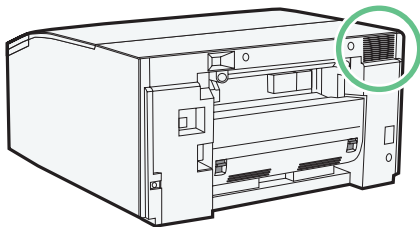

BUG100S

- Warm air from the vent is normal and not a cause for concern.
- Do not leave the left, top, or right front cover open. If you do, dust or other matter might get inside the printer, and this will reduce print quality.
- During printing, do not move the printer or open its covers.
- Do not open the left, top, or right front cover during printing. If you do, printing will stop.

- During printing, do not pull out a paper tray. Printing will stop and the paper will jam.
- Do not touch the feed belt, the transparent black band, print head rail rod, ink tubes, paper pressing board, or the toothed rubber belt. Also, take care not to snag any cables or ink tubes with your sleeves.

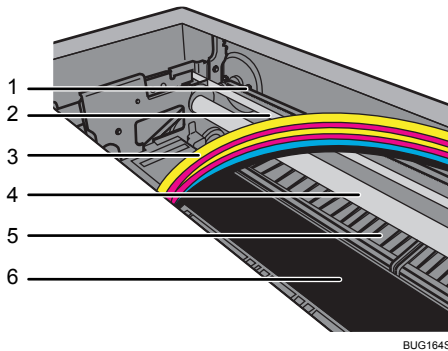

1. **Toothed rubber belt**
2. **Transparent black band**
3. **Ink tubes**
4. **Print head rail rod**
5. **Paper pressing board**
6. **Feed belt**

- Take care not to let paper clips and other foreign objects fall inside the printer.
- After you install the print cartridge and switch the printer on for the first time, the print head priming process will begin. This process sometimes clogs the print head. If this happens, perform the head cleaning procedure.
- During printing, do not turn off the power or unplug the power cord from the wall outlet.
- During printing, do not subject the printer to external shock such as that caused by tapping paper on it.
- When not using the printer, turn off the power.
- You can place up to 20 kg (44.1 lb.) of evenly spread weight on the printer. Do not place any concentrated weight of more than 5 kg (11.1 lb.) on the printer.
- Do not place unsteady objects on the printer. If they fall, they will cause injury to users and/or damage to the printer.
- This printer has a nominal operational life of 5 years if used normally for 12 hours a day to produce up to 3,300 A4 prints a month. Exceeding these limits may reduce the operational life. The operational life also depends on the environment in which the printer is used.
- "Total Counter" displays the number of pages printed. Use "Total Counter" to estimate the number of pages that can be printed within the printer's remaining operational life. The printer's operational life is calculated based on the number of pages that it can print on plain paper in [Speed priority] mode.

- This printer is designed to have an operational life of 5 years or be good for 200,000 pages.
- Depending on your printing document, the ink collector unit may fill up sooner than normal.  
An "Ink Collector almost full" message appears shortly before the ink collector unit is full. Although the printer remains usable until the unit is completely full, contact your sales or service representative as early as possible (charge incurred).
- Print cartridges should be used up before their expiry date, ideally within six months of being removed from their packaging.
- Cartridges that are no longer usable for printing reserve a small quantity of ink for maintenance usage.
- Print cartridges and supplies comply with the manufacturer's safety specifications. To ensure safety and reliability, use genuine print cartridges and supplies.
- Single-sided copies are printed at higher density than duplex-printed copies.
- For print quality and consistency, this printer always uses all the available ink colors (black, cyan, yellow, and magenta) to produce print images. Even if your print image is black and white or [Black and White] is selected in the printer properties dialog box, all ink colors will still be used.
- Printing stops if one of the print cartridges becomes empty. If a cartridge containing a color ink such as cyan, yellow, or magenta becomes empty, you cannot print, even in black/white. If a message prompting you to change the print cartridge appears, change the cartridge as soon as possible.
- Printing hundreds of copies in a single day might cause the print head to clog the following day. If this happens, perform the head cleaning procedure.
- This printer performs regular automatic maintenance, after and during printing, to ensure consistent print quality. Maintenance is also performed when printing begins after a period of disuse.
- Color ink may be used even if you print all-black text or if you specify black and white printing. It may also be used for print head cleaning and refreshing, which are done to maintain printer performance.
- If the printer will not be used for a long time, turn its power off, disconnect the USB cable, and unplug the power cord from the wall outlet. Because the printer consumes a lot of ink for maintenance and print head cleaning when switched on after a long period of inactivity, we recommended you use the printer at least once a month.
- Do not move the printer while it is powered. Even when it is off, make sure the printer is on a level surface and safe from shock and vibration.
- Do not switch the printer off while it is busy. Make sure the printer is idle before switching it off.
- Condensation can form inside the printer if it is moved from a cold place to a warm place. Allow any condensation to fully evaporate by not switching the printer on for at least an hour after moving it.

---

## Manuals for This Printer

---

Read the appropriate manual according to what you want to do.

## **Quick Installation Guide**

This guide briefly explains how to unpack and install the printer.

## **User Guide (HTML)**

This guide, which is on the CD-ROM, explains in detail how to use the printer.

The guide explains how to make network and printer driver settings, and how to make and check printer settings using a Web browser and other utilities.

The guide also contains troubleshooting procedures, such as those related to printing and paper jams, and important information about types of paper and replacing consumables.

We recommend you install this guide on your computer so you can refer to it easily.

## **Safety Information**

This booklet contains important information about using the machine safely and correctly. Be sure to read this before using the machine.



# How to Read This Manual

Be sure to read this section before anything else.

- This guide uses Windows XP procedures for its examples. Procedures and screens might vary depending on the operating system you are using.

The color samples in this manual may differ slightly from the colors of actual copies.

Some illustrations in this manual might be slightly different from the machine.

Certain options might not be available in some countries. For details, please contact your local dealer.

Depending on which country you are in, certain units may be optional. For details, please contact your local dealer.

This printer supports the PCL and RPCS Raster printer drivers.

1

## Description for the Specified Model

In this manual, the following items explain about the machine for the specified models:

**-22, -27**

Information under these numbers is applicable to J018-22 and J018-27 models. You can identify the model code by checking the label on the rear of the machine.

Read if you purchase this model.

**-17**

Information under this number is applicable to J018-17 model. You can identify the model code by checking the label on the rear of the machine.

Read if you purchase this model.

### ↓ Note

- You can identify the machine's model code by checking the label on the rear of the machine as shown.

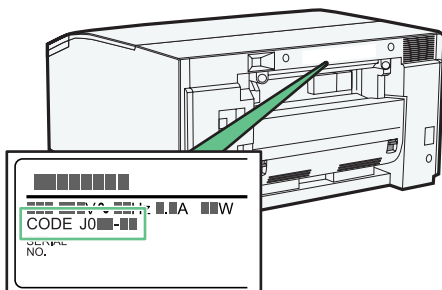

BUG101S

---

## Symbols

---

The following set of symbols is used in this manual.

### **Important**

Indicates points to pay attention to when using the machine, and explanations of likely causes of paper misfeeds, damage to originals, or loss of data. Be sure to read these explanations.

### **Note**

Indicates supplementary explanations of the machine's functions, and instructions on resolving user errors.

### **Reference**

This symbol is located at the end of sections.

It indicates where you can find further relevant information.

[ ]

Indicates the names of keys and buttons.

---

## Installing User Guide

---

Follow the procedure below to install User Guide only.

If you installed the software when performing [Quick Install for USB] or [Quick Install for Network], there is no need to install it again here.

### **Important**

- The following explanation uses Windows XP as an example. Procedures under other operating systems may differ.
- Screens vary according to the operating environment.

#### 1. Start Windows, and insert the provided CD-ROM into the CD-ROM drive.

Quit all other applications currently running.

After inserting the CD-ROM, the [Printer Drivers, Manuals, Utilities] dialog box appears. If it does not, double-click the CD-ROM drive icon under [My Computer] or [Explorer], and then double-click [SETUP.EXE].

#### 2. Select a language for the interface, and then click [OK].

#### 3. Click [User Guide].

#### 4. Read the entire license agreement carefully. If you accept its terms, click [I accept the agreement.], and then click [Next >].

#### 5. Confirm the location in which you want to install User Guide, and then click [Next >].

To change the installation location, click [Change...].

6. Confirm the program folder in which you want to install User Guide, and then click [Next >].

7. Click [Install].

Installation starts.

During installation, a message asking whether you want to create a desktop shortcut icon is displayed. Click [Yes] or [No] as appropriate.

8. When installation is complete, click [Finish].

#### Reference

- To use the printer, the printer driver must be installed. See p.68 "Installing the PCL or RPCS Raster Printer Driver (USB)".

---

## How to Use User Guide

---

User Guide (on the provided CD-ROM) includes detailed information about this printer and a troubleshooting guide.

Use one of the browsers below to display User Guide.

- Windows:  
Microsoft Internet Explorer Version 4.01 SP2 or later
- MacOS  
Microsoft Internet Explorer Version 5 or later

When using Safari, a simplified User Guide is displayed.

To view the video files of User Guide, Adobe Flash Player (Macromedia Flash Player 5 or later) plug-in is required.

### **When using screen reader software or when you cannot install Adobe Flash Player (Macromedia Flash Player 5 or later) plug-ins**

When using screen reader software to listen to User Guide or when video files cannot be displayed because Flash plug-ins cannot be installed, click [For screen reader] to display User Guide version optimized for screen reader software.

Use the button in the upper right window to change the screen.

### **When using a non-recommended browser**

When using Internet Explorer 3.02 or Netscape Navigator 4.05 or later versions, a simplified User Guide is displayed.

#### Note

- If the simplified User Guide does not automatically appear, in the CD-ROM's [unv] folder, open index.htm.

## Opening from the Icon

---

This section explains how to open User Guide from the desktop icon.

1. **Double-click the User Guide icon on your desktop.**



The browser opens, and then User Guide appears.

## Opening from the [Start] Menu

---

This section explains how to open User Guide from the Windows Start menu.

1. **On the [Start] menu, point to [All Programs], point to [Product Name], and then click [Product Name User Guide].**

The browser opens, and then User Guide appears.

### ↓ Note

- Depending on the settings made during installation, menu folder names may differ.

## Opening from the Printer Driver

---

This section explains how to open User Guide from the printer driver.

1. **In the printer properties dialog box, click [User Guide] on the [Setup] tab.**

The browser opens, and then User Guide appears.

## Opening from the CD-ROM

---

This section explains how to open User Guide from the supplied CD-ROM.

1. **Start Windows, and insert the provided CD-ROM into the CD-ROM drive.**

After inserting the CD-ROM, the [Printer Drivers, Manuals, Utilities] dialog box appears. If it does not, double-click the CD-ROM drive icon under [My Computer] or [Explorer], and then double-click [SETUP.EXE].

2. **Select a language for the interface, and then click [OK].**
3. **Click [Browse User Guide].**

The browser opens, and then User Guide appears.

---

## Opening from Printer Status Error Messages

---

This section explains how to open User Guide when Printer Status error message is displayed.

1. The Status monitor displays an error message if a problem occurs.
2. Click [User Guide].

The browser opens, and then User Guide appears.

Open User Guide from here if a problem occurs while using the printer.

---

## Removing the User Guide

---

Follow the procedure below to remove the User Guide installed on your computer.

### Removing the User Guide using its [Uninstall] function

1. On [Start] menu, point to [All Programs].
2. Point to the installed [Product name], and then click [Uninstall User Guide].
3. Follow the instructions that appear to remove the User Guide.

### Removing the User Guide using [Add/Remove Programs]

1. On [Start] menu, click [Control Panel].
2. Click [Add or Remove Programs].
3. Select the installed [Product name User Guide], and then click [Remove].
4. Follow the instructions that appear to remove the User Guide.

# Guide to Components

The names and functions of parts of the printer body, control panel, and options are explained.

1

## Machine Body

This is a front view of the printer.

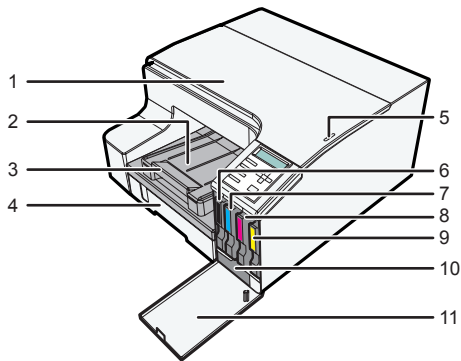

BUG102S

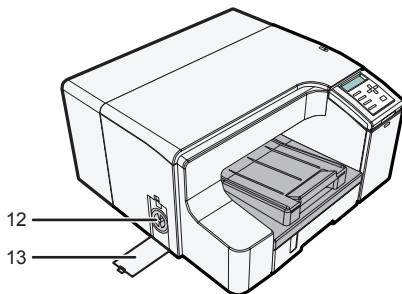

BUG103S

### 1. Top Cover

Normally, keep this cover closed. If you cannot locate paper jams, or jammed paper cannot be removed easily, you can check the condition of paper from the top of the printer.

### 2. Output Ramp

Prints are delivered on the output ramp.

### 3. Output Ramp Extension

Pull out when using large paper to keep the printed paper from falling.

### 4. Tray 1

Load paper here.

If you want to print on paper larger than A4 or letter size, pull the tray extension out.

**5. Envelope Selector**

For envelopes, set the lever to the rear position ; for everything else, set the lever to the forward position .

**6. Print Cartridge (black)****7. Print Cartridge (cyan)****8. Print Cartridge (magenta)****9. Print Cartridge (yellow)****10. Ink Collector Unit****11. Right Front Cover**

During normal usage, keep this cover closed. Open this cover only when you need to install or replace an ink cartridge or the ink collector unit.

**12. Paper Feed Wheel**

Use to wind out paper jammed around the guide board.

**13. Left Cover**

Normally, keep this cover closed. Open this cover when you need to turn the paper feed wheel.

---

## Machine Rear

---

This is a rear view of the printer.

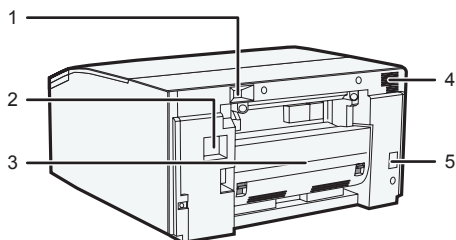

BUG104S

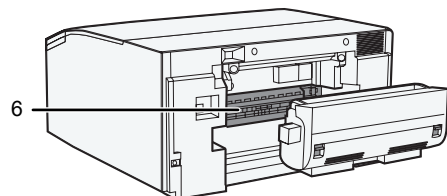

BUG105S

**1. USB slot**

Connect the USB cable from the computer here.

**2. Ethernet port**

Use a network interface cable to connect the printer to a network.

**3. Duplex Unit**

Turns the paper over when performing duplex printing.

**4. Vent**

Air is vented here to prevent the inside of the printer from getting too warm. Do not lean anything against the vent or block it in any way. If the inside of the printer gets too warm, a breakdown could occur.

**5. Power inlet**

Plug the power cord.

Plug one end of the power cord into the printer's power inlet and the other end into a wall outlet.

Connect the grounding wire attached to the power plug directly to a grounding terminal.

**6. Guide board**

To remove paper that has jammed inside the printer, open the guide board by removing the duplex unit.

---

## Control Panel

---

The illustrations in this manual show the **-22, -27** model. The **-17** model may differ slightly from the illustrated model.

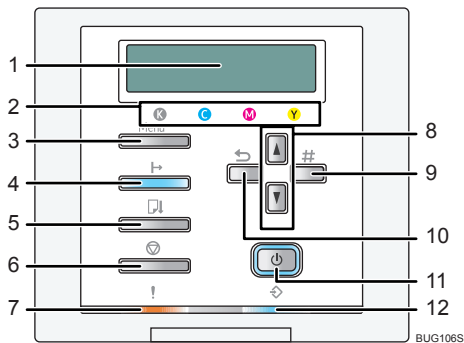

**1. Display**

Displays current printer status and error messages.

**2. Cartridge replacement indicator**

Each color corresponds to a print cartridge. From the left, the colors show the status of the black (K), cyan (C), magenta (M), and yellow (Y) cartridges.

**3. [Menu] key**

Press this key to make and check the current printer settings.



#### 4. [Online] key

Indicates whether the printer is online or offline. Press this to switch between online and offline.

When the lamp is lit, the printer is online, enabling data reception from the host computer.

When the lamp is unlit, the printer is offline, disabling data reception from the host computer.

Press to return to the ready condition.

#### 5. [Form Feed] key

When the printer is offline, press this to print all data left in the printer's input buffer.

You can use this to force the printer to print data received in the online status when the paper size or type does not match the actually set size or type.

If a message prompting you to remove the jammed paper by pressing the [Form Feed] key appears, press this key.

#### 6. [Job Reset] key

When the printer is online, press this key to cancel an ongoing print job.

#### 7. Alert indicator

Lights up whenever a printer error occurs. A red light indicates an error has occurred that makes printing impossible; blinks red to indicate a possible error during printing.

If the red light is on, follow the instructions that appear on the display.

#### 8. [▲][▼] keys

Use these keys to increase or decrease values on the display when making settings.

Keep the key pressed to quicken scrolling, and increase or decrease values on the display in units of 10.

To apply this function: under [Maintenance], set [Key Repeat] to [On].

When the printer is online and the "Ready" message is displayed on the control panel, press the [▼] key to clean the cyan, magenta, yellow, and black print heads ([-17] only).

#### 9. [#Enter] key

Press this key to execute menu items selected on the display.

#### 10. [Escape] key

Press this key to return to the previous condition on the display.

#### 11. [Power] key

- Press to turn the power on and off.
- To turn the power on, press and hold down the [Power] key for one second until it lights.
- After the power is turned on, the [Power] key will flash until the printer is ready for printing, at which point the key will stop flashing and remain lit.
- When the power is turned off, the key will blink slowly until the printer has completely shut down at which point the key will be dark.
- ⏻ means "standby". To avoid any power consumption, disconnect the power plug from the wall outlet.

#### 12. Data In indicator

Blinks when the printer is receiving data from a computer or when the printer is carrying out maintenance. The Data In indicator is lit if there is data to be printed.

### Reference

- For details about the Key Repeat, see p.159 "Performing Maintenance using the Control Panel (Maintenance Menu)".

# 1

## Adjusting the Angle of the Control Panel

You can adjust the angle of the control panel for easier usage.

Use the following procedure to adjust the angle of the control panel.

### Raising the Control Panel

1. Raise the control panel by carefully pulling it upward and forward.



BPR189S

2. Insert the stopper on the back of the control panel into one of the grooves beneath.

### Lowering the Control Panel

1. Carefully pull the control panel slightly forward (①).

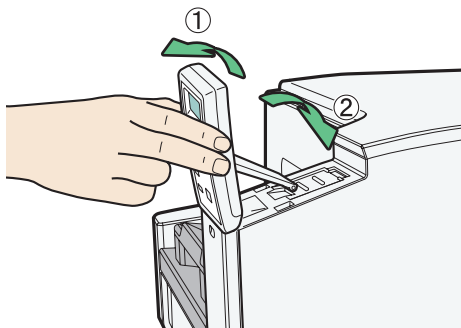

BPR190S

2. Lower the control panel (②).

### Note

- You can set the tilt to one of three angles.

# Making Printer Settings Using the Control Panel

This section explains how to change the default settings of the printer and provides information about the parameters included in each menu. For details about procedures and settings, see the information under in [Reference](#).

1

## Counter

| Menu         |
|--------------|
| Show Counter |
| Print        |

## Paper Input

| Menu            |
|-----------------|
| Tray Paper Size |
| Paper Type      |
| Aut.Tray Select |
| Tray Priority   |

## List/Test Print

| Menu             |
|------------------|
| Config. Page     |
| Color Demo Page  |
| Error Log        |
| PCL Config. Page |

## Maintenance

| Menu          |
|---------------|
| Nozzle Check  |
| Head-cleaning |
| Head-flushing |

| Menu             |
|------------------|
| Head Position    |
| Adj. Paper Feed  |
| Registration     |
| Date/Time        |
| Key Repeat       |
| Dry-delay (Exit) |
| Dry-delay (Dup)  |
| Paper Feed Test  |
| De-condensation  |

## System

| Menu            |
|-----------------|
| Prt. Err Report |
| Auto Continue   |
| Sub Paper Size  |
| Energy Saver    |
| Notify by Email |
| Memory Usage    |
| Unit of Measure |
| Page Size       |
| Paper Type      |
| Preprinted Ppr  |
| Copies          |
| Duplex          |
| Blank Pg. Print |

| Menu            |
|-----------------|
| Tray Switching  |
| Uni-direct.Prt. |
| Density         |
| Color Mode      |
| Recycl.Ppr.Mode |
| Env.Slctr.Alert |
| Pg Recov. Error |
| Ink C.U. Space  |

**Host Interface**

| Menu          |
|---------------|
| I/O Timeout   |
| Network Setup |
| USB Setting   |

**PCL Menu**

| Menu          |
|---------------|
| Orientation   |
| Form Lines    |
| Font Source   |
| Font Number   |
| Point Size    |
| Font Pitch    |
| Symbol Set    |
| Courier Font  |
| Ext. A4 Width |

| Menu            |
|-----------------|
| Append CR to LF |
| Resolution      |
| Black Printing  |

## Language

| Menu                        |
|-----------------------------|
| Japanese                    |
| English                     |
| German                      |
| French                      |
| Italian                     |
| Dutch                       |
| Danish                      |
| Swedish                     |
| Norwegian                   |
| Spanish                     |
| Finnish                     |
| Portuguese                  |
| Czech ([-22, -27] only)     |
| Polish ([-22, -27] only)    |
| Hungarian ([-22, -27] only) |

### Reference

- p.157 "Checking the Number of Printed Pages using the Control Panel (Counter Menu)"
- p.94 "Specifying the Paper Settings using the Printer's Control Panel (Paper Input Menu)"
- p.65 "Checking the Printer Status and Settings using the Printer's Control Panel (List/Test Print Menu)"
- p.159 "Performing Maintenance using the Control Panel (Maintenance Menu)"

- p.178 "Specifying System Settings using the Control Panel (System Menu)"
- p.73 "Specifying the Interface and Network Settings using the Printer's Control Panel (Host Interface Menu)"
- p.184 "Specifying PCL Settings using the Control Panel (PCL Menu)"
- p.187 "Selecting the Control Panel Language"
- p.189 "Restricting Printer Functions"

# Options

This section explains the names and functions of the various available options.

1

## Paper Feed Unit TK1110

This optional tray can hold 500 sheets.

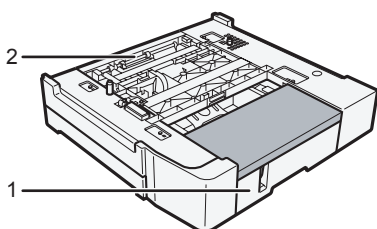

BUG221S

### 1. Tray 2/Tray 3

Load paper here.

If you want to print on paper larger than A4 or letter size, pull the tray extension out.

### 2. Rear Unit

The rear unit should be removed when a paper jam occurs in the paper feed unit.

Up to two paper feed units can be attached.

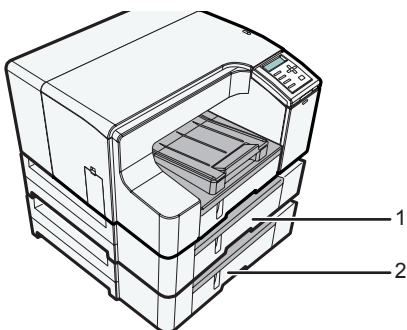

BUG232S

### 1. Tray 2

When two paper feed units are attached, the upper tray is referred to as tray 2.

### 2. Tray 3

When two paper feed units are attached, the lower tray is referred to as tray 3.



## Multi Bypass Tray BY1000

Use this tray to feed in sheets manually.

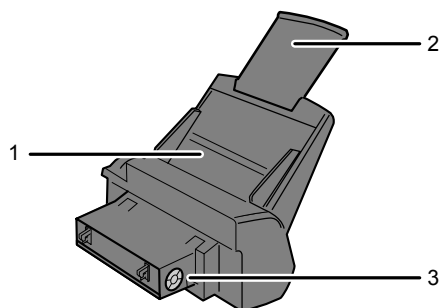

BPR107S

### 1. Bypass tray

Load paper here.

### 2. Bypass tray extension

Pull this out according to the paper size.

### 3. Wheel

Use this to wind out paper that became jammed after being fed in from the bypass tray.

## Detaching and Reattaching the Multi Bypass Tray

To clear a paper jam, you might have to detach the bypass tray.

This section explains how to detach and reattach the bypass tray.

1. Remove any paper in the bypass tray.
2. Push the bypass tray extension in.
3. Detach the bypass tray.

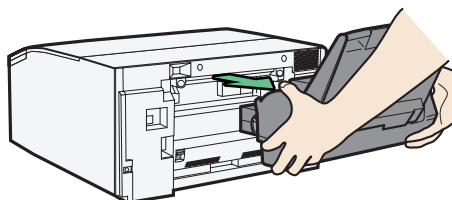

BUG106S

#### 4. Reattach the bypass tray.

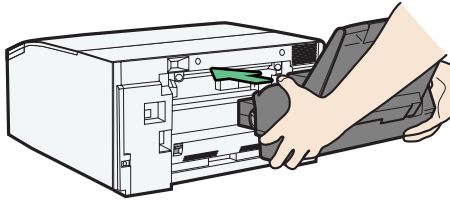

BUG109S

#### 5. Pull the bypass tray extension out.

#### 6. Load paper in the bypass tray.

#### ↓ Note

- After attaching the paper feed unit, you must register where to start printing on paper loaded in the paper feed unit.
- When you attach the bypass tray, take care not to trap the USB cable.

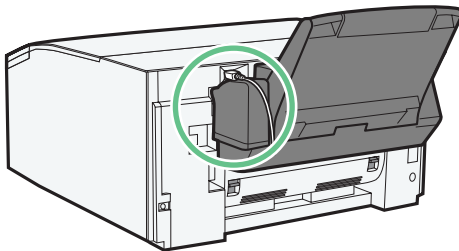

BUG198S

- When you detach and reattach the bypass tray, switch the printer off.

#### 📖 Reference

- For details about registering where to start printing on paper loaded in the paper feed unit, see p.170 "Registration".

---

# Recommended Functions

This section lists useful and recommended functions.

## **Automatically selecting the tray for printing**

See p.94 "Specifying the Paper Settings using the Printer's Control Panel (Paper Input Menu)".

## **Copy-guard of printed documents for preventing information leaks**

See p.101 "Printing".

## **Notifying the printer status by e-mail on an occasion such as if the printer runs out of paper or paper is jammed**

See p.117 "Notifying the Printer Status by E-mail".



# 2. Preparing for Printing

---

## Setting Up the Hardware

This section explains how to install the printer.

---

### Checking the Computer and Installation Area

---

The printer's location should be carefully chosen because environmental conditions greatly affect its performance.

#### The area where the printer is to be placed

---

**★ Important**

- To avoid malfunctions, position the machine away from the following:
  - direct sunlight
  - flow of air from air conditioners or heaters
  - radios, televisions, or other electronic devices
  - areas of high/low temperature and high/low moisture
  - humidifying appliances
  - oil stoves and ammonia-emitting appliances (such as diazo copiers)

Choose a flat, stable area to install the machine.

- The surface should be level within two degrees, left to right and front to back.
- To prevent condensation, install the machine in an area where temperature and humidity conditions do not exceed those indicated in the diagram below.
- The machine may cease to print if these limitations are exceeded.

**-22, -27**

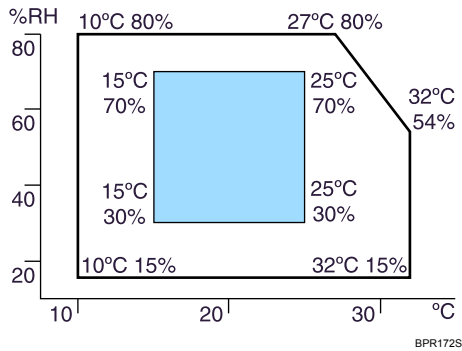

**-17**

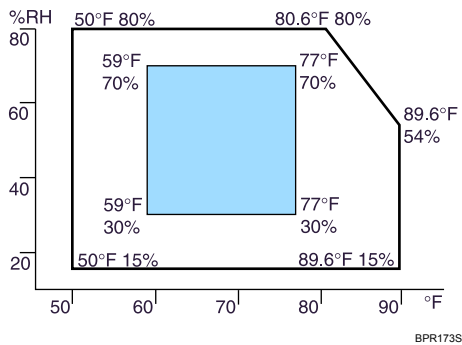

- White area: Permissible Range
- Blue area: Recommended Range
- The diagram below shows the ideal clearance for loading paper, replacing print cartridges, and removing jammed paper

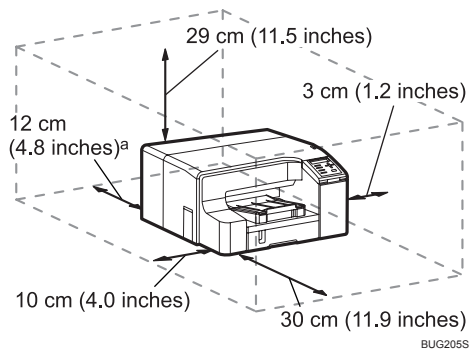

a. If you attach the bypass tray (option), provide additional clearance of 29 cm (11.5 inches).

## Check the power source

### **WARNING**

- Keep the machine away from humidity and dust. Otherwise a fire or an electric shock might occur.
- Place the machine on a strong and level surface. Otherwise, the machine might fall and cause personal injury.
- If you use the machine in a confined space, confirm that there is a continuous flow of air.
- Only connect the machine to the power source described on this sheet.
- Avoid multi-wiring.
- Connect the power cord directly into a wall outlet and never use an extension cord.
- Do not damage, break or make any modifications to the power cord. Do not place heavy objects on it. Do not pull it hard nor bend it more than necessary. These actions could cause an electric shock or fire.
- Do not plug or unplug the power cord with your hands wet. Otherwise, an electric shock might occur.
- Make sure the wall outlet is near the machine and freely accessible so that in event of an emergency it can be unplugged easily.

The power requirements of this machine are as follows:

- 100-120 V: 50/60 Hz 1.2 A
- 220-240 V: 50/60 Hz 0.6 A

## Checking the Computer to be Connected

To use this printer, computers must meet the following specifications:

- PC/AT-compatible computer with USB or network interface
- Operating system: Windows 2000/ XP/Vista, Windows Server 2003/2008
- 80-100MB or more available hard disk space

### **Note**

- To operate this printer, your computer must have at least the amount of memory necessary to run its operating system.

## Checking the Supplied Items and Unpacking the Printer

### **CAUTION**

- The machine weighs around 15.5 kg (34.2 lb) (29.9 kg (65.9 lb) with options installed).

- Careless handling and over exertion when lifting can result in breakage and/or injury.

**★ Important**

- Do not turn the machine on until you have read how to do so.

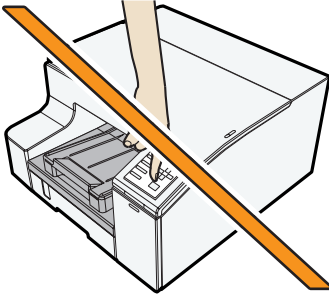

BUG1115

2

Open the box and take out all supplied items. Check that all the following items are present:

- Power Cord
- Starter cartridge - Cyan
- Starter cartridge - Magenta
- Starter cartridge - Yellow
- Starter cartridge - Black
- Quick Installation Guide
- Safety information
- CD-ROM; User Guide is included on this.

**1. Take off the protective covering.**

**2. Remove the plastic bag.**

**3. Lift the printer and move it to the place where you want to install it.**

Grip the indented area at the base of the printer's sides, as shown. Lift and carry the printer slowly and carefully.

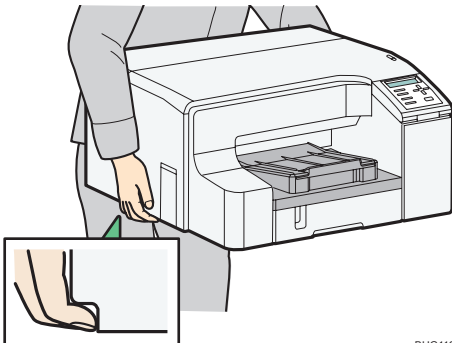

BUG1125



#### 4. Remove the orange tape from the printer body.

##### ↓ Note

- We recommend you keep the box, so you can use it again when relocating the printer.
- Remove all the orange tape, except the tape around the power cord.
- USB and LAN cables are not supplied.

## Attaching the Options

### Attaching the Paper Feed Unit TK1110

#### ⚠ CAUTION

- The machine weighs around 15.5 kg (34.2 lb) (29.9 kg (65.9 lb) with options installed).
- Careless handling and over exertion when lifting can result in breakage and/or injury.

1. Make sure the printer's power cord is unplugged.
2. Take the paper feed unit out of its box.
3. Position the paper feed unit close to the printer.
4. Remove the orange tape from the paper feed unit.
5. Align the connecting parts of the printer and paper feed unit, and then lower the printer onto the paper feed unit.

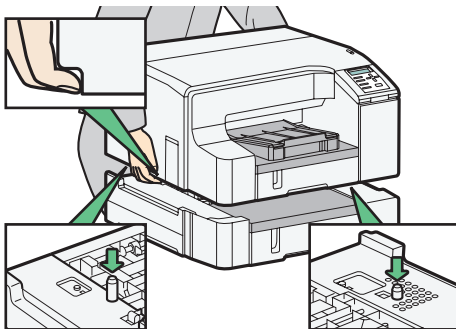

BUG227S

After attaching the paper feed unit, you must register where to start printing on paper loaded in the paper feed unit.

##### ↓ Note

- Align the paper feed unit and printer using their corners.
- When the printer is placed on top of the paper feed unit, installation is complete.
- Do not tilt the printer.

- Be careful not to trap your fingers.
- Up to two paper feed units can be attached.
- To install two paper feed units, put the upper paper feed unit (tray 2) on the lower paper feed tray (tray 3) first, and then lower the printer onto the upper paper feed unit (tray 2).

**Reference**

- For details about registering where to start printing on paper loaded in the paper feed unit, see p. 170 "Registration".

2

---

### Attaching the Multi Bypass Tray BY1000

---

1. Make sure the printer's power cord is unplugged.
2. Take the bypass tray out of its box.
3. Remove the orange tape from the bypass tray.
4. Fully insert the bypass tray.

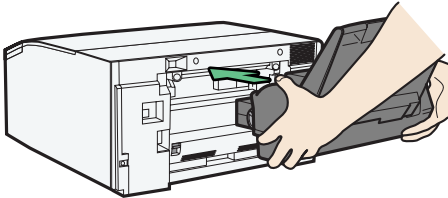

BUG109S

5. When using the bypass tray, pull out its extension and adjust the side guides according to the size of the loaded paper.

After attaching the paper feed unit, you must register where to start printing on paper loaded in the paper feed unit.

**Reference**

- For details about registering where to start printing on paper loaded in the paper feed unit, see p. 170 "Registration".

---

### Installing the Print Cartridges

---

**CAUTION**

- If ink comes into contact with your eyes, rinse immediately in running water. For other symptoms, consult a doctor.

- If ink is ingested, induce vomiting by drinking a strong saline solution. Consult a doctor immediately.
- If your skin comes into contact with ink, wash the affected area thoroughly with soap and water.
- Keep the ink or ink container out of reach of children.

**★ Important**

- Do not turn the machine on until you have read how to do so.

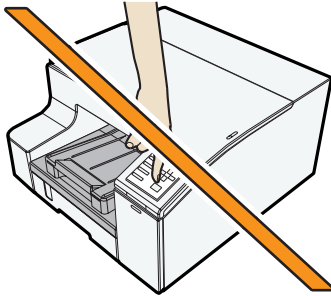

BUG111S

- Be sure to install the unused print cartridge that is supplied. Installing any other cartridge could result in incomplete ink filling and malfunction.

**1. Remove the packaging from the print cartridges.**

Do not touch the ink supply ports or silicon substrates of print cartridges.

- 2. While pressing the recessed area (①) of the right front cover, open the cover (②).**

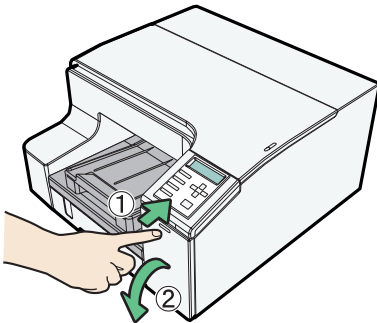

BUG113S

**3. Check the orientation of each cartridge, and then install them gently.**

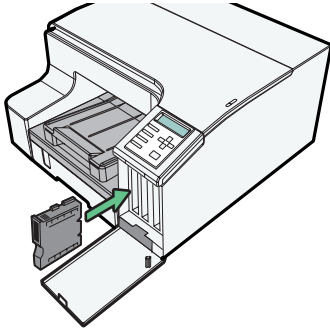

BUG114S

Install in the following order from the left: black, cyan, magenta, and yellow.

- 4. Push in each cartridge.**
- 5. Repeat steps 3 to 4 for all four cartridges.**
- 6. Close the right front cover.**

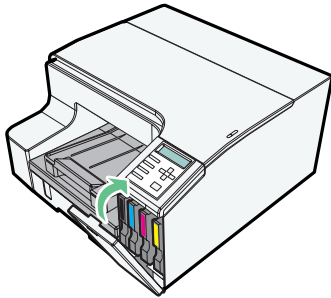

BUG115S

---

## Plugging in the Power Cord and Turning the Power On

---

Before connecting the printer to a computer, connect the printer's power cord and switch the printer on.

**⚠ WARNING**

- Only connect the machine to the power source described on this sheet.
- Avoid multi-wiring.
- Connect the power cord directly into a wall outlet and never use an extension cord.
- Do not damage, break or make any modifications to the power cord. Do not place heavy objects on it. Do not pull it hard nor bend it more than necessary. These actions could cause an electric shock or fire.

- Do not plug or unplug the power cord with your hands wet. Otherwise, an electric shock might occur.

**★ Important**

- Do not handle the machine while the cartridge is being filled. Ink filling begins when the machine's power is switched on. Until the "Loading Ink..." message disappears from the control panel.
1. Remove the orange tape from around the power cord.
  2. Plug the power cord fully into the printer.

2

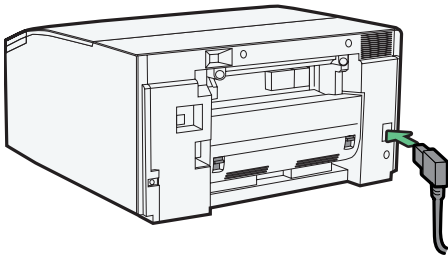

BUG116S

3. Plug the power cord fully into the wall outlet.

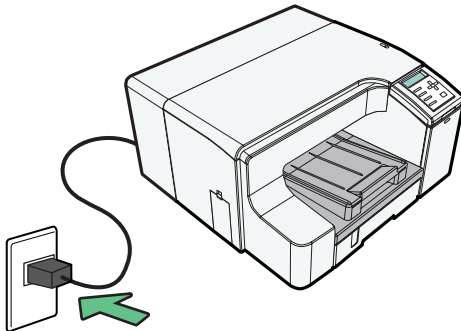

BUG117S

The surface should be level within two degrees.

Make sure the power cord is not trapped under the printer.

**4. Press the [Power] key.**

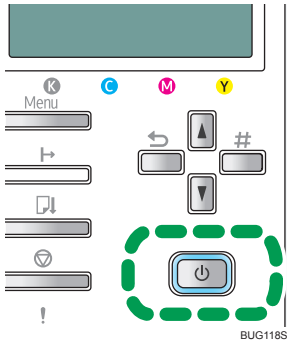

The printer starts feeding ink into its print-heads (taking approximately 10 minutes).

Make sure the "Ready" message is displayed on the control panel.

Do not switch off the power of the machine during this period. Make sure the plug is not removed from the wall outlet.

You might hear a clicking sound while the print heads are filling. This is not a malfunction. It will stop after a while.

---

## Loading Paper

---

Load paper into the paper tray.

Normally, load paper into tray 1.

**Note**

- Load paper with the paper grain parallel to the feed direction.

---

### Loading Paper into Tray 1

---

Follow the procedure below to load paper into tray 1.

A4/Letter size paper is loaded here.

**Important**

- Load A4/Letter size paper in  orientation.

1. Hold the Tray 1 grip, pull the tray halfway out, lift it slightly (①), and then pull it out further (②).

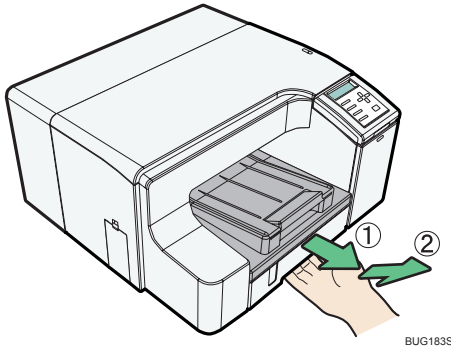

Pull tray 1 completely out. Take care not to drop it.

2. While squeezing the catch on the paper guide, slide the guide so it is positioned according to the paper size.

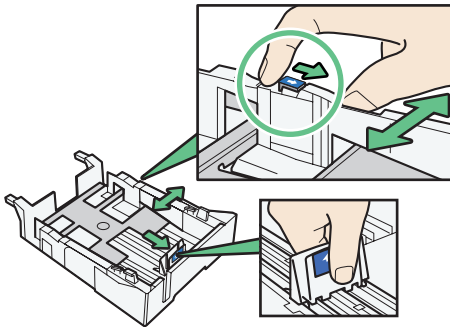

Beforehand, make sure to squeeze the front end paper guide, and then expand the guide.

3. Load paper with the print side face down but not over the limit mark.

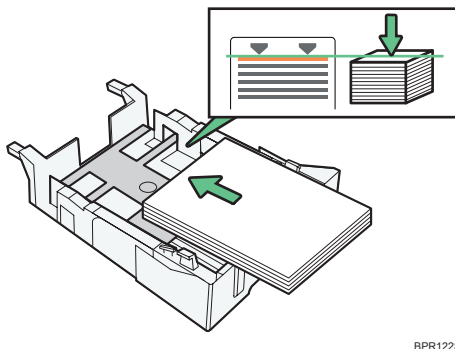

2

4. Squeeze the front end paper guide, and then slide it to meet the edge of the paper.

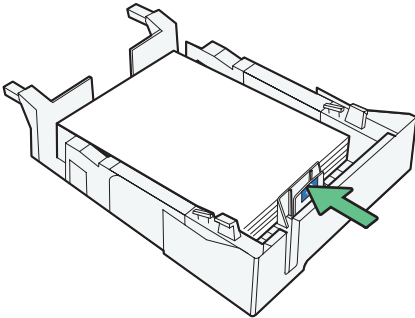

BPR123S

5. Push tray 1 gently in until it stops.

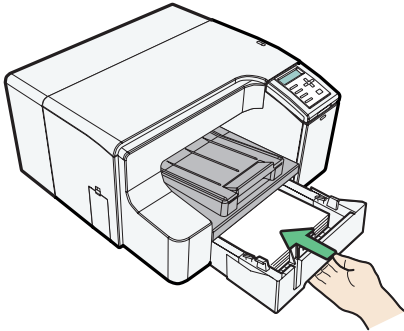

BUG125S

### Loading Paper Larger than A4/Letter (Tray 1)

---

Follow the procedure below to use the paper tray extension for paper larger than A4/Letter size, such as Legal size paper.

Legal size paper is loaded here.

**★ Important**

- Load Legal size paper in  orientation.



1. Hold the Tray 1 grip, pull the tray halfway out, lift it slightly (①), and then pull it out further (②).

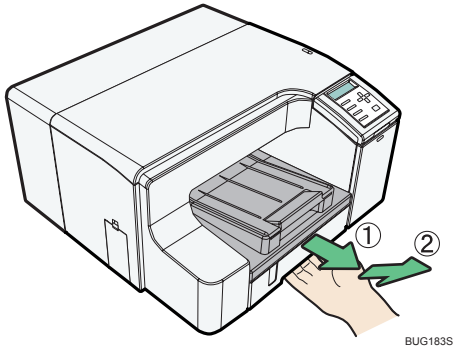

Pull tray 1 completely out. Take care not to drop it.

2. Slide the tabs on both sides of the tray's interior to the unlocked position.

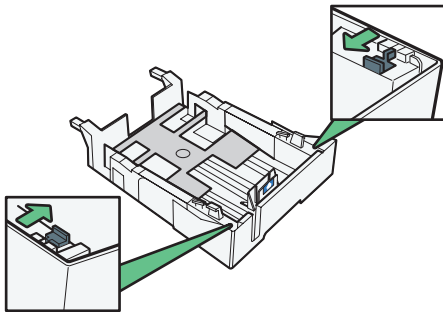

3. Pull out the paper tray extension.

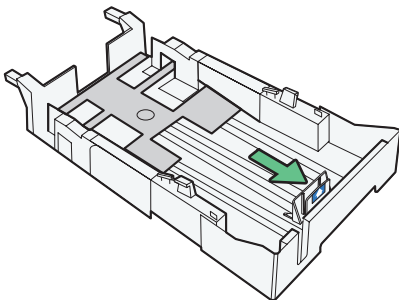

2

4. Slide the tabs back into place to lock the paper tray extension into position.

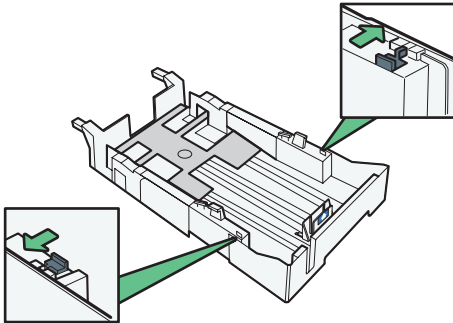

BPR168S

5. While squeezing the catch on the paper guide, slide the guide so it is positioned according to the paper size.

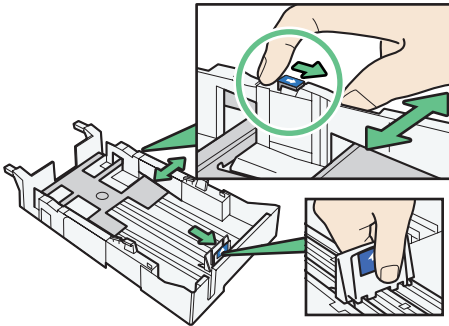

BPR169S

Do not use the paper tray extension for A4 (Letter) size paper or smaller paper. Use it only for long paper.

6. Load paper with the print side face down but not over the limit mark.

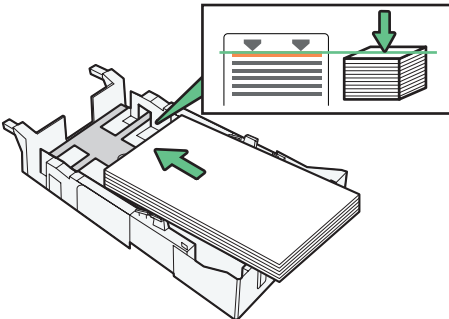

BPR170S

7. Squeeze the front end paper guide, and then slide it to meet the edge of the paper.

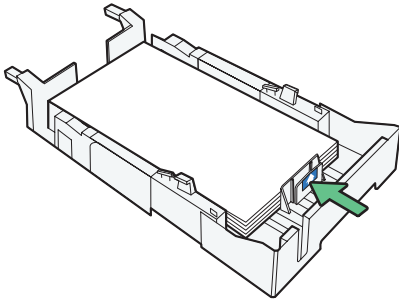

BPR171S

8. Push tray 1 gently in until it stops.

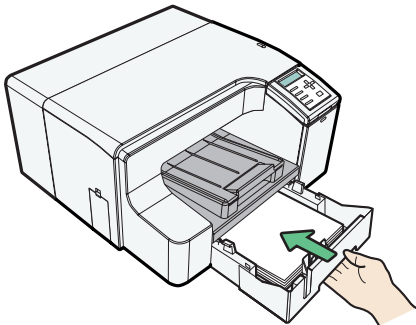

BUG174S

9. Pull out the output ramp extension.

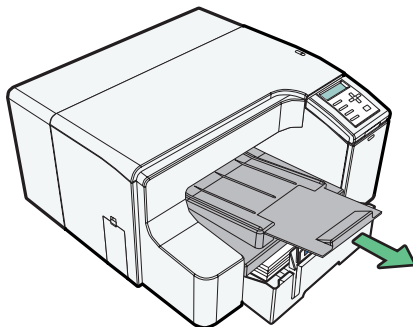

BUG175S

## Loading Paper into Tray 2/Tray 3

Follow the procedure below to load paper into tray 2/tray 3.

You can load plain paper and inkjet plain paper in tray 2/tray 3.

A4/Letter size paper is loaded here.

**★ Important**

- Load A4/Letter paper in  orientation.

1. Hold the Tray 2/Tray 3 grip, pull the tray halfway out, lift it slightly (①), and then pull it out further (②).

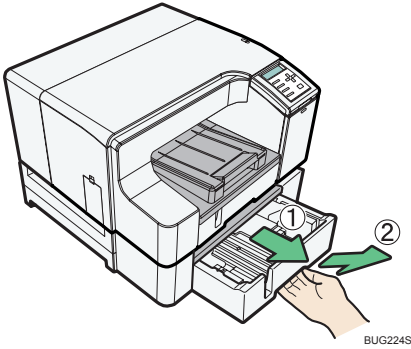

Pull tray 2/tray 3 completely out. Take care not to drop it.

2. While squeezing the catch on the paper guide, slide the guide so it is positioned according to the paper size.

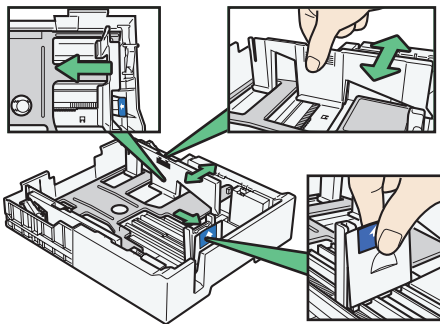

Beforehand, make sure to squeeze the front end paper guide, and then expand the guide.

3. Load paper with the print side face down but not over the limit mark.

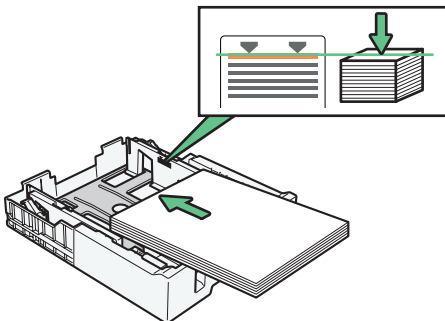

4. Push tray 2/tray 3 gently in until it stops.

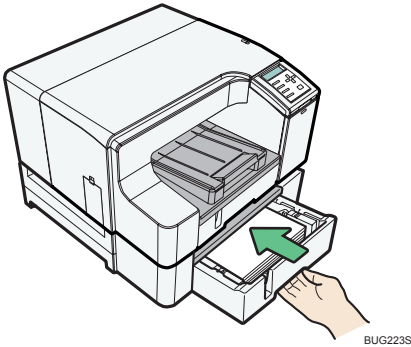

### Loading Paper Larger than A4/Letter (Tray 2/Tray 3)

Follow the procedure below to use the paper tray extension for paper larger than A4/Letter size, such as Legal size paper.

1. Hold the Tray 2/Tray 3 grip, pull the tray halfway out, lift it slightly (①), and then pull it out further (②).

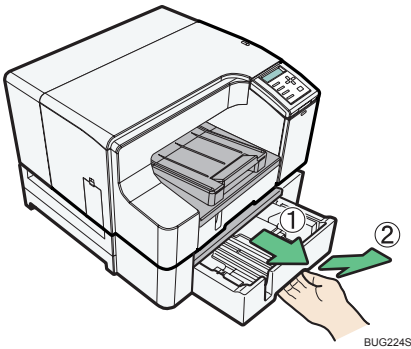

Pull tray 2/tray 3 completely out. Take care not to drop it.

2. Slide the tabs on both sides of the tray's interior to the unlocked position.

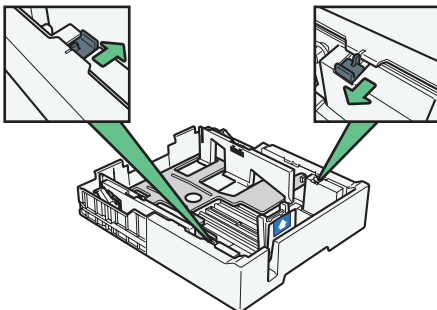

**3. Pull out the paper tray extension.**

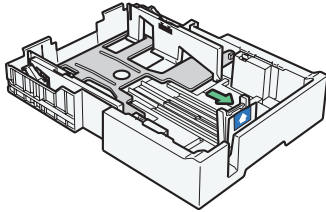

BUG236S

**4. Slide the tabs back into place to lock the paper tray extension into position.**

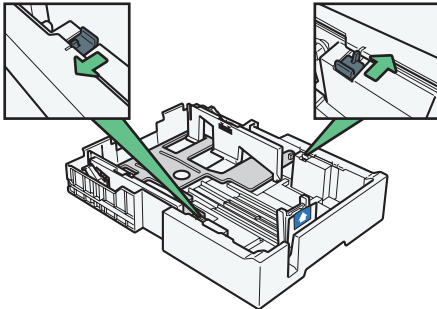

BUG237S

**5. While squeezing the catch on the paper guide, slide the guide so it is positioned according to the paper size.**

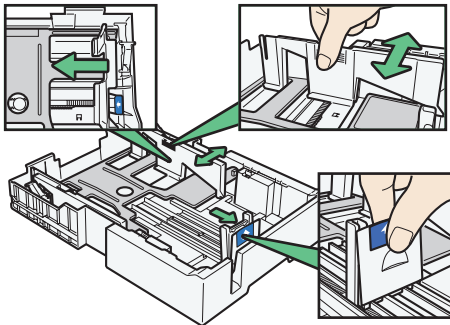

BUG238S

Do not use the paper tray extension for A4 (Letter) size paper or smaller paper. Use it only for long paper.

Beforehand, make sure to squeeze the front end paper guide, and then expand the guide.

6. Load paper with the print side face down but not over the limit mark.

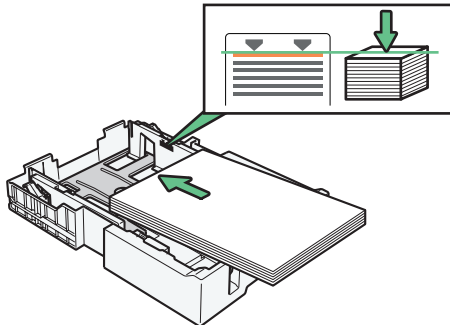

BUG239S

7. Push tray 2/tray 3 gently in until it stops.

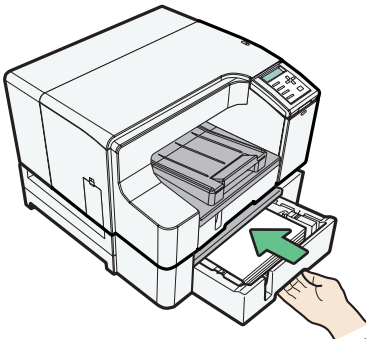

BUG223S

### Loading Paper into Bypass Tray (optional)

Follow the procedure below to load paper into bypass tray.

A4/Letter size paper is loaded here.

1. Pull the bypass tray extension out all the way.
2. Load paper in the bypass tray with the side to be printed on facing up.

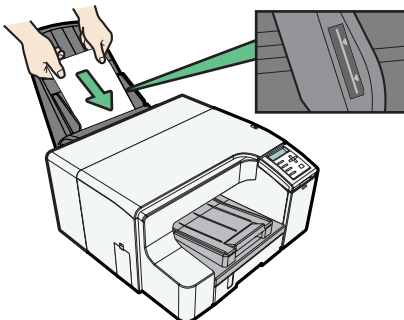

BUG126S

Before loading narrow paper, position the side paper guides according to the paper size.

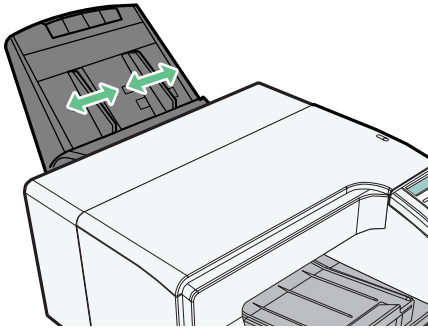

## Printing a Configuration Page

After setting up the hardware and before connecting the printer to a computer, make a test print by printing the configuration page.

Printing the configuration page as a test print primes the print heads and allows you to check that the printer is functional.

You can also use the configuration page to check the printer's configuration and system settings.

### ★ Important

- The configuration page is printed on A4 or Letter (8 1/2" × 11") size paper, so load them in the same paper tray.

1. Press the [Menu] key.

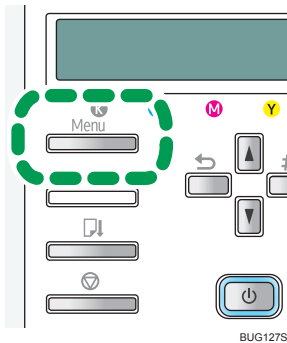

2. Press the [▲] or [▼] key to display [List/Test Print], and then press the [#Enter] key.

```
Menu:  
List/Test Print
```

3. Press the [▲] or [▼] key to display [Config. Page], and then press the [#Enter] key.

```
List/Test Print:  
Config. Page
```



The configuration page is printed.

The List/Test Print menu screen returns on completion of printing.

Check whether the print-head nozzles are clogged up or not by printing a nozzle check test pattern.

#### **4. Hold the [Power] key down until the printer shuts down.**

If you are connecting the printer to a computer via USB, proceed to p.56 "Connecting the Computer and Installing the Software (USB Connection)".

If you are connecting the printer to a network, proceed to p.60 "Connecting the Computer and Installing the Software (Network Connection)".

#### **Reference**

- For details about printing a nozzle check test pattern, see p.160 "Nozzle Check".
- For details about the items on the configuration page, see p.65 "Checking the Printer Status and Settings using the Printer's Control Panel (List/Test Print Menu)".

# Connecting the Computer and Installing the Software (USB Connection)

After setting up the hardware and making a test print, connect the printer to your computer. This section explains how to connect the printer to a computer using a USB cable, and how to install the software using "Quick Install".

### Reference

- For details about the connection method, see p.66 "Confirming the Connection Method".
- For details about the installing the printer driver only, see p.68 "Installing the PCL or RPCS Raster Printer Driver (USB)".

---

## Before Installing the Software (USB)

---

Before installing the software, connect the printer to your computer using a USB cable.

### Note

- Even if the computer that you are connecting the printer to via USB is networked, you can still connect the printer and computer according to the procedure explained in this section. For details about sharing the printer, see p.70 "Sharing the Printer".

## Connecting the Printer via USB

---

1. **Make sure the printer is off.**

Do not turn the printer on until you have read how to do so.

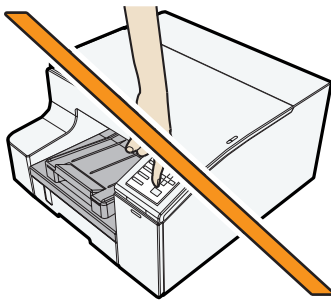

BUG111S

2. **Turn on the power of the computer, and start Windows.**

3. Remove the seal on the USB slot located on the rear of the printer, and then insert the USB cable's hexagonal (type B) plug firmly into the slot.

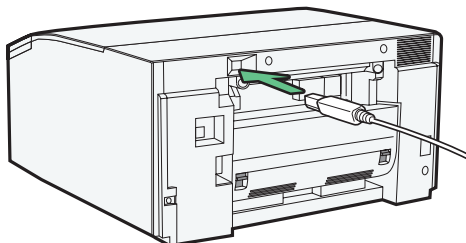

BUG128S

4. Insert the USB cable's rectangular (type A) plug firmly into the computer's USB slot.

**Note**

- Insert the USB cable's plug with the USB mark facing down.
- Make sure that the USB cable is fully inserted.
- Make sure the USB cable is connected properly, especially when the bypass tray is attached to the printer, because the tray makes connecting the cable difficult.

## Quick Install for USB

Follow the procedure below to install the printer driver and User Guide.

**Important**

- Do not turn the printer on until you have read how to do so.

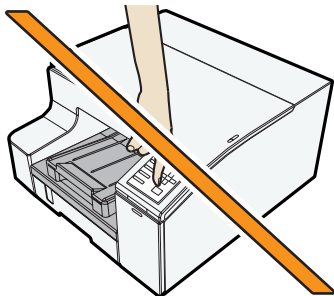

BUG111S

- Only administrators can perform this installation. Log on as a member of the Administrators group.

### Notes on the Installation (USB Connection)

If the message "Digital Signature Not Found" or the [Software Installation] , [Hardware Installation] or [Windows can't verify the publisher of this driver software] dialog box appears:

1. Click [Yes], [Continue Anyway] or [Install this driver software anyway] to continue the installation.

If the [Found New Hardware Wizard] dialog box appears:

1. Click [Install from a list or specific location (Advanced)], and then click [Next >].
2. Click [Include this location in the search], and then click [Browse].
3. Browse to "DRIVERS" on the CD-ROM, and then click [OK]. Select the folder appropriate for your operating system.

Be sure to clear the [Search remove media (floppy, CD-ROM...)] check box.

For details about the files stored on the CD-ROM labeled, see p.287 "Software on the CD-ROM".

#### 1. Start Windows, and insert the provided CD-ROM into the CD-ROM drive.

Quit all applications currently running.

When you start Windows, the "Add New Hardware Wizard" may appear. If this happens, click [Cancel]. Check again that the power is off.

#### 2. Select a language for the interface, and then click [OK].

#### 3. Click [Quick Install for USB].

#### 4. Read the entire license agreement carefully. If you accept its terms, click [I accept the agreement.], and then click [Next >].

#### 5. Check that the power of the printer is off, and then click [Next >].

#### 6. Check again that the power of the printer is off, and then click [Next >].

Check that the dialog box below appears.

If the [Software Installation] or [Windows can't verify the publisher of this driver software] dialog box appears, see "Notes on the Installation".

#### 7. Make sure that the computer and printer are properly connected, and then press the [Power] key.

Installation starts.

If the connection to the computer was not confirmed, make the port settings again after installation is complete.

If the message "Digital Signature Not Found" or the [Found New Hardware Wizard] or [Hardware Installation] dialog box appears, see "Notes on the Installation".

#### 8. Select whether or not to open the printer status monitor automatically, and then click [Next >].

**9. Check the installation result, and then click [Next >].**

Install User Guide.

**10. Click [Finish].**

The printer driver and User Guide are now installed.

If the message "Digital Signature Not Found" or the [Found New Hardware Wizard] or [Hardware Installation] dialog box appears, see "Notes on the Installation".

**↓ Note**

- After inserting the CD-ROM, the [Printer Drivers, Manuals, Utilities] dialog box appears. If it does not, double-click the CD-ROM drive icon under [My Computer] or [Explorer], and then double-click [Setup.exe].
- When installation is complete, the User Guide icon appears on your desktop.
- If a message prompting you to restart the computer appears, restart the computer.
- Confirm the printer driver is correctly installed by checking the printer's [Power] key is lit, and then performing a test print.

# Connecting the Computer and Installing the Software (Network Connection)

After setting up the hardware and making a test print, connect the printer to your computer. This section explains how to connect the printer to a computer via Ethernet cable, and how to use "Quick Install".

### Reference

- For details about the connection method, see p.66 "Confirming the Connection Method".
- For details about the installing the printer driver only, see p.76 "Installing the Drivers for Network Connection".

## Before Installing the Software (Network Connection)

Connect the printer and computer via Ethernet cable. Then, on the printer's control panel, specify the printer's network settings according to the network environment, and then install the software.

## Connecting the Printer via the Network

Be sure to install all necessary network equipment, such as hubs, etc. before connecting the Ethernet cable to the printer.

You can connect a 10BASE-T or 100BASE-TX cable to the printer.

### Important

- **Ethernet cables are not supplied with this printer. Select your cable according to the network environment.**
1. **Plug the Ethernet cable into the Ethernet port on the rear of the printer.**

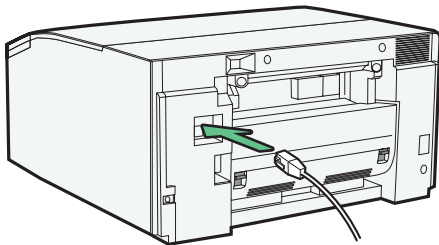

BUG124S

2. **Connect the other end of the cable to the printer's network, such as to a hub.**

Check the LEDs on the Ethernet port

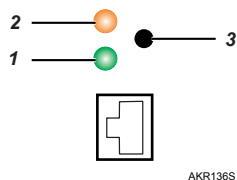

### 1. Indicator (green)

Remains green as long as the machine is properly connected to the network via 100 BASE-TX cable. Unlit if 10 BASE-T cable is connected.

### 2. Indicator (orange)

Lights whenever the printer is sending or receiving data via the network.

### 3. [Reset] key

Press this to initialize and reboot the network interface board.

2

## Specifying Settings on the Control Panel

Make the following network settings according to the network interface you are using.

If you have connected the printer to a network, make the required network environment settings.

The following table shows the control panel settings and their default values. These items appear in the [Network Setup] menu.

| Setting Name      | Value          |
|-------------------|----------------|
| 1.DHCP            | On             |
| 2.IP Address      | 0.0.0.0        |
| 3.Subnet Mask     | 0.0.0.0        |
| 4.Gateway Address | 0.0.0.0        |
| 5.Active Protocol | TCP/IP: Active |
| 6.Ethernet Speed  | Auto Select    |

The following example explains making settings for TCP/IP.

1. Press the [Power] key.

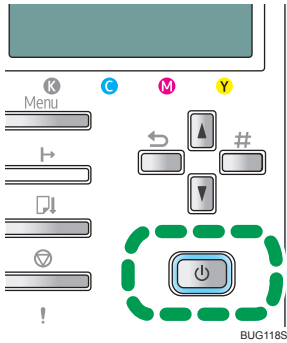

2. Press the [Menu] key.

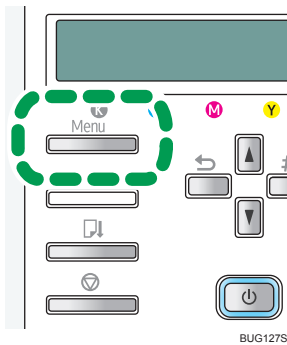

The Menu screen appears on the display.

3. Press the [▲] or [▼] key to display the [Host Interface] menu, and then press the [#Enter] key.



4. Press the [▲] or [▼] key to display [Network Setup], and then press the [#Enter] key.

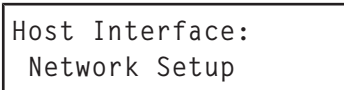

5. Press the [▲] or [▼] key to select [IP Address], and then press [#Enter] key.



The current IP address appears on the display.



6. Press the [▲] or [▼] key to enter the left most entry field of the IP address, and then press the [#Enter] key.

|                               |
|-------------------------------|
| IP Address :<br>■ . 0 . 0 . 0 |
|-------------------------------|

To get an IP address for the printer, contact your network administrator.

The value moves by 10 if the [▲] or [▼] key is kept pressed.

When the [#Enter] key is pressed, the cursor moves to the next field.

7. Press the [#Enter] key.

As the specified value is entered in each field, the cursor moves to the next field.

|                                 |
|---------------------------------|
| IP Address :<br>192 . ■ . 0 . 0 |
|---------------------------------|

8. Repeating the steps, specify values in all fields, and then press the [#Enter] key.  
To return to the previous field, press the [Escape] key.
9. Specify "Subnet Mask" and "Gateway Address" in the same way as when specifying the IP address.
10. After you have made all the settings, press the [Online] key.

The specified settings are set and the initial printer screen reappears.

You can print the configuration page to confirm the specified settings.

### Reference

- For details about how to print a configuration page, see p.54 "Printing a Configuration Page".

## Quick Install for Network

Follow the procedure below to install the printer driver, User Guide, and DeskTopBinder - SmartDeviceMonitor for Client.

### Important

- If the version of SmartDeviceMonitor for Client already installed in the computer is newer than that on the CD-ROM, you cannot use "Quick Install" to install the printer driver. Install the printer driver, and then create the port.
- Only administrators can perform this installation. Log on as a member of the Administrators group.

### Notes on the Installation (Network Connection)

If the message "Digital Signature Not Found" or the [Software Installation], [Hardware Installation] or [Windows can't verify the publisher of this driver software] dialog box appears:

1. Click [Yes], [Continue Anyway] or [Install this driver software anyway] to continue the installation.

**1. Start Windows, and insert the provided CD-ROM into the CD-ROM drive.**

Quit all other applications currently running.

**2. Select a language for the interface, and then click [OK].**

**3. Click [Quick Install for Network].**

**4. Read the entire license agreement carefully. If you accept its terms, click [I accept the agreement.], and then click [Next >].**

**5. The search for the network printer starts. If the selection dialog box appears, select the model of printer you want to use, and then click [Install].**

Installation starts.

If the [Software Installation], or [Windows can't verify the publisher of this driver software] dialog box appears, see "Notes on the Installation".

If the printer cannot be found and only "Printer Port" appears in the printer selection dialog box, either the printer's IP address has not been specified or the computer and printer are not on the same network segment. Before installing the software, check the printer's IP address and the network topology. Otherwise, select "Printer Port" in the dialog box, and then install the printer driver. If you do this, SmartDeviceMonitor for Client will not be simultaneously installed, so install it afterwards, and then configure the port.

If the message "Digital Signature Not Found" or [Hardware Installation] dialog box appears, see "Notes on the Installation".

**6. Click [Finish].**

The printer driver, User Guide, and DeskTopBinder - SmartDeviceMonitor for Client are now installed.



**Note**

- After inserting the CD-ROM, the [Printer Drivers, Manuals, Utilities] dialog box appears. If it does not, double-click the CD-ROM drive icon under [My Computer] or [Explorer], and then double-click [Setup.exe].
- When installation is complete, the User Guide icon appears on your desktop.
- If a message prompting you to restart the computer appears, restart the computer.
- Confirm the printer driver is correctly installed by checking the printer's [Power] key is lit, and then performing a test print.

# Checking the Printer Status and Settings using the Printer's Control Panel (List/Test Print Menu)

Using the List/Test Print menu on the control panel, you can print a configuration page to check whether the printer is working properly and to ascertain the printer's status and settings.

## Config. Page

You can print the current configuration of the printer.

## Color Demo Page

You can print color samples.

## Error Log

You can print error logs.

## PCL Config. Page

You can print the current PCL configuration.

### Reference

- For details about how to print a configuration page, see p.54 "Printing a Configuration Page".

---

## Interpreting the Configuration Page

---

### System Reference

Information such as the printer's version, attached options, printer language name, and remaining amount of ink are printed in this area.

Unlike [Counter] displayed on the machine's control panel, the "Total Counter" numbers include test patterns printed using "Maintenance", system configurations printed using "List/Test Print", and counter printouts made using "Counter".

### Paper Input

The specified [Tray Priority] setting and the specified settings in the Paper Input Menu, such as the size and type of paper loaded in each tray, are printed in this area.

### Host Interface, Interface Information

The specified settings in the Host Interface Menu are printed in this area.

### PCL Menu

Settings made on the [PCL Menu] are displayed.

## Confirming the Connection Method

This printer supports local and network connection.

Before installing the drivers, check how the printer is connected. Follow the driver installation procedure that is appropriate to the connection method.

2

### ★ Important

- **The printer driver for the 64-bit Windows is not included on the supplied CD-ROM. If your operating system is the 64-bit Windows, download the drivers from the supplier's Web site, and then store the files in an easily accessible folder.**

### Local Connection

If the printer is connected via USB, install the necessary software by inserting the supplied CD-ROM into your computer and then clicking [Quick Install for USB].

| Installation Key                              | Installed Software   |
|---|--|
| Quick Install for USB                         | <ul style="list-style-type: none"> <li>• Printer driver</li> <li>• User Guide</li> </ul> |
| PCL/RPCS Raster Printer Drivers               | Printer driver   |
| User Guide                                    | User Guide   |
| DeskTopBinder - SmartDeviceMonitor for Client | DeskTopBinder - SmartDeviceMonitor for Client  |

### Network Connection

If the printer is connected via the network, install the necessary software by inserting the supplied CD-ROM into your computer and then clicking [Quick Install for Network], [PCL/RPCS Raster Printer Drivers], and [DeskTopBinder - SmartDeviceMonitor for Client].

| Installation Key                              | Installed Software  |
|---|---|
| Quick Install for Network                     | <ul style="list-style-type: none"> <li>• Printer driver</li> <li>• User Guide</li> <li>• DeskTopBinder - SmartDeviceMonitor for Client</li> </ul> |
| PCL/RPCS Raster Printer Drivers               | Printer driver  |
| User Guide                                    | User Guide  |
| DeskTopBinder - SmartDeviceMonitor for Client | DeskTopBinder - SmartDeviceMonitor for Client   |

**Note**

- Once the settings are complete, the printer becomes ready for use.
- With a network connection, you can use the Windows printer port to send print jobs to the printer directly (peer-to-peer transfer) or use the printer as a network printer and send print jobs to the printer from a client computer via a print server.

**Reference**

- p.77 "Using the SmartDeviceMonitor for Client Port"
- p.81 "Using as the Windows Network Printer"
- p.82 "Installing the DeskTopBinder - SmartDeviceMonitor for Client "
- p.63 "Quick Install for Network"
- p.57 "Quick Install for USB"

## Installing the PCL or RPCS Raster Printer Driver (USB)

This section explains how to install only the printer driver when the printer is connected to a computer via USB.

2

If you installed the printer driver by performing Quick Install for USB, there is no need to install it again here.

### ★ Important

- Only administrators can perform this installation. Log on as a member of the Administrators group.
- Do not turn on the power at this point.

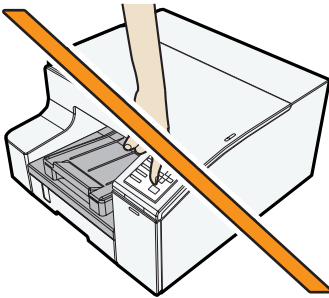

BUG111S

The following explanation uses Windows XP as an example. Procedures under other operating systems may differ.

Screens vary according to the operating environment.

### 1. Start Windows, and insert the provided CD-ROM into the CD-ROM drive.

Quit all other applications currently running.

When you start Windows, the Add New Hardware Wizard may appear. If this happens, click [Cancel]. Check again that the power is off, and then proceed to step 2.

After inserting the CD-ROM, the [Printer Drivers, Manuals, Utilities] dialog box appears. If it does not, double-click the CD-ROM drive icon under [My Computer] or [Explorer], and then double-click [SETUP.EXE].

If the [Printer Drivers, Manuals, Utilities] screen does not appear even when you double-click the SETUP.EXE icon, or if an error occurs during installation, access the CD-ROM drive from [My Computer] or [Explorer], double-click the RDISETUP.EXE icon in the [DRIVERS] folder, and then install the printer driver by following the instructions that appear on the screen.

### 2. Select a language for the interface, and then click [OK].

### 3. Click [PCL/RPCS Raster Printer Drivers].

4. Read the entire license agreement carefully. If you accept its terms, click [I accept the agreement.], and then click [Next >].
5. Click [Connected with USB cable], and then click [Next >].
6. Check again that the power of the printer is off, and then click [Next >].  
Check that the dialog box below appears.
7. Make sure that the computer and printer are properly connected, and then press the [Power] key.

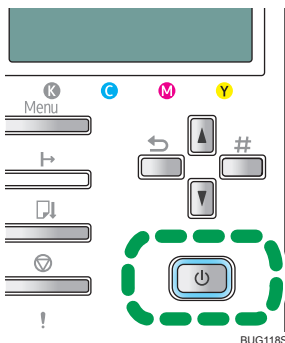

Installation starts.

8. Select whether or not to open the Status monitor automatically, and then click [Next >].
9. Check the installation result, and then click [Finish].

#### ↓ Note

- If the message "Digital Signature Not Found" or the [Found New Hardware Wizard] or [Hardware Installation] dialog box appears:
  - Click [Yes], [Continue Anyway] or [Install this driver software anyway] to continue the installation.
- If the message prompting you to restart the computer appears, restart the computer.
- Confirm the printer driver is correctly installed by checking that the [Power] key of the printer is lit and performing a test print.
- To perform a test print, open the printer properties dialog box, click [Print Test Page] on the [General] tab.
- To specify a USB port for sharing the printer on a server running Windows Firewall, add the port to Windows Firewall before using Status Monitor.
  1. On Windows Firewall dialog box, click the [Exception] tab, and then select the [File and Print Sharing] check box.
  2. Click [Add Port...], make sure [TCP] is selected, and then enter "55665" in [Port number].

#### 📖 Reference

- For details about installing User Guide only, see p.16 "Installing User Guide".
- For details about sharing the printer, see p.70 "Sharing the Printer".

- p.247 "If a Message Appears during Installation"
- p.209 "If Test Print Fails"

---

## Sharing the Printer

---

### 2

This section explains how to share the printer over a network by connecting it via USB to a computer acting as a print server.

### Setting Up a Server

---

Follow the procedure below to set up a print server so that the printer can be shared by users.

#### Important

- **Only administrators can make this setting. Log on as a member of the Administrators group.**

Configure a computer connected to the printer as the print server.

The print server is a computer used to manage the shared printer on the network.

1. On the [Start] menu, click [Control Panel].
2. Click [Network and Internet Connections].
3. Click [Network Connections].
4. Click [Local Area Connection] to highlight it, and then, in the [File] menu, click [Properties].
5. Select the [Client for Microsoft Networks] check box.
6. Click [OK].
7. Install the printer driver.
8. On the [Start] menu, click [Printers and Faxes].
9. Click the icon of the printer, and then click [Sharing...] on the [File] menu.
10. Click [Share this printer], and then enter a name in the [Share name] box.
11. Click [OK].

#### Note

- Configure a computer connected to the network, where the print server is connected, as a client computer.

#### Reference

- p.71 "Setting Up a Client Computer"



## Setting Up a Client Computer

Follow the procedure below to configure a computer as a client computer and connect it to the shared printer. Make this setting when installing the printer driver from the CD-ROM provided.

### ★ Important

- **Only administrators can make this setting. Log on as a member of the Administrators group.**

Configure a computer connected to the network where the print server is connected.

2

1. **Start Windows, and then insert the "Printer Drivers, Manuals, Utilities" CD-ROM into the CD-ROM drive.**

Quit all other applications currently running.

When starting Windows, a wizard for adding new hardware may open. If this happens, click [Cancel]. Check again that the power is off.

2. **Select a language for the interface, and then click [OK].**
3. **Click [PCL/RPCS Raster Printer Drivers].**
4. **Read the entire license agreement carefully. If you accept its terms, click [I accept the agreement.], and then click [Next >].**
5. **Click [Connected via LAN].**
6. **Click [Next >].**
7. **Click the plus mark next to a printer name.**
8. **Click [Port:< LPT1: >] under [Printer name:].**
9. **Click [Add].**
10. **Click [Network Printer].**
11. **Click [OK].**
12. **Select a shared printer.**
13. **Click [OK].**
14. **Check that [<\servername\sharedprintername>] appears after [Port:].**
15. **Click [Finish].**  
Installation starts.
16. **Select whether or not to open the Status monitor automatically.**
17. **Click [Next >].**
18. **Check the installation result, and then click [Finish].**

### ↓ Note

- When the CD-ROM is inserted, the [Printer Drivers, Manuals, Utilities] dialog box appears. If it does not, double-click the CD-ROM drive icon under [My Computer] or [Explorer], and then double-click [SETUP.EXE].

- If the message prompting you to restart the computer appears, restart the computer.

# Specifying the Interface and Network Settings using the Printer's Control Panel (Host Interface Menu)

In the Host Interface menu, you can make network settings and settings for the computer to printer USB connection (if used). Settings made using the Host Interface menu remain effective even if you turn the printer off.

To configure the printer's network settings, use "Network Setup" on the printer's control panel.

## I/O Timeout

Specify how long the printer waits for the currently-connected interface to respond. When the specified time elapses, the printer can receive data from another interface.

If you make the I/O Timeout period too short, timeout might occur while data transfer is in progress. If this happens, the print job will be interrupted by a new job from another interface.

- 10 seconds
- 15 seconds
- 20 seconds
- 25 seconds
- 60 seconds

Default: 15 seconds

## Network Setup

You can make network-related settings.

### DHCP

You can specify the DHCP.

- On
- Off

Default: On

### IP Address

You can specify the IP address.

When DHCP is set to on, the IP address cannot be changed. To change it, set DHCP to off.

Contact your network administrator for information about the network configuration.

Default: 0.0.0.0

### Subnet Mask

You can specify the subnet mask.

When DHCP is set to on, the subnet mask cannot be changed. To change it, set DHCP to off. Contact your network administrator for information about the network configuration.

Default: 0.0.0.0

### **Gateway Address**

You can specify the gateway address.

When DHCP is set to on, the gateway address cannot be changed. To change it, set DHCP to off. Contact your network administrator for information about the network configuration.

Default: 0.0.0.0

### **Active Protocol**

You can select the active protocol.

- TCP/IP

Default: Active

### **Ethernet Speed**

You can select the network speed to operate the printer.

- Auto Select
- 10Mbps Half D.
- 10Mbps Full D.
- 100Mbps Half D.
- 100Mbps Full D.

Default: Auto Select

### **USB Setting**

You can specify the settings related to communication when the computer and printer are connected via USB. Usually, you do not need to change these settings.

After changing this setting, turn the machine off and then back on.

#### **USB Speed**

- Full Speed
- Auto

Default: Auto

#### **Port Setting**

- On
- Off

Default: Off

## Changing the Host Interface Menu

This section gives an example of changing a setting in the Host Interface menu.

1. Press the [Menu] key.

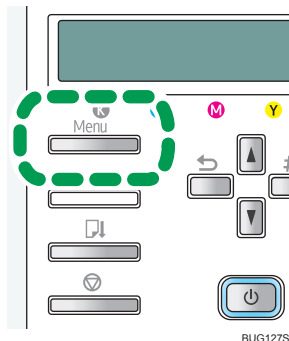

2. Press the [▲] or [▼] key to display [Host Interface], and then press the [#Enter] key.

```
Menu:
Host Interface
```

3. Press the [▲] or [▼] key to display [I/O Timeout], and then press the [#Enter] key.

```
Host Interface:
I/O Timeout
```

4. Press the [▲] or [▼] key to display [20 seconds], and then press the [#Enter] key.

```
I/O Timeout:
20 seconds
```

The [Host Interface] menu appears.

5. Press the [Online] key.

The initial screen appears.

# Installing the Drivers for Network Connection

This section explains how to install the printer driver for a network printer and configure it according to the printer port.

## Using this Printer as the Windows Printing Port

2

Network connections can be established through Ethernet.

Available ports are determined based on the combination of Windows operating system version and connection method used.

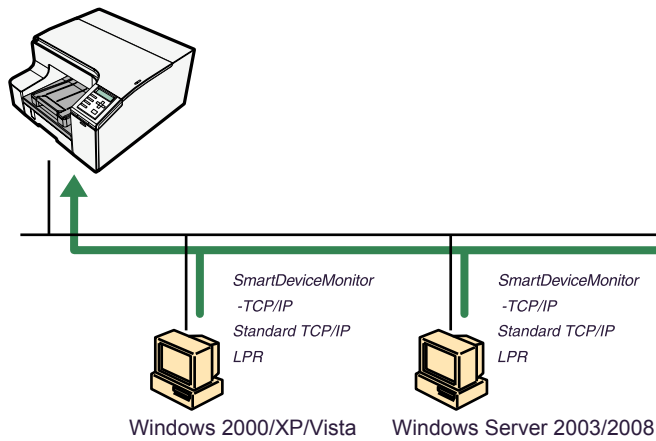

BUG130S

| Connection Method | Available Ports  |
|-------------------|--|
| Ethernet          | SmartDeviceMonitor for Client port<br>Standard TCP/IP port<br>LPR port |

## Using as a Network Printer

This printer can be used as the Windows network printer.

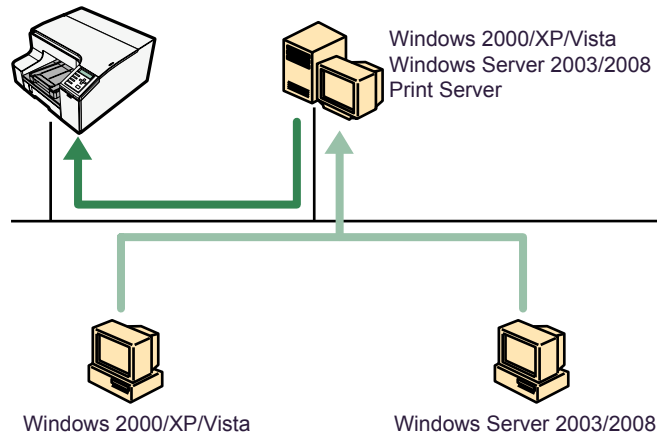

BUG131S

2

### Reference

- p.81 "Using as the Windows Network Printer"

## Installing the PCL or RPCS Raster Printer Driver (Network)

### Using the SmartDeviceMonitor for Client Port

This section explains how to install the printer driver (TCP/IP) and set up the SmartDeviceMonitor for Client port.

To use the SmartDeviceMonitor for Client port, you need to install the SmartDeviceMonitor for Client.

### ★ Important

- Only administrators can perform this installation. Log on as a member of the Administrators group.
1. Start Windows, and then insert the provided CD-ROM into the CD-ROM drive.  
Quit all applications currently running.
  2. Select an interface language, and then click [OK].
  3. Click [PCL/RPCS Raster Printer Drivers].  
The software license agreement appears in the [<License Agreement>] dialog box.
  4. Read the entire license agreement carefully. If you accept its terms, click [I accept the agreement.], and then click [Next >].
  5. Click [Connected via LAN], and then click [Next >].

**6. Double-click the printer name or click [+] to display the printer settings.**

The details shown in [Comment:], [Driver:], and [Port:] vary depending on the operating system, printer model, and port.

**7. Click [Port:], and then click [Add].**

**8. Click [SmartDeviceMonitor], and then click [OK].**

**9. Click [TCP/IP], and then click [Search].**

A list of printers using TCP/IP appears.

**10. Select the printer you want to use, and then click [OK].**

Only printers that respond to a broadcast from the computer appear. To use a printer not listed here, click [Specify Address], and then enter the IP address or host name of the printer.

**11. Check that the port of the selected printer is displayed in [Port:].**

**12. Select the [Default Printer] check box to configure the printer as default.**

**13. Click [Continue].**

Installation starts.

**14. Select whether or not to open the Status monitor automatically.**

**15. Click [Next >].**

**16. Click [Finish] in the installation completion dialog box.**

A message about restarting the computer may appear. Restart the computer to complete installation.

**Note**

- If the message "Digital Signature Not Found" or the [Software Installation], [Hardware Installation] or [Windows can't verify the publisher of this driver software] dialog box appears:
  - Click [Yes], [Continue Anyway] or [Install this driver software anyway] to continue the installation.
- To change the machine's settings while the machine is in use, uninstall the SmartDeviceMonitor for Client Port being used, change the machine's network settings on the control panel or using a Web browser, and then install the printer driver.

**Reference**

- A message appears if there is a newer version of the printer driver already installed. If there is, you cannot install the printer driver using Auto Run. If you still want to install the printer driver, use [Add Printer]. See p.247 "If a Message Appears during Installation".

## Using the Standard TCP/IP Port

---

This section explains how to install the printer driver (TCP/IP) and set up the Standard TCP/IP Port.



**★ Important**

- **Only administrators can perform this installation. Log on as a member of the Administrators group.**
- 1. Start Windows, and then insert the provided CD-ROM into the CD-ROM drive.**

Quit all applications currently running.
- 2. Select an interface language, and then click [OK].**
- 3. Click [PCL/RPCS Raster Printer Drivers].**

The software license agreement appears in the [<License Agreement>] dialog box.
- 4. Read the entire license agreement carefully. If you accept its terms, click [I accept the agreement.], and then click [Next >].**
- 5. Click [Connected via LAN].**
- 6. Double-click the printer name or click [+] to display the printer settings.**

The details shown in [Comment:], [Driver:], and [Port:] vary depending on the operating system, printer model, and port.
- 7. Click [Port:], and then click [Add].**
- 8. Click [Standard TCP/IP], and then click [OK].**

Configure the Standard TCP/IP port settings, and then see Windows Help if [Standard TCP/IP Port] does not appear.
- 9. Click [Next >] in the [Add Standard TCP/IP Printer Port Wizard] dialog box.**
- 10. Enter the printer name or IP address in the [Printer Name or IP Address] box.**

The [Port Name] text box automatically obtains a port name. Change this name if necessary.  
When screen for Device selection appears, select "RICOH Network Printer C model".
- 11. Click [Finish] in the [Add Standard TCP/IP Printer Port Wizard] dialog box.**

The installation start dialog box reappears.
- 12. Check that the port of the selected printer is displayed in [Port:].**
- 13. Configure the default printer as necessary.**
- 14. Click [Continue].**

The printer driver installation starts.
- 15. Select whether or not to open the Status monitor automatically.**
- 16. Click [Next >].**
- 17. Click [Finish] in the installation completion dialog box.**

A message about restarting the computer may appear. Restart the computer to complete installation.

**↓ Note**

- If the message "Digital Signature Not Found" or the [Software Installation], [Hardware Installation] or [Windows can't verify the publisher of this driver software] dialog box appears:

- Click [Yes], [Continue Anyway] or [Install this driver software anyway] to continue the installation.
- A message about restarting the computer may appear. Restart the computer to complete installation.

### Reference

- A message appears if there is a newer version of the printer driver already installed. If there is, you cannot install the printer driver using Auto Run. If you still want to install the printer driver, use [Add Printer]. See p.247 "If a Message Appears during Installation".

## 2

### Using the LPR Port

---

This section explains how to install the printer driver (TCP/IP) and set up the LPR Port.

### Important

- **Only administrators can perform this installation. Log on as a member of the Administrators group.**

**1. Start Windows, and then insert the provided CD-ROM into the CD-ROM drive.**

Quit all applications currently running.

**2. Select an interface language, and then click [OK].**

**3. Click [PCL/RPCS Raster Printer Drivers].**

The software license agreement appears in the [<License Agreement>] dialog box.

**4. Read the entire license agreement carefully. If you accept its terms, click [I accept the agreement.], and then click [Next >].**

**5. Click [Connected via LAN].**

**6. Double-click the printer name or click [+] to display the printer settings.**

The details shown in [Comment:], [Driver:], and [Port:] vary depending on the operating system, printer model, and port.

**7. Click [Port:], and then click [Add].**

**8. Click [LPR Port], and then click [OK].**

If [LPR Port] does not appear, see Windows Help and install it.

**9. Enter the printer's IP address in the [Name or address of server providing lpd] box.**

**10. Enter "lp" in the [Name or address of server providing lpd] box, and then click [OK].**

The port is added.

**11. Check that the port of the selected printer is displayed in [Port:].**

**12. Configure the default printer as necessary.**

**13. Click [Continue].**

The printer driver installation starts

**14. Select whether or not to open the Status monitor automatically.**

15. Click [Next >].

16. Click [Finish] in the installation completion dialog box.

#### ↓ Note

- If the message "Digital Signature Not Found" or the [Software Installation], [Hardware Installation] or [Windows can't verify the publisher of this driver software] dialog box appears:
  - Click [Yes], [Continue Anyway] or [Install this driver software anyway] to continue the installation.
- A message about restarting the computer may appear. Restart the computer to complete installation.

#### 📖 Reference

- A message appears if there is a newer version of the printer driver already installed. If there is, you cannot install the printer driver using Auto Run. If you still want to install the printer driver, use [Add Printer]. See p.247 "If a Message Appears during Installation".

## Using as the Windows Network Printer

This section assumes that the client has already been configured to communicate with a print server. Do not begin the following procedure before the client is set up and configured correctly.

To use the print server, install the printer driver by selecting "Network printer server", and then select the shared printer.

#### ★ Important

- **Only administrators and power users can perform this installation. Log on as a member of the Administrators or Power Users group.**
- **If you print with a print server connected to the printer using the SmartDeviceMonitor port, Recovery Printing and Parallel Printing cannot be used from the client.**
- **If you print with a Windows XP/Vista or Windows Server 2003/2008 print server, notification functions of SmartDeviceMonitor may not be used with the client.**

1. **Start Windows, and then insert the provided CD-ROM into the CD-ROM drive.**

Quit all applications currently running.

2. **Select an interface language, and then click [OK].**

3. **Click [PCL/RPCS Raster Printer Drivers].**

The software license agreement appears in the [<License Agreement>] dialog box.

4. **Read the entire license agreement carefully. If you accept its terms, click [I accept the agreement.], and then click [Next >].**

5. **Click [Connected via LAN].**

6. **Select the [Printer Name:] check box to select the printer models you want to use.**

The printer name can be changed in the [Change settings for 'Printer Name'] box.

**7. Double-click the printer name or click [+] to display the printer settings.**

The details shown in [Comment:], [Driver:], and [Port:] vary depending on the operating system, printer model, and port.

**8. Click [Port:], and then click [Add].**

**9. Click [Network Printer], and then click [OK].**

**10. Double-click the computer name you want to use as a print server in the [Browse for Printer] window.**

**11. Select the printer you want to use, and then click [OK].**

**12. Check that the port of the selected printer is displayed in [Port:].**

**13. Configure the user code as necessary.**

For an RPCS raster printer driver, a user code can be set after the printer driver installation. For information about user code, see the printer driver Help.

**14. Select the [Default Printer] check box to configure the printer as default.**

**15. Click [Continue].**

The printer driver installation starts.

**16. Select whether or not to open the Status monitor automatically.**

**17. Click [Next >].**

**18. Click [Finish] in the installation completion dialog box.**

**Note**

- If the message "Digital Signature Not Found" or the [Software Installation] , [Hardware Installation] or [Windows can't verify the publisher of this driver software] dialog box appears:
  - Click [Yes], [Continue Anyway] or [Install this driver software anyway] to continue the installation.
- A message about restarting the computer may appear. Restart the computer to complete installation.

**Reference**

- A message appears if there is a newer version of the printer driver already installed. If there is, you cannot install the printer driver using Auto Run. If you still want to install the printer driver, use [Add Printer]. See p.247 "If a Message Appears during Installation".
- p.70 "Setting Up a Server"

---

## Installing the DeskTopBinder - SmartDeviceMonitor for Client

---

Follows the procedure below to install the Installing DeskTopBinder - SmartDeviceMonitor for Client.

**Important**

- **Only administrators can perform this installation. Log on as a member of the Administrators group.**

- **Install SmartDeviceMonitor for Client before installing the printer driver when using the SmartDeviceMonitor for Client port.**

You can install SmartDeviceMonitor for Client in either of the following two ways:

### Full install

Installs all modules.

### Custom Install

You can select which modules to install.

This section explains the procedure for Full install.

1. **Start Windows, and then insert the provided CD-ROM into the CD-ROM drive.**

Quit all applications currently running.

2. **Select an interface language, and then click [OK].**
3. **Click [DeskTopBinder - SmartDeviceMonitor for Client].**
4. **Select the language to be used for installation, and then click [Next >].**
5. **Click [Next >].**
6. **The software license agreement appears in the [<License Agreement>] dialog box. After reading through its contents, click [Yes] to accept it.**
7. **Click [Full install].**
8. **Select the folder in which you want to install the files, and then click [Next >].**
9. **Register the Program folder.**
10. **Click [Next >].**
11. **Check the specified setting, and then click [Next >].**
12. **Click [Complete].**

If you are required to restart the computer after installing SmartDeviceMonitor for Client, restart the computer.

#### ↓ Note

- After inserting the CD-ROM, the [Printer Drivers, Manuals, Utilities] dialog box appears. If it does not, double-click the CD-ROM drive icon under [My Computer] or [Explorer], and then double-click [Setup.exe].

# Paper

This section explains the available paper types and how to load paper.

## Compatible Paper Types

2

You can use various types of paper.

- Plain paper  
This paper is normally used for copying and printing. Unlike inkjet plain paper or glossy paper, it is uncoated.
- Inkjet plain paper  
This extra-white plain paper makes the printed colors appear more vivid. Since it does not have an ink-absorbent coating, you can write on it and use it for photocopying, just like regular plain paper.
- Glossy paper  
This machine prints best on glossy paper for laser. For details the types of glossy paper, contact your sales or service representative.
- Envelopes  
For details about the types of envelope that can be used, see Paper Handling Precautions.
- Thick paper  
For details about the types of thick paper that can be used, see Paper Handling Precautions.

### Note

- All types of paper besides thick paper can be loaded in tray 1.





### Reference

- p.87 "Paper Handling Precautions"

## Loadable Paper Sizes and Quantities

You can load in each tray the paper of the following size and number.

### Tray 1

| Type                       | Size  | Paper capacity                            |
|----------------------------|---|---|
| Plain / Inkjet Plain Paper | A4 (210 × 297 mm)      | Maximum paper capacity: 250 sheets        |
|                            | A5 (148 × 210 mm)      |   |
|                            | A6 (105 × 148 mm)      | Maximum paper output capacity: 100 sheets |
|                            | B5 JIS (182 × 257 mm)  |   |

| Type                       | Size   | Paper capacity  |
|----------------------------|--|---|
|                            | Letter (8 <sup>1</sup> / <sub>2</sub> " × 11")<br>Legal (8 <sup>1</sup> / <sub>2</sub> " × 14")<br>8 <sup>1</sup> / <sub>2</sub> " × 5 <sup>1</sup> / <sub>2</sub> "<br>Executive (7 <sup>1</sup> / <sub>4</sub> " × 10 <sup>1</sup> / <sub>2</sub> "<br>8" × 13"<br>8 <sup>1</sup> / <sub>2</sub> " × 13"<br>8 <sup>1</sup> / <sub>4</sub> " × 13"<br>16K |   |
| Plain / Inkjet Plain Paper | Custom paper sizes<br>Vertical: 139.7- 356.0 mm<br>(5.50- 14.01 inch), Horizontal:<br>88.0- 216.0 mm (3.46- 8.50<br>inch)  | Maximum paper capacity: 250<br>sheets<br>Maximum paper output<br>capacity: 100 sheets |
| Glossy Paper               | A4 (210 × 297 mm)  | Maximum paper capacity: 250<br>sheets<br>Maximum paper output: 1 sheets               |
| Envelope                   | Com10 Envelope (4 <sup>1</sup> / <sub>8</sub> " ×<br>9 <sup>1</sup> / <sub>2</sub> ")<br>Monarch Envelope (3 <sup>7</sup> / <sub>8</sub> " ×<br>7 <sup>1</sup> / <sub>2</sub> ")<br>C6 Envelope (114 × 162 mm)<br>C5 Envelope (162 × 229 mm)<br>DL Envelope (110 × 220 mm)   | Maximum paper capacity: 20<br>sheets<br>Maximum paper output<br>capacity: 20 sheets   |

**Tray 2/Tray 3**







| Type                       | Size   | Paper capacity  |
|----------------------------|--|---|
| Plain / Inkjet Plain Paper | A4 (210 × 297 mm)<br>A5 (148 × 210 mm)<br>A6 (105 × 148 mm)<br>B5 JIS (182 × 257 mm)<br>Letter (8 <sup>1</sup> / <sub>2</sub> " × 11") | Maximum paper capacity: 500<br>sheets<br>Maximum paper output<br>capacity: 100 sheets |

| Type                       | Size   | Paper capacity  |
|----------------------------|--|---|
|                            | Legal (8 <sup>1</sup> / <sub>2</sub> " × 14")<br>Executive (7 <sup>1</sup> / <sub>4</sub> " × 10 <sup>1</sup> / <sub>2</sub> ")<br>8" × 13"<br>8 <sup>1</sup> / <sub>2</sub> " × 13"<br>8 <sup>1</sup> / <sub>4</sub> " × 13"<br>16K |   |
| Plain / Inkjet Plain Paper | Custom paper sizes<br>Vertical: 148.0 - 356.0 mm<br>(5.83 - 14.01 inch), Horizontal:<br>105 - 216.0 mm (4.14 - 8.50<br>inch)   | Maximum paper capacity: 500<br>sheets<br>Maximum paper output<br>capacity: 100 sheets |
| Glossy Paper               | A4 (210 × 297 mm)  | Maximum paper capacity: 500<br>sheets<br>Maximum paper output:<br>1 sheets            |

**Bypass Tray Unit**

| Type                       | Size  | Paper capacity  |
|----------------------------|---|---|
| Plain / Inkjet Plain Paper | A4 (210 × 297 mm)<br>A5 (148 × 210 mm)<br>A6 (105 × 148 mm)<br>B5 JIS (182 × 257 mm)<br>Letter (8 <sup>1</sup> / <sub>2</sub> " × 11")<br>Legal (8 <sup>1</sup> / <sub>2</sub> " × 14")<br>8 <sup>1</sup> / <sub>2</sub> " × 5 <sup>1</sup> / <sub>2</sub> "<br>Executive (7 <sup>1</sup> / <sub>4</sub> " × 10 <sup>1</sup> / <sub>2</sub> ")<br>8" × 13"<br>8 <sup>1</sup> / <sub>2</sub> " × 13"<br>8 <sup>1</sup> / <sub>4</sub> " × 13"<br>16K | Maximum paper capacity: 100<br>sheets<br>Maximum paper output<br>capacity: 100 sheets |
| Plain / Inkjet Plain Paper | Custom paper sizes <sup>*1</sup><br>Vertical: 127.0-1295.4 mm<br>(5.00-51.00 inch), Horizontal:   | Maximum paper capacity: 100<br>sheets<br>Maximum paper output                         |



| Type         | Size   | Paper capacity  |
|--------------|--|---|
|              | 55.0-216.0 mm (2.17-8.50 inch)   | capacity: 100 sheets  |
| Glossy Paper | A4 (210 × 297 mm)   | Maximum paper capacity: 100 sheets<br>Maximum paper output: 1 sheets          |
| Envelope     | Com10 Envelope (4 <sup>1</sup> / <sub>8</sub> " × 9 <sup>1</sup> / <sub>2</sub> ") <br>Monarch Envelope (3 <sup>7</sup> / <sub>8</sub> " × 7 <sup>1</sup> / <sub>2</sub> ") <br>C6 Envelope (114 162 mm) <br>C5 Envelope (162 × 229 mm) <br>DL Envelope (110 × 220 mm)  | Maximum paper capacity: 10 sheets<br>Maximum paper output capacity: 20 sheets |
| Thick        |  | Maximum paper capacity: 20 sheets<br>Maximum paper output capacity: 20 sheets |

\*1 Under the PCL driver, the available custom size is 139.7-355.9mm (5.50-14.01 inch) (Vertical) ×55.0-216.0 mm (2.17-8.50 inch) (Horizontal).

#### Note

- Thick paper: 157 g/m<sup>2</sup> (42 lb.) or more

## Paper Handling Precautions

To ensure optimum print results, take care when handling paper before and after printing.

### Loading Precautions

To ensure correct printing, handle the paper carefully.

Cautions when Loading Paper

- Pull the tray completely out before loading it with paper.
- Load only supported paper in the paper tray.
- Load paper with the print side face down in the paper trays.

- Load paper with the paper grain parallel to the feed direction.
- Do not load paper of different types at the same time.
- To load a different type of paper than that already loaded, first remove all currently loaded paper.
- Do not stack paper over the limit mark.

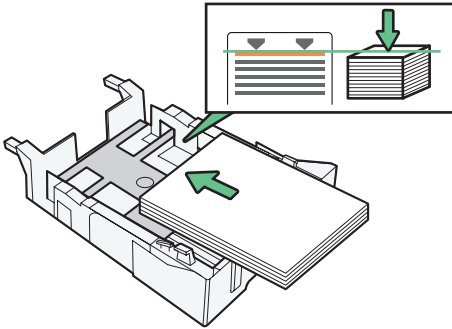

BPR122S

- Curled paper may jam. Straighten any curls within 2 mm (0.08 inches) before loading.

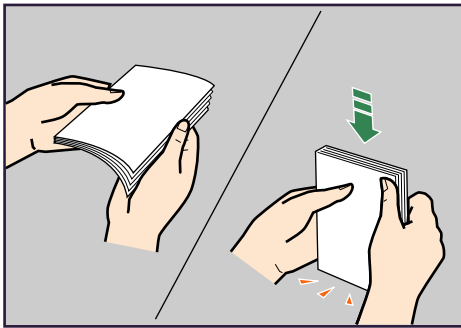

BPR139S

- Before loading envelopes, make sure their edges are sharply creased by rubbing the edges with a pen or similar object.

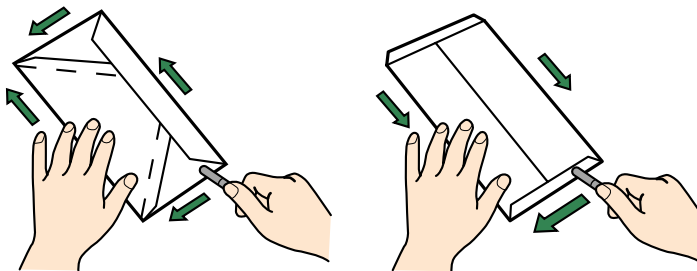

BPR165S

### Correct Orientation of Pre-printed Paper When Loaded in the Tray 1/Tray 2/Tray 3

Load paper print side down, shorter edge pointing in the paper feed direction.

Set paper according to the orientation of the print image, as follows.

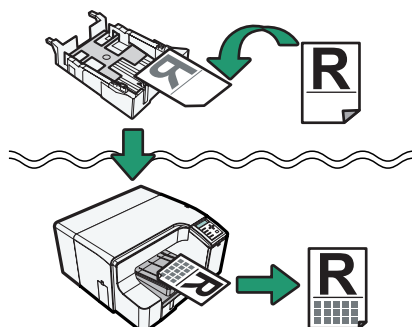

BUG132S

2

### Compatible Paper Sizes for the Duplex Unit

| Type                       | Size                         | Paper capacity |
|----------------------------|------------------------------|----------------|
| Plain / Inkjet Plain Paper | A4 (210 × 297 mm)            |                |
|                            | A5 (148 × 210 mm)            |                |
|                            | A6 (105 × 148 mm)            |                |
|                            | B5 JIS (182 × 257 mm)        |                |
|                            | Letter (8 1/2" × 11")        |                |
|                            | 8 1/2" × 5 1/2"              |                |
|                            | Executive (7 1/4" × 10 1/2") |                |
| 16K                        |                              |                |

### Correct Orientation of Pre-printed Paper When Loaded in the Bypass Tray

Load paper print side up, shorter edge pointing in the paper feed direction.

Set paper according to the orientation of the print image, as follows.

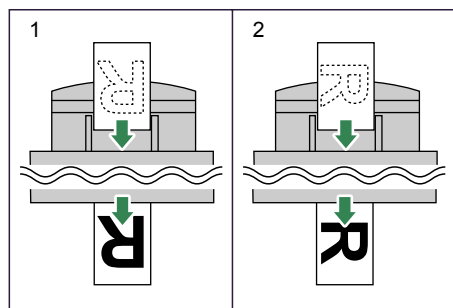

BPR120S

**1. To print over a portrait image:**

Load paper so that its top edge is pointing in the paper feed direction.

**2. To print over a landscape image:**

Load paper so that its right edge is pointing in the paper feed direction.

**2**

---

## Paper Storage Precautions

---

This section gives cautions on storing paper.

If stored under adverse conditions, even paper suitable for printing can cause paper jams, poor print quality, or machine malfunctions. When you store paper, keep the following points in mind:

- Do not store paper in humid places.
- Do not store paper in direct sunlight.
- Store paper flat.
- Store unused paper in the original package.

---

## Paper Type Precautions

---

### Plain paper

- Use the bypass tray to print on thick paper (157 g/m<sup>2</sup> (42 lb.) or more).
- The only type of A6 (105 × 148 mm (4.2 × 5.9 inches)) paper that can be loaded in tray 1 is that of 104.7g/m<sup>2</sup> (28.0 lb.).
- After printing, some types of paper take longer than others to dry. With duplex printing, the ink may smear or rub off. Using the printer driver, specify how long to wait for the prints to dry between printing each side of a duplex sheet. For details, see the printer driver Help.

### Inkjet plain paper

- When printing on inkjet plain paper, in the printer properties dialog box, click [Inkjet Plain Paper]. This allows printing at higher quality.
- In the printer properties dialog box, when [Inkjet Plain Paper] is selected, only one-sided printing is possible. To print on both sides of a sheet, click [Plain].
- Use as soon as possible after opening the package.

### Glossy paper

- The time it takes for the ink to dry depends on the kind of printed image and the environmental conditions.
- If the temperature exceeds 25°C or the relative humidity exceeds 50%, problems with continuous feeding of glossy paper might occur. If this is the case, feed the sheets one by one.
- If you load multiple sheets of glossy paper and they do not feed in properly, feed them one by one.

- Ink smearing can be caused by environmental conditions (such as high humidity) and the type of image being printed (such as ink-heavy images). If smearing occurs, set [Print Quality] to [Quality priority] or [Speed priority]. This may stop the ink smearing.
- Roller marks might appear on printed images.
- If paper is fed from the bypass tray, roller marks might appear on the printed image.
- To ensure water and oil resistance, leave the printed sheet to dry for about a day.
- Some print images can cause the paper to curl, which creates patchy print. If this happens, set [Print Quality] to [Quality priority].
- When using these sheets, see the instructions supplied with them.
- Duplex printing is not supported.

### Envelopes

- Up to 20 envelopes can be loaded in tray 1.
- Flatten envelopes.
- Load envelopes carefully, because the printable area depends on the orientation.
- Set the envelope selector to the rear position  before printing.
- Duplex printing is not supported.

### Thick paper

- Thick paper is heavier than 157 g/m<sup>2</sup> (42 lb.).
- You can insert paper with weights up to 255 g/m<sup>2</sup> (60 lb.) into the bypass tray.
- Insert paper with the print side face up into the bypass tray.
- Duplex printing is not supported.

### Cautions to Observe After Printing

Depending on the paper type, the ink may take a while to dry. Before handling, make sure printed sheets have fully dried. Otherwise, the ink may smudge.

#### Note

- The ink may smear depending on the type of image. If this happens, set the envelope selector to the rear position .

### Non-compatible Paper

Check if the paper is compatible.

Do not use paper that is:

- wrinkled, folded, or damaged
- wavy at the ends
- curled

- absorbent
- dry and conducive to static buildup
- already printed on (such as the back of pre-printed paper)
- pre-printed (unless specified)
- heat sensitive/non-carbon
- too thick or thin
- pre-stitched
- glued or tacked
- stapled or clipped together
- dark in places
- irregular in length and proportion

**Note**

- Even if compatible paper types are used, print quality may be lower than usual or paper jams may occur if the paper was improperly stored.

### Printable Area

---

Printable and unprintable areas

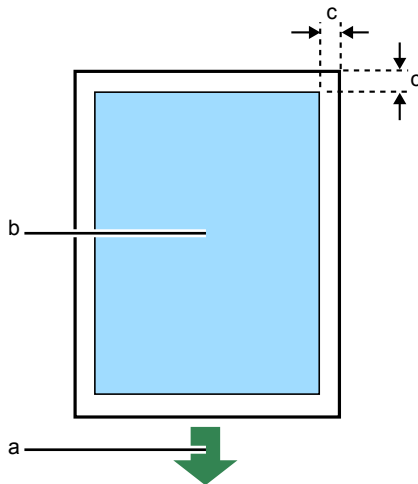

BPR195S

- a. Output Direction
- b. Printable Area
- c. 3 mm (0.12 inches)

When printing on envelopes, the following print area limitations apply.

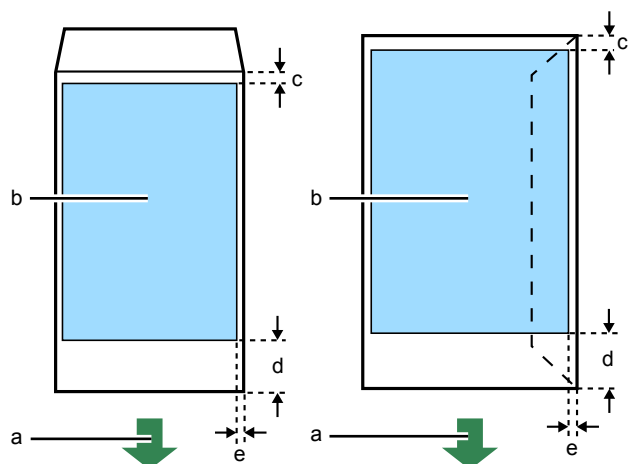

- a. Output Direction
- b. Printable Area
- c. 8 mm (0.4 inches)
- d. 38 mm (1.5 inches)
- e. 3 mm (0.2 inches)

# Specifying the Paper Settings using the Printer's Control Panel (Paper Input Menu)

This section explains the settings you can specify in the Paper Input menu, such as those for the size and type of the paper loaded in each tray.

The very first time you load paper or anytime you change to a different size or type of paper, you must specify the paper settings using "Paper Input Menu" on the printer's control panel.

## Tray Paper Size

You can specify the size of the paper loaded in the paper feed tray.

## Paper Type

You can specify the type of the paper loaded in the paper feed tray.

## Aut.Tray Select

You can specify whether or not to automatically select the tray according to the paper size and paper type.

## Tray Priority

You can specify the prioritized paper feed tray. This setting is factory-preset to "tray 1".

### ↓ Note

- "Aut.Tray Select" can be specified only if the optional bypass tray or the optional paper feed unit is attached.
- If you select "Aut.Tray Select", the tray is automatically selected according to the paper size set for the trays in "Tray Paper Size".

### 📖 Reference

- p.84 "Compatible Paper Types"
- p.84 "Loadable Paper Sizes and Quantities"

---

## Changing the Paper Input Menu

---

The following procedure is an example of setting the Tray Paper Size.



1. On the control panel, press the [Menu] key.

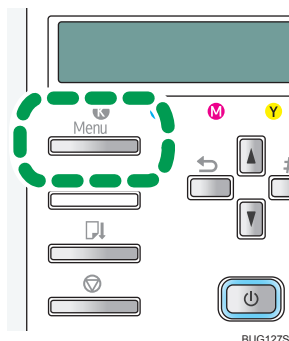

2. Press the [▲] or [▼] key to display [Paper Input], and then press the [#Enter] key.

```
Menu:
Paper Input
```

3. Press the [▲] or [▼] key to display [Tray Paper Size], and then press the [#Enter] key.

```
Paper Input:
Tray Paper Size
```

4. Press the [▲] or [▼] key to display the tray you want to specify, and then press the [#Enter] key.

```
Tray Paper Size:
Tray 1
```

5. Press the [▲] or [▼] key to display appropriate paper size, and then press the [#Enter] key.

```
Tray 1:
*A4 (210 x 297)
```

The setting is applied, and then, the Paper Input menu reappears.

6. Press the [Online] key.

The initial screen appears.



# 3. Printer Driver

---

## Two Types of Printer Properties Dialog Box

There are two types of printer properties dialog box, namely: Custom Setting and Multi-tab. The default is Custom Setting.

- Custom Setting

This type is suitable for users who rarely need to change printer properties settings and print using generally the same settings. Custom setting may change depending on the printer's system configuration.

- Multi-tab

This type is suitable for users who often need to change printer properties settings and print using a variety of settings.

To change the default Custom Setting to Multi-tab, do the following:

1. Click the [Printer Configuration] tab.
2. In the [Window type] area, click [Multi-tab].
3. Click [OK].

---

### Opening the Printer Properties Dialog Box

---

This section explains how to open the printer properties dialog box from the [Printers and Faxes] window. Depending on the operating system settings, the actual procedure may differ.

1. On the [Start] menu, click [Printers and Faxes].
2. Click the icon of the printer, and then click [Properties] on the [File] menu.

The printer properties dialog box appears.

3. Click [Printing Preferences...].

---

### Opening the Printing Preferences Dialog Box

---

This section explains how to open the [Printing Preferences] dialog box from the [Printers and Faxes] window.

Depending on the operating system settings, the actual procedure may differ.

1. On the [Start] menu, click [Printers and Faxes].

2. Click the icon of the printer, and then click [Printing Preferences...] on the [File] menu.

The printing preferences dialog box appears.

---

## Opening from an Application

---

If you open the printer properties dialog box from an application, the factory settings appear. Change the settings as required and carry out printing.

Changes made here are only applicable with that application and only as long as that application stays open.

Some applications may automatically change the printer properties settings.

The procedure below is an example for Paint (included in the standard Windows package).

How to open the printer properties dialog box differs depending on the application. From most applications, the printer properties dialog box can be opened by clicking [Print...] or [Page Setup...] on the [File] menu, and then clicking [Properties] (Windows XP/Vista, Windows Server 2003/2008: [Preferences]). For details, see Help of the application.

1. On the [File] menu, click [Print...].
2. In the Name list, select the name of this printer, and then click Properties (Windows XP/Vista, Windows Server 2003/2008: Preferences).

The printer properties dialog box (Windows XP/Vista, Windows Server 2003: the [Printing Preferences] dialog box) appears.

# Specifying Settings on [Accessories] Tab

If the printer and computer are not configured for bidirectional communication, open the printer driver and specify the optional units attached to the printer and the size and type of paper loaded in the printer.

---

## Conditions for Bidirectional Communication

---

Bidirectional communication allows information about paper size and feed direction settings to be automatically sent to the printer. You can check printer status from your computer.

If you use the RPCS raster printer driver and bidirectional communication is enabled, the [Accessories] tab is unavailable.

To support bidirectional communication, the following conditions must be met:

### If the machine and computer are connected directly to each other with a USB cable

- The computer must support bidirectional communication.
- The printer must support bidirectional communication.

### When connected with the network

- The printer must support bidirectional communication.

---

## If Bidirectional Communication is Disabled

---

Perform this procedure only if the printer and computer are not communicating bidirectionally. This procedure enables you to display the printer driver settings, specify which optional units are installed, and specify the size and type of paper loaded in the printer.

### Windows 2000/Vista

1. On the [Start] menu, point to [Settings] (Windows Vista: [Hardware and Sound] in [Control Panel]), and then click [Printers].  
The [Printers] window appears.
2. Click the icon of the printer you want to use.
3. On the [File] menu, click [Properties] (Windows Vista: Right-click the icon of the printer, and then click [Properties]).

When you open the printer properties dialog box for the first time after installing the printer driver, or if you have not specified the attached options yet, a prompt to specify the options appears.

4. Click [OK].

**5. Click the [Accessories] tab.**

If options in the [Accessories] tab are disabled, bidirectional connection is enabled. In this case, no change is necessary for option settings.

**6. Select options installed from the [Select printer options:] area, and then make the necessary settings.**

**7. Select the appropriate size and type for the tray.**

**8. Click [OK] to close the printer properties dialog box.**

**3**

**Windows XP, Windows Server 2003/2008**

**1. On the [Start] menu, click [Printers and Faxes].**

The [Printers and Faxes] window appears.

Under Windows Server 2003, on the [Start] menu, point to [Settings], and then click [Printers and Faxes].

The [Printers and Faxes] window appears.

Under Windows Server 2008, on the [Start] menu, point to [Settings], and then click [Printers].

The [Printers] window appears.

**2. Click the icon of the printer you want to use.**

**3. On the [File] menu, click [Properties].**

When you open the printer properties dialog box for the first time after installing the printer driver, or if you have not specified the attached options yet, a prompt to specify the options appears.

**4. Click the [Accessories] tab.**

**5. Select options installed from the [Select printer options:] area, and then make the necessary settings.**

**6. Select the appropriate size and type for the tray.**

**7. Click [OK] to close the printer properties dialog box.**

**↓ Note**

- Manage Printers permission is required to change the printer properties in the [Printers] folder. Log on as an Administrators or Power Users group member.
- If you are using the SmartDeviceMonitor for Client Port to share the printer as a print server, bidirectional communication between the printer and a client PC will not be possible.
- If you add an optional tray to an existing printer, you must refresh the settings on the printer's [Accessories] tab.

# Printing

Follow the procedure below to print on plain paper.

## ★ Important

- You can load 100 sheets in the optional bypass tray unit.
- Curled paper may jam. Straighten any curls within 2 mm (0.08 inches) before loading.
- Load paper with the print side face down in the paper trays.
- Load paper with the print side face up in the optional bypass tray unit.
- When printing on both sides, content other than text is printed at lower density.
- If ink smears appear and characters are not properly formed when printing white text on a black background, select [High speed] or [Speed priority] in the [Print Quality] area, and then print the job again.
- Printing on envelopes
  - Before loading envelopes, make sure their edges are sharply creased by rubbing the edges with a pen or similar object.
  - Squeeze the paper guide release, and then slide the paper guides into position according to the paper size.

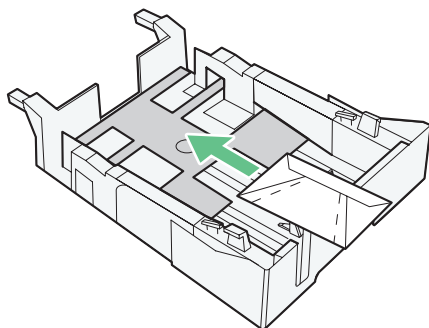

BPR133S

### 1. Load plain paper into tray.

How to load paper depends on the paper type.

### 2. Open the printer properties dialog box from the application.

### 3. Select the paper type from the [Paper type:] list.

After selecting the paper type as required, switch the envelope selector to "⏏".

If you select [Inkjet Plain Paper], the machine will print on one side only. To print on both sides, select [Plain].

### 4. Make the necessary settings, and then click [OK].

The printer properties dialog box closes.

### 5. Make print settings, and then click [OK].

#### ↓ Note

- If you set [Paper type:] to [Glossy Paper] in the printer properties dialog box, be sure to remove each sheet as it is delivered to the output ramp.
- You can load up to 20 envelopes.

#### 📖 Reference

- p.97 "Two Types of Printer Properties Dialog Box"
- p.87 "Paper Handling Precautions"
- p.92 "Printable Area"

3

## Unauthorized Copy Control

To prevent unauthorized copying, you can embed patterns and text beneath the print. You do not need a special paper to use this function. If a paper with text or image patterns is copied by a copier or a multi-function printer, either the patterns are printed vividly or the copy is grayed out, so as to protect the information on the original from leaking. To print with protection against unauthorized copying, you can use [Data security for copying] and [Mask type:].

#### ★ Important

- **This function is designed to discourage copying confidential documents; it does not prevent unauthorized use of information.**

In the printer properties dialog box, click [Setup] tab to select the [Unauthorized copy...] check box.

#### Printing a document using [Data security for copying]

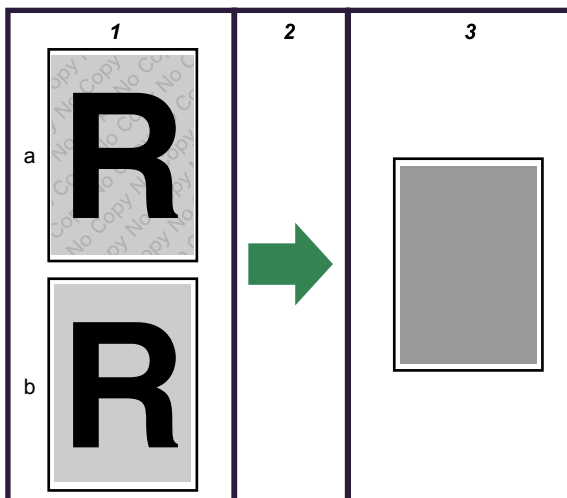

BPR199S



**1. The pattern and text you have set is printed.**

- a: Text
- b: Pattern

**2. The document is copied to the machine that the Copy Data Security unit is installed.**

**3. The document is blanked by gray overprint.**

**Printing a Document Using [Mask type:]**

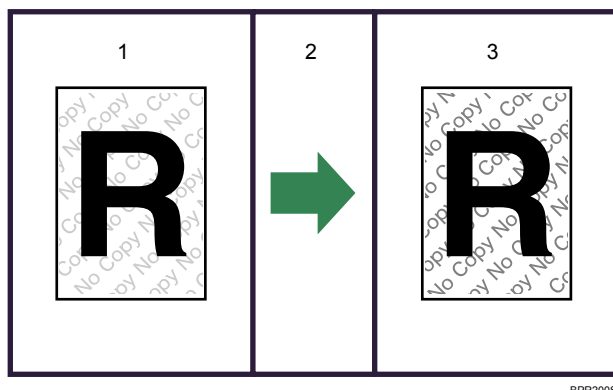

**1. The print preview of the pattern and the text you set is displayed.**

**2. The document is copied to the copier or the multifunction machine.**

**3. The pattern and the text you set appear.**

**Note**

- When selecting [High speed], [Unauthorized copy...] is not available.
- When selecting [Economy Color], [Unauthorized copy...] is not available.
- When selecting [Use error diffusion] and [Whole page], [Unauthorized copy...] is not available.

**Important Notice**

- The supplier does not provide warranty regarding the appearance of print patterns and other copy protection features. The appearance of the print patterns and the performance of Unauthorized Copy Control may vary depending on the quality of paper used and the machine model and settings.
- The supplier takes no responsibility for any damages sustained in connection with use of or inability to make use of Unauthorized Copy Control print patterns.

**Note**

- For details, see the printer driver Help.

# Canceling Printing

Print jobs can be canceled from either a printer or computer. How to cancel print jobs differs according to their job status. Check the job status first.

## Canceling a Print Job Being Printed

Cancel the print job from the Status monitor or by pressing the [Job Reset] key of the printer.

## Canceling a print job in queue

Cancel the print job from the taskbar of the computer.

3

## Canceling Printing from the Status Monitor

Follow the procedure below to cancel a print job being printed.

1. Check that printing and the Status monitor have started.
2. Click [Stop Printing].

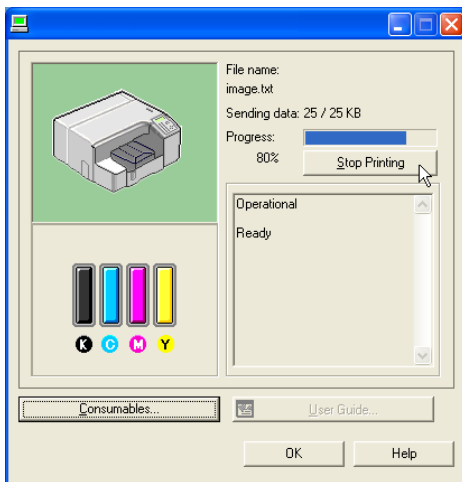

It will take a few moments for printing to stop.

### Reference

- p.109 "Using the Status Monitor"

## Canceling Printing Using the [Job Reset] Key of the Printer

Follow the procedure below to cancel a print job being printed.

1. Check that printing has started.

Not only the print job being printed but also the print jobs in queue will be canceled.

If you press the [Job Reset] key while the printer is receiving print data for a print job (the Data in lamp is blinking), that print job is also canceled.

**2. Press the [Job Reset] key.**

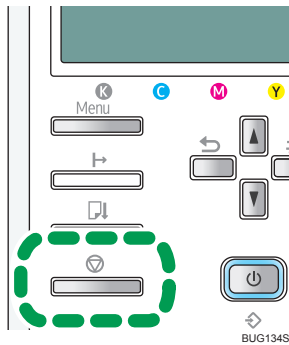

The confirmation screen appears.

**3. Press the [#Enter] key.**

It will take a few moments for printing to stop.

## Canceling Printing from the Taskbar

Follow the procedure below to cancel a print job in queue.

1. Double-click the icon of the printer on the taskbar.
2. Select the print job you want to cancel, and then click Cancel on the Document menu.

# Selecting the Printer Driver Language

This section explains how to select the language used for the settings and messages displayed on the Printer Driver.

3

1. Open the printer properties dialog box.
2. Click [Printing Preferences].
3. Click the [Printer Configuration] tab.
4. Click [Environment Settings...].
5. In the [Language:] list, select the language you require.
6. Click [OK].
7. Click [OK].

Use the following procedure to change the language setting.

1. Open the printer properties dialog box.
2. Click Printing Preferences.
3. Click the [Printer Configuration] tab (1).

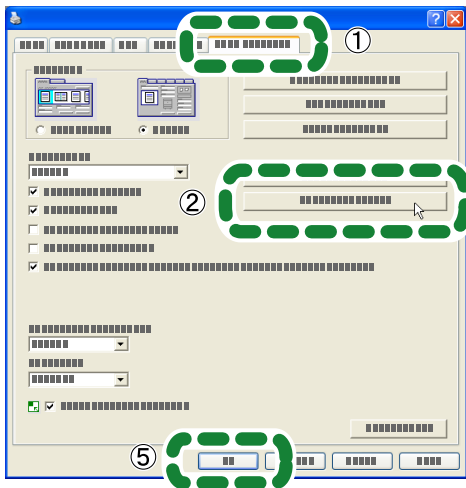

BPR203S

4. Click [Environment Settings...] (②).

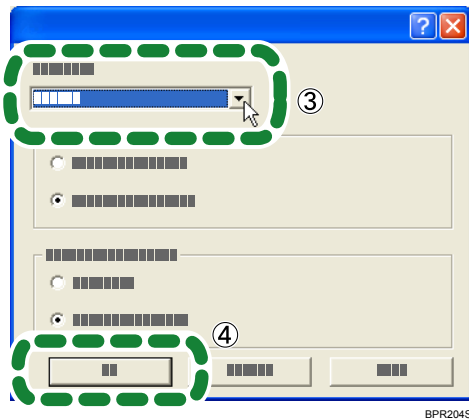

5. In the language list (shown below), find the language you require.

The languages in the list appear in the following order:

- 1. Japanese
- 2. English
- 3. German
- 4. French
- 5. Italian
- 6. Spanish
- 7. Dutch
- 8. Swedish
- 9. Danish
- 10. Norwegian
- 11. Portuguese
- 12. Russian
- 13. Finnish
- 14. Czech
- 15. Hungarian
- 16. Polish

6. In the [Language:] list, select the language you require (③).
7. Click [OK] (④).
8. Click [OK] (⑤).



# 4. Monitoring and Configuring the Printer

---

## Using the Status Monitor

Using the Status monitor, you can check the print job status, error messages amount of remaining ink, and other printer status information.

### Reference

- p.191 "Replacing a Print Cartridge"
- p.254 "Status Monitor Errors"
- p.104 "Canceling Printing from the Status Monitor"

---

## Receiving Notification of Print Job Status via the Status Monitor

---

You can specify how to receive notification of print job status via the Status monitor.

1. Open the printer properties dialog box.
2. Click the [Maintenance] tab.
3. Click [Status Monitor Settings].
4. From the list in the [Status Monitor display settings] area, select a method for launching the Status monitor.
5. Press [OK].
6. Press [OK].

## Using SmartDeviceMonitor for Client

SmartDeviceMonitor for Client is an application that has functions such as the peer-to-peer printing machine monitoring. We recommend you install this application on the client computer.

- Operating System: Windows 2000  
Protocol Stack  
TCP/IP protocol supplied with Windows 2000
- Operating System: Windows Server 2003  
Protocol Stack  
TCP/IP protocol supplied with Windows Server 2003
- Operating System: Windows XP  
Protocol Stack  
TCP/IP protocol supplied with Windows XP
- Operating System: Windows Vista  
Protocol Stack  
TCP/IP protocol supplied with Windows Vista
- Operating System: Windows Server 2008  
Protocol Stack  
TCP/IP protocol supplied with Windows Server 2008

### What can you do with it?

Using SmartDeviceMonitor for Client, you can do the following:

- Peer-to-peer printing
  - Send print jobs directly to the network printer without going through a print server.
  - Print using a substitute printer if there are too many jobs waiting on the specified printer, or if an error disables printing (Recovery Printing).
  - Allocate multiple print jobs to multiple printers (Parallel Printing).
  - Preregister groups of printers specified for Recovery Printing or Parallel Printing.
- Receive error message notification if an error occurs in the machine while it is printing or sending a job.
- Monitoring function
  - Check the printer status such as the remaining amount of paper while printing.
  - Simultaneously monitor multiple printers in use.
  - Check the printer's network settings and system configuration.
- Be notified of print completion.



- View up to 100 print jobs that belong to you.

#### ↓ Note

- The status monitor function might not be able to monitor all possible items or events.

## Using Notification via SmartDeviceMonitor for Client

This section explains how to use the Notification function in SmartDeviceMonitor for Client.

If a client computer uses SmartDeviceMonitor for Client to access a network printer, you can specify the Notification setting to allow the computer to receive print job status notification.

#### ★ Important

- To change the printer properties in the [Printer] folder, you must have access to "Printer Management access authentication". To make this possible, log on as a member of the Administrators or Power Users group.

#### 📖 Reference

- p.70 "Sharing the Printer"

## Specifying the Print Server

Follow the procedure below to make the settings on the print server.

#### ★ Important

- To change the print server setting, you must have access to "Printer Management access authentication". To make this possible, log on as a member of the Administrators or Power Users group.

1. On the [Start] menu, point to [All Programs], point to [DeskTopBinder], [SmartDeviceMonitor for Client], and then click [Print Server Setting].

The Print Server Setting dialog box appears.

2. Select the [Notify client PCs of printout/data-transmission] check box, and then click [OK].

Depending on the print server setting, a dialog box appears. Read the message in the dialog box, and then click [OK].

By clicking [Cancel], the changed setting is canceled.

3. A dialog box about specifying the client computer setting appears. Click [OK].

The print server setting has been changed. However, you still need to specify the Notification setting on each client computer.

#### ↓ Note

- When the spooler stops, the print job in progress is completely reprinted.
- If [Extended Features] was not used, it is automatically enabled.

## Specifying the Client Computer Settings

---

Follow the procedure below to make the settings on the client.

1. On the [Start] menu, point to [All Programs], point to [DeskTopBinder], [SmartDeviceMonitor for Client], and then click [Extended Features Settings].

The Extended Features Settings dialog box opens.

2. Select the [Use Extended Features] check box.
3. Select the [Notify of printout/ data-transmission when using print server] check box in "Notification".
4. Click [OK].

The Extended Features dialog box closes.

Specifying the client computer settings is now complete.

4

---

## Specifying the Settings for Monitoring the Printer

---

Use SmartDeviceMonitor for Client to monitor the status of the printer.

To use SmartDeviceMonitor for Client, you must make the following settings:

1. **Launch SmartDeviceMonitor for Client.**

The SmartDeviceMonitor for Client icon appears in the taskbar's system tray.

This will not appear if you click [Do not show this message again].

2. **Right-click the SmartDeviceMonitor for Client icon, and then, in the pop-up menu, look for the printer you want to monitor.**
3. **If the printer you want to monitor does not appear, point to [Properties], and then click [Monitor Device Settings...].**

The SmartDeviceMonitor for Client - Option dialog box opens.

4. **Select the printer you want to monitor, and then select the [To be Monitored] check box in [Printer Settings].**

If you select the [Display on the task bar menu] check box, you can reflect the printer status in the SmartDeviceMonitor for Client icon in the taskbar system tray.

5. **Click [OK].**

The SmartDeviceMonitor for Client - Settings dialog box closes and the selected printer is monitored.

### ↓ Note

- For details about how the icon indicates the printer status, see the SmartDeviceMonitor for Client Help.

### 📖 Reference

- If you are using the printer in a DHCP environment, see p.290 "Using DHCP".

---

## Displaying the Printer Status

---

You can display the printer status.

**1. Launch SmartDeviceMonitor for Client.**

**2. Right-click the SmartDeviceMonitor for Client icon.**

The printer status is reflected in the SmartDeviceMonitor for Client icon in the taskbar system tray.

**3. To monitor the status in more detail, right-click the SmartDeviceMonitor for Client icon, and then select the printer you want to monitor.**

**4. Click [Printer].**

A dialog box displaying the printer status opens.

**↓ Note**

- For details about the items in the dialog box, see the SmartDeviceMonitor for Client Help.
- For details about how the icon indicates the printer status, see the SmartDeviceMonitor for Client Help.

# Using Web Browser

## Available operations

The following operations can be remotely performed using Web browser from a client computer.

- Displaying printer status or settings
- Resetting the printer
- Making printer settings
- Making e-mail notification settings
- Making network protocol settings
- Making security settings

4

## Configuring the printer

To perform the operations from Web browser, TCP/IP is required. After the printer is configured to use TCP/IP, operations from Web browser become available.

## Recommended Web browsers

- Windows:  
Internet Explorer 6.0 or higher  
Firefox 1.0 or higher
- Mac OS:  
Safari 2.0 or higher  
Firefox 2.0 or higher

### ↓ Note

- If the previous versions of the Web browser above are used, JavaScript and cookies are not enabled with the Web browser used, or the computer's security environment is incompatible with the machine's software, display and operation problems may occur.
- Non-recommended Web browsers might not display certain screen elements correctly.
- If you are using a proxy server, change the Web browser settings. Contact your network administrator for information about the settings.
- The previous page may not appear even after the back button of a Web browser is clicked. If this happens, click the refresh button of a Web browser.
- Updating the printer information is not automatically performed. Click [Refresh] in the display area to update the printer information.

---

## Displaying Top Page

---

This section explains the Top Page and how to display Web browser.

### 1. Launch the Web browser.

### 2. In the Web browser's address bar, enter "http://(printer's IP address)/" to access the printer.

If a DNS or WINS server is in use and the printer's host name has been specified, you can enter the host name instead of the IP address.

The displayed Web page is split into the following areas:

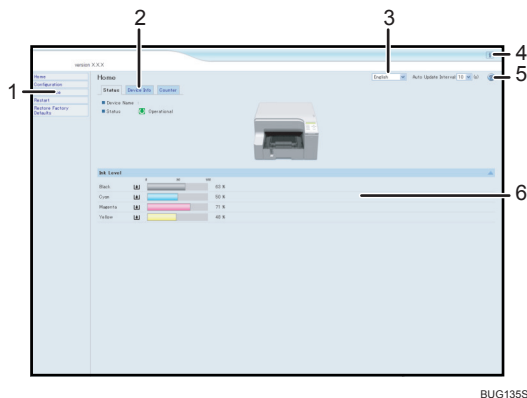

BUG135S

### 1. Menu Area

A menu appears.

When you click an item in the menu area, information about the item appears.

### 2. Tab area

Details about each menu appears.

### 3. Language Selection Menu

Select a language.

If the displayed page is garbled when using an English language operating system, select "English" with the language selection menu.

### 4. Header area

The link to the screen where you can check the firmware version and the link to the administrator log on screen appear here.

### 5. Help

The link to the displayed screen's help section appears here.

### 6. Work Area

Information about an item selected in the menu area appears here.

Information displayed in the work area does not update automatically.

To update the information, click [Refresh] in the upper-right corner of the work area.

To refresh the entire Web browser window, click [Refresh] on the Web browser tool bar.

## Menu

This section explains the items in the Web browser menu.

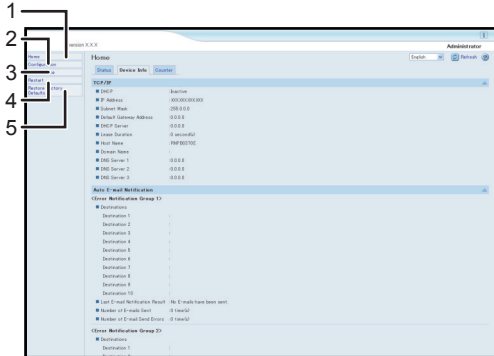

BPR136S

4

### 1. Home

The [Status] and [Device Info] tab are displayed. Details of the tab menu are displayed on the work area.

### 2. Configuration

Make system settings for the machine, interface settings, and security.

### 3. Maintenance

Click to perform printer maintenance.

### 4. Restart

Click to restart the printer and apply the settings.

### 5. Restore Factory Defaults

Click to reset the printer.

## Checking the Printer Status

You can check the printer status.

### 1. Launch the Web browser.

### 2. In the address bar, enter "http://(printer's IP address or host name)/".

The printer's top page appears.

### 3. In the menu area, click the item you want to check.

## Changing the Printer Settings

You can change the printer settings.

1. **Launch the Web browser.**
2. **In the address bar, enter "http://(printer's IP address or host name)/".**
3. **Click [Configuration], and then click [General Settings].**

A dialog box for entering the user name and password opens.

4. **Enter the user name and password, and then click [OK].**

If this is the first time to do this, enter "admin" as the user name and leave the password blank.

To ensure security, it is important you change the password.

5. **Specify the printer settings.**

6. **Click [OK].**

The specified settings are transmitted to the printer.

---

## Notifying the Printer Status by E-mail

---

You can be notified of the printer status by e-mail on an occasion such as if the printer runs out of paper or paper is jammed.

The e-mail notifying the printer status will be sent to the e-mail address specified as the destination in advance.

### Important

- **Depending on your e-mail application, a phishing warning message might appear when you receive e-mail. To stop this warning message appearing, see your e-mail application's Help for details about registering trusted senders.**

You can also specify the timing and status to notify.

The following status can be notified:

- The printer error has occurred.
- The ink has run out.
- The ink will run out soon.
- The Ink Collector Unit must be replaced now.
- The Ink Collector Unit must be replaced soon.
- The paper has run out.
- The paper has been jammed.
- The paper type is wrong.
- The paper size is wrong.
- The paper size and type are wrong.
- A cover is open.

- The paper has been loaded incorrectly.
- The machine is out of its operational temperature range.

**Flowchart showing how to specify notification by e-mail**

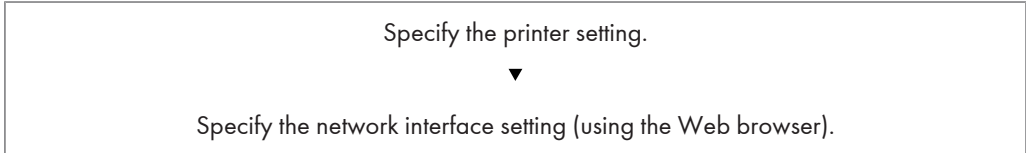

To specify the network interface setting, use the Web browser. This section explains how to specify the network interface setting using the Web browser.

4

**Reference**

- For details about specifying the printer setting, see p.178 "Specifying System Settings using the Control Panel (System Menu)".
- For details about specifying the network interface setting, see p.116 "Changing the Printer Settings".

**Specifying Notification the Printer Status by E-mail**

In E-mail, you can specify the basic and authentication settings for sending e-mails.

**Specifying SMTP Server**

You can specify whether to use SMTP, and specify the SMTP server name and SMTP port number. The "Administrator E-mail Address" will appear in the e-mail message. The "Device E-mail Address" will appear in the "From" box.

| Functions                    | Selectable value                           | Default  |
|------------------------------|--|----------|
| SMTP                         | Active<br>Inactive                         | Inactive |
| SMTP Server Name             | 127 characters max. (1-byte alphanumerics) | None     |
| SMTP Port Number             | 1-65535                                    | 25       |
| Device E-mail Address        | 127 characters max. (1-byte alphanumerics) | None     |
| Administrator E-mail Address | 127 characters max. (1-byte alphanumerics) | None     |



| Functions      | Selectable value   | Default |
|----------------|--|---------|
| Text in E-mail | 255 characters max. (1-byte alphanumerics) (2-byte characters available) | None    |

### Specifying SMTP Authentication

By specifying the SMTP authentication setting, you can send e-mails to destinations where the e-mail server carries out SMTP authentication.

By specifying the SMTP authentication setting, you can log on to SMTP servers which require authentication. The supported authentication protocols are: CRAM MD5, PLAIN, and LOGIN.

If you set [SMTP Authentication Encryption] to [Auto], the printer will try logging on using CRAM MD5, LOGIN, and then PLAIN.

If you set [SMTP Authentication Encryption] to [On], the printer will try logging on using only CRAM MD5. If you set [SMTP Authentication Encryption] to [Off], the printer will try logging on using LOGIN and then PLAIN.

| Functions                      | Selectable value                           | Default            |
|--------------------------------|--|--------------------|
| SMTP Authentication            | Active<br>Inactive                         | Inactive           |
| SMTP Authentication Name       | 191 characters max. (1-byte alphanumerics) | None               |
| SMTP Authentication Password   | 63 characters max. (1-byte alphanumerics)  | None (No Password) |
| SMTP Authentication Encryption | Auto<br>On<br>Off                          | Auto               |

### Specifying POP before SMTP

By specifying the SMTP authentication setting, you can send e-mails to destinations where the e-mail server carries out SMTP authentication.

By using POP before SMTP, you can log on to an SMTP server supporting POP before SMTP.

You can specify whether to use POP before SMTP, and specify the POP server name, POP port number, POP user name, and POP password.

If you set [POP Authentication Encryption] to [Auto], the printer will try logging on by APOP login, and then in plain text.

If you set [POP Authentication Encryption] to [On], the printer will try logging on only by APOP login. If you set [POP Authentication Encryption] to [Off], the printer will try logging on only in plain text.

In standby time following POP authentication (in milliseconds), you can specify how long the printer can wait for logging on to the SMTP server after logging on to the POP server.

| Functions                          | Selectable value                          | Default            |
|------------------------------------|---|--------------------|
| POP before SMTP                    | Active<br>Inactive                        | Inactive           |
| POP Server Name                    | 127 characters max. (1-byte alphanumeric) | None               |
| POP Port Number                    | 1-65535 (1-byte numeric characters)       | 110                |
| POP User Name                      | 127 characters max. (1-byte alphanumeric) | None               |
| POP Password                       | 63 characters max. (1-byte alphanumeric)  | None (no password) |
| POP Authentication Encryption      | Auto<br>On<br>Off                         | Auto               |
| Wait Time after POP Authentication | 0-10000 (millisecond(s))                  | 300                |

### Auto E-mail Notification: Error Notification Group 1-3

#### Group to Notify

| Functions       | Selectable value  | Default |
|-----------------|---|---------|
| Group Name      | 19 characters max. (1-byte alphanumeric)(2-byte characters available) | None    |
| E-mail Language | English<br>Japanese<br>French<br>German                               | English |

| Functions       | Selectable value   | Default |
|-----------------|--|---------|
|                 | Italian<br>Spanish<br>Dutch<br>Swedish<br>Norwegian<br>Danish<br>Portuguese<br>Finnish |         |
| E-mail Language | Polish<br>Czech<br>Hungarian<br>Russian  | English |
| Subject         | 31 characters max. (1-byte<br>alphanumerics) (2-byte<br>characters available)          | None    |
| Text            | 255 characters max. (1-byte<br>alphanumerics) (2-byte<br>characters available)         | None    |

### Destinations

Destination 1-10

| Functions      | Selectable value  | Default |
|----------------|---|---------|
| Name           | 19 characters max. (1-byte<br>alphanumerics) (2-byte<br>characters available) | None    |
| E-mail Address | 127 characters max. (1-byte<br>alphanumerics)                                 | None    |

### Error Notification

This section lists the settings for notification by e-mail.

| Functions                          | Selectable value | Default |
|------------------------------------|------------------|---------|
| Printer Error                      | ON<br>OFF        | OFF     |
| Cartridge Empty                    | ON<br>OFF        | OFF     |
| Cartridge Almost Empty             | ON<br>OFF        | OFF     |
| Replace Ink Collector Unit         | ON<br>OFF        | OFF     |
| Ink Collector Unit Near Full       | ON<br>OFF        | OFF     |
| No Paper                           | ON<br>OFF        | OFF     |
| Paper Misfeed                      | ON<br>OFF        | OFF     |
| Paper Size Mismatch                | ON<br>OFF        | OFF     |
| Paper Type Mismatch                | ON<br>OFF        | OFF     |
| Paper Size and Type Mismatch       | ON<br>OFF        | OFF     |
| Cover Open                         | ON<br>OFF        | OFF     |
| Unit/Cartridge Not Set             | ON<br>OFF        | OFF     |
| Out of Printable Temperature Range | ON<br>OFF        | OFF     |

## Auto E-mail Notification: Counter Notification Group

### Group to Notify

| Functions       | Selectable value  | Default |
|-----------------|---|---------|
| E-mail Language | English<br>Japanese<br>German<br>French<br>Italian<br>Spanish<br>Dutch<br>Swedish<br>Danish<br>Norwegian<br>Portuguese<br>Finnish | English |
| E-mail Language | Polish<br>Czech<br>Hungarian<br>Russian   | English |
| Subject         | 31 characters max. (1-byte<br>alphanumerics) (2-byte<br>characters available)   | None    |

### Destination

Destination 1-10

| Functions      | Selectable value  | Default |
|----------------|---|---------|
| Name           | 19 characters max. (1-byte<br>alphanumerics) (2-byte<br>characters available) | None    |
| E-mail Address | 127 characters max. (1-byte<br>alphanumerics)                                 | None    |

**Counter Notification**

| Functions     | Selectable value | Default |
|---------------|------------------|---------|
| Machine Total | ON<br>OFF        | OFF     |

**Auto E-mail Notification: Error Notification**

---

**Printer Error**

4

| Functions         | Selectable value                               | Default |
|-------------------|--|---------|
| Notify when error | Occurs   | Occurs  |
| Notify within     | 0<br>5<br>10<br>15<br>20<br>25<br>30 (minutes) | 5       |

**Cartridge Empty**

| Functions         | Selectable value                               | Default |
|-------------------|--|---------|
| Notify when error | Occurs<br>Occurs & Fixed                       | Occurs  |
| Notify within     | 0<br>5<br>10<br>15<br>20<br>25<br>30 (minutes) | 5       |

**Cartridge Almost Empty**

| Functions         | Selectable value         | Default |
|-------------------|--------------------------|---------|
| Notify when error | Occurs<br>Occurs & Fixed | Occurs  |
| Notify within     | 10<br>20<br>30 (%)       | 10      |

**Replace Ink Collector Unit**

| Functions         | Selectable value                               | Default |
|-------------------|--|---------|
| Notify when error | Occurs   | Occurs  |
| Notify within     | 0<br>5<br>10<br>15<br>20<br>25<br>30 (minutes) | 5       |

**Ink Collector Unit Near Full**

| Functions         | Selectable value                               | Default |
|-------------------|--|---------|
| Notify when error | Occurs   | Occurs  |
| Notify within     | 0<br>5<br>10<br>15<br>20<br>25<br>30 (minutes) | 5       |

**No Paper**

| Functions         | Selectable value                               | Default |
|-------------------|--|---------|
| Notify when error | Occurs<br>Occurs & Fixed                       | Occurs  |
| Notify within     | 0<br>5<br>10<br>15<br>20<br>25<br>30 (minutes) | 5       |

**Paper Misfeed**

| Functions         | Selectable value                               | Default |
|-------------------|--|---------|
| Notify when error | Occurs<br>Occurs & Fixed                       | Occurs  |
| Notify within     | 0<br>5<br>10<br>15<br>20<br>25<br>30 (minutes) | 5       |

**Paper Size Mismatch**

| Functions         | Selectable value         | Default |
|-------------------|--------------------------|---------|
| Notify when error | Occurs<br>Occurs & Fixed | Occurs  |
| Notify within     | 0<br>5<br>10             | 5       |



| Functions | Selectable value               | Default |
|-----------|--------------------------------|---------|
|           | 15<br>20<br>25<br>30 (minutes) |         |

### Paper Type Mismatch

| Functions         | Selectable value                               | Default |
|-------------------|--|---------|
| Notify when error | Occurs<br>Occurs & Fixed                       | Occurs  |
| Notify within     | 0<br>5<br>10<br>15<br>20<br>25<br>30 (minutes) | 5       |

4

### Paper Size and Type Mismatch

| Functions         | Selectable value                               | Default |
|-------------------|--|---------|
| Notify when error | Occurs<br>Occurs & Fixed                       | Occurs  |
| Notify within     | 0<br>5<br>10<br>15<br>20<br>25<br>30 (minutes) | 5       |

**Cover Open**

| Functions         | Selectable value                               | Default |
|-------------------|--|---------|
| Notify when error | Occurs<br>Occurs & Fixed                       | Occurs  |
| Notify within     | 0<br>5<br>10<br>15<br>20<br>25<br>30 (minutes) | 5       |

**Unit/Cartridge Not Set**

| Functions         | Selectable value                               | Default |
|-------------------|--|---------|
| Notify when error | Occurs<br>Occurs & Fixed                       | Occurs  |
| Notify within     | 0<br>5<br>10<br>15<br>20<br>25<br>30 (minutes) | 5       |

**Out of Printable Temperature Range**

| Functions         | Selectable value   | Default |
|-------------------|--------------------|---------|
| Notify when error | Occurs             | Occurs  |
| Notify within     | 0<br>5<br>10<br>15 | 5       |

| Functions | Selectable value         | Default |
|-----------|--------------------------|---------|
|           | 20<br>25<br>30 (minutes) |         |

## Auto E-mail Notification: Counter Notification

### Machine Total

| Functions           | Selectable value  | Default         |
|---------------------|---|-----------------|
| Notification Method | Number of Pages<br>Number of Pages & Monthly            | Number of Pages |
| Notify Every        | 100<br>200<br>300<br>400<br>500<br>1000<br>2000 (pages) | 100 (pages)     |
| Notification Day    | 1-28 (days)   | 1 (day)         |

4

## About the Web Browser Help

Using "Settings", you can view help on the things you can do through the Web browser.

1. Launch the Web browser.
2. In the address bar, enter "http://(printer's IP address or host name)/".
3. Click .

Help on the things you can do through the Web browser appears.

## SNMP

The Ethernet interface includes the Simple Network Management Protocol (SNMP) agent for UDP.

Using the SNMP manager, you can obtain printer data.

The default community name is "public". Using this community name, you can obtain MIB data.

### Supporting MIB (SNMP v1/v2c)

- MIB-II
- PrinterMIB
- HostResourceMIB
- RicohPrivateMIB
- PrinterPortMonitorMIB

# 5. Using the Printer with a Macintosh

## System Requirements for Macintosh

### Operating System (for Macintosh)

- PowerPC-Based Macintosh: Mac OS X 10.3 or later
- Intel-Based Macintosh: Mac OS X 10.4.5 or later

**Note**

- The operating environment for the printer driver depends on the application in use.
- OS X Server is not supported.
- Printing with USB 2.0 is supported under Mac OS X 10.3.3 and later versions.

### Hardware (for Macintosh)

#### PowerPC-Based Macintosh

Computer: Macintoshes Based on PowerPC G3 or later PowerPC models

Memory: 128 MB or more

HDD: 50 MB or more

Other requirements: USB port or network port

#### Intel-Based Macintosh

Computer: Macintoshes Based on Intel Core Duo or later Intel models

Memory: 256 MB or more

HDD: 50 MB or more

Other requirements: USB port or network port

**Note**

- You can only use a network printer via a TCP/IP connection. You cannot use AppleTalk.
- This machine does not support Bonjour or Rendezvous connections.

## Preparing for Printing (for Macintosh)

For details about preparing to print from a Macintosh computer, see the following sections:

### **Checking the printer status and settings using the printer's control panel**

See p.65 "Checking the Printer Status and Settings using the Printer's Control Panel (List/Test Print Menu)"

### **Specifying the interface and network settings using the printer's control panel**

See p.73 "Specifying the Interface and Network Settings using the Printer's Control Panel (Host Interface Menu)"

### **Available paper types and how to load paper**

See p.84 "Paper"

### **Loading paper into the paper tray**

See p.44 "Loading Paper"

### **Specifying the paper settings using the printer's control panel**

See p.94 "Specifying the Paper Settings using the Printer's Control Panel (Paper Input Menu)"

# Installing the Printer Driver under Mac OS X

This section explains how to install the printer driver. After installing the printer driver, adjust the settings necessary for printer use.

The following procedures are based on Mac OS 10.5.1. The procedures for your machine might differ slightly from those shown if you are using a different version of Mac OS.

## ★ Important

- Only the English version of the Macintosh printer driver is supplied.

## Installing the Printer Driver on a Macintosh

Follow the procedure below to install the printer driver.

## ★ Important

- You cannot install the printer driver while other applications are running. Be sure to close all applications before installing the printer driver.
- After installing the printer driver, you must restart the computer. Be sure to save any files you are working on before installing the printer driver.
- To install the printer driver, you must log on as administrator. For details, consult the administrator of the Macintosh in question.

1. Start Macintosh, and insert the provided CD-ROM into the CD-ROM drive.
2. In the [RPCS\_R] folder in the [Mac OS X 10.5 or later] folder, double-click the product name.pkg icon.

Under Mac OS X 10.3.x - 10.4.x, double-click the product name.pkg icon in the [RPCS\_R] folder in the [Mac OS X 10.3 or later] folder.



A warning message appears.

3. After reading the displayed message, and then click [Continue].

The following message is displayed: "Welcome to the product name installer"

4. Click [Continue].

The software license agreement appears in the [Software License Agreement] dialog box.

5. After reading the agreement, and then click [Continue].

The confirmation screen appears.

**6. Click [Agree].**

If you click [Disagree], the screen that appeared in the previous step returns.

**7. Click [Install].**

The [Authenticate] dialog box appears.

To select where to install the file, click [Change Install Location...].

Under Mac OS X 10.3.x - 10.4.x, select where to install the file in the [Select a Destination] dialog box,

**8. Enter the administrator's user name and password, and then click [OK].**

The confirmation screen appears.

**9. Read the message on the confirmation screen, and then click [Continue Installation].**

The printer driver is installed.

**10. Click [Restart].**

To complete the installation, the computer restarts.

5

---

## Specifying the Printer Settings on a Macintosh

---

This section explains how to register a printer you want to use in [Printer List]. You can specify usable printers with this registration.

### Using the Printer via a USB Connection from a Macintosh

---

 **Important**

- Connect the printer to the USB port and switch it on in advance.
- Printing with USB 2.0 is supported under Mac OS X 10.3.3 and later versions.

**1. On the [Apple] menu, click [System Preferences...], and then click the [Print & Fax] in the [System Preferences] dialog box.**

The [Print & Fax] appears.

Under Mac OS X 10.3.x - 10.4.x, double-click the Printer Setup Utility icon in the [Utilities] folder in the [Applications] folder.

The [Printer List] appears.

**2. From the list of printers, select a printer that is automatically recognized by plug-and-play, and then delete it. Click [-].**

The confirmation screen appears.

**3. Click [OK].**



**4. Click [+].**

The add printer screen appears.

Under Mac OS X 10.3.x - 10.4.x, click [Add Printer...] on the [Printers] menu or [Add] on the toolbar.

The [Printer Browser] appears.

**5. On the add printer screen, click [Default], and then make sure [Kind] is set to [USB].**

The name of the printer connected to the USB port appears.

Under Mac OS X 10.3.x - 10.4.x, make sure [Connection] is set to [USB].

**6. Select the name of the printer you want to use.****7. Make sure the product name appears in the [Printer Name] field, and then click [Add].****8. If you want to use the bypass tray, tray2 and/or tray 3, select options in the [Installable Options] dialog box, and then select [Continue].****9. The name of the registered printer appears in [Print & Fax].**

Under Mac OS X 10.3.x - 10.4.x, the name of the registered printer appears in [Printer List].

**10. On the [System Preferences] menu, click [Quit System Preferences].**

The [System Preferences] closes.

Under Mac OS X 10.3.x - 10.4.x, click [Quit Printer Setup Utility] on the [Printer Setup Utility] menu.

The [Printer Setup Utility] closes.

**Note**

- If you use a printer that has been automatically recognized by plug-and-play, the driver screens may be displayed in English due to the specifications of the Mac OS X. To display the driver screens properly, delete the printer once from the list of printers.
- To make fine adjustments to print quality, set [Adjust Color Density...] before using the printer.

**Reference**

- For details about setting [Adjust Color Density...], see the printer driver Help.

**Using the Printer via Network Connection from a Macintosh****Important**

- Connect the printer to the network in advance and switch it on.
- Specify the printer's IP address on its control panel in advance.

**1. On the [Apple] menu, click [System Preferences...], and then click the [Print & Fax] in the [System Preferences] dialog box.**

The [Print & Fax] appears.

Under Mac OS X 10.3.x - 10.4.x, double-click the Printer Setup Utility icon in the [Utilities] folder in the [Applications] folder.

The [Printer List] appears.

**2. Click [+].**

The add printer screen appears.

Under Mac OS X 10.3.x - 10.4.x, click [Add Printer...] on the [Printers] menu or [Add] on the toolbar.

The [Printer Browser] appears.

**3. On the add printer screen, click [IP].**

Under Mac OS X 10.3.x - 10.4.x, click [IP Printer] in the [Printer Browser] dialog box.

**4. From the [Protocol] pop-up menu, select [Line Printer Daemon - LPD].**

**5. In the [Address:] field, enter the IP address of the printer you want to use.**

**6. Select [Select a driver to use...] in the [Print Using] field, and then select a printer in the list.**

Under Mac OS X 10.3.x - 10.4.x, select [RICOH] in the [Printer Using] field, and then select a printer in the [Model Name] list.

**7. Click [Add].**

**8. If you want to use the bypass tray, tray2 and/or tray 3, select options in the [Installable Options] dialog box, and then select [Continue].**

**9. The IP address of the registered printer appears in [Print & Fax].**

Under Mac OS X 10.3.x - 10.4.x, the IP address of the registered printer appears in [Printer List].

**10. On the [System Preferences] menu, click [Quit System Preferences].**

The [System Preferences] closes.

Under Mac OS X 10.3.x - 10.4.x, click [Quit Printer Setup Utility] on the [Printer Setup Utility] menu.

The [Printer Setup Utility] closes.

**Note**

- If you use a printer that has been automatically recognized by plug-and-play, the driver screens may be displayed in English due to the specifications of the Mac OS X. To display the driver screens properly, delete the printer once from the list of printers.
- To make fine adjustments to print quality, set [Adjust Color Density...] before using the printer.

**Reference**

- For details about setting [Adjust Color Density...], see the printer driver Help.

# Printer Properties Dialog Box on a Macintosh

This section describes the printer properties dialog box and explains how to open it.

## Dialog Boxes for Printer Settings on a Macintosh

The dialog boxes for specifying the printer driver settings consist of the Page Setup dialog and Print dialog. The printer settings can be adjusted in [Maintenance Utility].

### Page Setup dialog

Specify the paper settings on the Page Setup dialog.

### Print dialog

The Print dialog comprises settings such as [Paper Feed] and [Printer Features].

When you open the Print dialog, the [Copies & Pages] settings appear. Using the pop-up menu in the middle-right of the dialog box, you can switch the displayed settings from [Copies & Pages] to other settings such as [Paper Feed] and [Printer Features].

### Maintenance Utility dialog

Adjust the printer settings in the [Maintenance Utility]. You can open the [Maintenance Utility] from the [Print & Fax].

Under Mac OS X 10.3.x - 10.4.x, you can open the [Maintenance Utility] from the [Printer Setup Utility].

#### ↓ Note

- The way of opening the printer settings differs depending on the application. For details, see the manual provided with the application.
- Under Mac OS X 10.3.x - 10.4.x, the [Copies & Pages] setting appears under the name of the application in use.

#### 📖 Reference

- For details about opening the [Maintenance Utility], see p. 138 "Displaying the [Maintenance Utility] on a Macintosh".

## Displaying the Printer Driver Settings Dialog Boxes on a Macintosh

This section explains how to use the [TextEdit] application provided with Mac OS X.

#### ★ Important

- Under Mac OS X, the printer you want to use must be registered beforehand in [Printer Setup Utility]. After registering the printer, open the printer driver settings dialog box from the application.

### Reference

- For details about specifying the printer driver settings, see p. 133 "Installing the Printer Driver under Mac OS X".

## Displaying the Page Setup dialog on a Macintosh

---

1. From the application's File menu, click [Page Setup...].

The Page Setup dialog appears.

2. From the [Format for] pop-up menu, select the printer you want to use.

If you want to use a printer connected to the network, select the printer according to its IP address.

## Displaying the Print dialog on a Macintosh

---

5

1. From the application's File menu, select [Print...].

The [Copies & Pages] setting appears.

2. From the [Printer] pop-up menu, select the printer you want to use.

If you want to use a printer connected to the network, select the printer according to its IP address.

To display the [Setup] settings, using the pop-up menu in the middle-right of the dialog box, switch from [the name of the application in use] to [Printer Features], and then select [Setup] from the [Feature Sets:] pop-up menu.

To display the [Paper Feed] settings, using the pop-up menu in the middle-right of the dialog box, switch from [the name of the application in use] to [Paper Feed].

Under Mac OS X 10.3.x - 10.4.x, if you open the printer driver settings from an application, the previously specified settings appear. Change the settings as required, and then print.

### Note

- Depending on the application, the printer driver settings may be automatically changed.
- Under Mac OS X 10.3.x - 10.4.x, the [Copies & Pages] setting appears under the name of the application in use.

## Displaying the [Maintenance Utility] on a Macintosh

---

1. On the [Apple] menu, click [System Preferences...], and then click the [Print & Fax] in the [System Preferences] dialog box.

The [Print & Fax] appears.

Under Mac OS X 10.3.x - 10.4.x, double-click the Printer Setup Utility icon in the [Utilities] folder in the [Applications] folder.

The [Printer List] appears.

- 2. From the [Print & Fax], select the printer you want to use, and then click [Open Print Queue...].**

If you want to use a network printer, select it according to its name of the printer.

- 3. On the [Print & Fax] toolbar, click [Utility].**

The [Maintenance Utility] appears.

# Printing with a Macintosh

This section explains how to start and stop printing.

---

## Basic Printing Procedure for Macintosh

---

This section explains the basic procedure for printing from an application.

### Printing on a Macintosh

---

#### ★ Important

- Install the printer driver and configure the printer settings in advance.

5

1. In the application, open the file you want to print.
2. Open the Page Setup dialog, select a printer from the [Format for] pop-up menu, and then specify the paper settings as required.

Be sure to select the actual printer you want to use; do not select "Any Printer". If you do select "Any Printer", you may not be able to access all the paper sizes available on the printer.

3. Open the Print dialog, select a printer from the [Printer] pop-up menu, and then specify the printer settings as required.
4. Click [Print].

Printing starts.

#### ↓ Note

- You can let other Macintoshes on the same network as yours share the printer, whether it is connected to your computer via USB or the network. For details about how to share the printer, see Mac Help.

#### 📖 Reference

- For details about displaying the printer driver settings, see p. 137 "Displaying the Printer Driver Settings Dialog Boxes on a Macintosh".
- For details about specifying the printer driver settings, see p. 133 "Installing the Printer Driver under Mac OS X".
- For details about displaying Mac Help, see p. 149 "Opening Help on a Macintosh".

---

## Printing on Various Paper Types with a Macintosh

---

The print method differs depending on the type of paper used for printing. Use a print method appropriate for each paper type.

## Printing on Paper in a Paper Tray with a Macintosh

This section explains how to load paper in the paper tray and print on it.

### ★ Important

- Curled paper may jam. Straighten any curls before loading.
- Load paper with the print side face down in the paper trays.
- Printing on Envelopes
  - Before loading envelopes, make sure their edges are sharply creased by rubbing them with a pen or similar object.
  - Switch the envelope selector to "✍️".
  - Squeeze the paper guide release, and then slide the paper guides into position according to the envelope size.

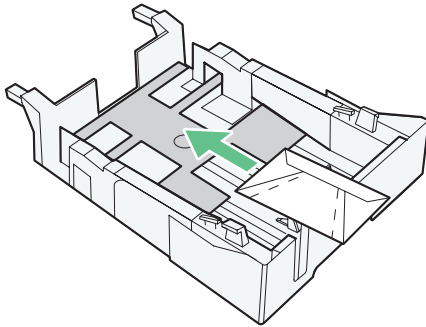

BPR133S

5

### 1. Load paper into tray.

How to load paper depends on the paper type.

### 2. Open the Print dialog.

### 3. Select the tray from the [Paper Feed] settings.

To display the [Paper Feed] settings, using the pop-up menu in the middle-right of the dialog box, switch from [the name of the application in use] to [Paper Feed].

Under Mac OS X 10.3.x - 10.4.x, using the pop-up menu, switch from [Copies & Pages] to [Paper Feed].

### 4. Select the color mode, paper type, and print quality from the [Setup] settings.

Select the color mode from the [Color/Black and White:] pop-up menu, then select the paper type from the [Paper type:] pop-up menu, and then select the print quality from the [Resolution:] pop-up menu.

Under Mac OS X 10.3.x - 10.4.x, select the color mode from the [Color Mode:] pop-up menu, and then select the paper type and print quality from the [Print Mode:] pop-up menu.

To display the [Setup] settings, using the pop-up menu in the middle-right of the dialog box, switch from [the name of the application in use] to [Printer Features], and then select [Setup] from the [Feature Sets:] pop-up menu.

After selecting the paper type as required, switch the envelope selector to "".

If you select [Inkjet Plain Paper], the machine will print on one side only. To print on both sides, select [Plain].

#### 5. Make print settings, and then click [Print].

Depending on the selected paper type, a confirmation screen might appear. If it does, read the message, and then click [OK].

#### Note

- Under Mac OS X 10.3.x - 10.4.x, the [Copies & Pages] setting appears under the name of the application in use.
- The vertical and horizontal resolutions will be the same.

#### Reference

- For details about opening the [Setup] or [Paper Feed] settings, see p.138 "Displaying the Print dialog on a Macintosh".
- For details about the number of sheets that can be loaded in the paper tray, see p.44 "Loading Paper".
- For details about how to handle paper, carry out duplex printing, and use options, see p.44 "Loading Paper".
- For details about dithering, see the printer driver Help.
- For details about specifying a time for ink drying, see the printer driver Help.
- For details about the printable areas of envelopes, see p.44 "Loading Paper".

### Printing with Tray 2/Tray 3 with a Macintosh

---

This section explains how to load paper in tray 2/tray 3 and print on it.

#### Important

- Paper lighter than 157 g/m<sup>2</sup> (297.6 lb.) can be loaded into tray 1. To use Paper lighter than that, click [Plain] in the [Paper type:] pop-up menu.

1. Open the [Setup] settings.
2. Select the paper type from the [Setup] settings.
3. Make sure [Tray 2]/[Tray 3] is selected from the [Paper Feed] settings.
4. Slide the paper guide into position according to the paper size.



**5. Insert a sheet of paper into tray 2/tray 3 with the print side face down.**

Insert the sheet straight into tray 2/tray 3.

**6. Make print settings, and then click [Print].****Note**

- To use tray 2/tray 3, click the [Driver] tab in the [Printer Info] dialog box, and then select the [Tray 2]/[Tray 3] from the pop-up menu. To display the [Printer Info] dialog box, display the [Print & Fax], double-click the printer from the printer list, and then click [Info] on the toolbar.
- Under Mac OS X 10.3.x - 10.4.x, to use tray 2/tray 3, select the [Installable Options] in the [Printer Info] dialog box, and then select options. To display the [Printer Info] dialog box, display the [Printer List], and then click [Show Info] on the [Printers] menu.

**Reference**

- For details about opening the [Setup] or [Paper Feed] setting, see p.138 "Displaying the Print dialog on a Macintosh".
- For details about handling paper, see p.44 "Loading Paper".
- For details about the number of sheets that can be loaded in tray 2/tray 3, see p.44 "Loading Paper".

**Printing with the Bypass Tray with a Macintosh**

This section explains how to load paper in the bypass tray and print on it.

The procedure for loading thick paper in the bypass tray and printing on it is used as an example.

**★ Important**

- Paper lighter than 157 g/m<sup>2</sup> (297.6 lb.) can be loaded into tray 1. To use Paper lighter than that, click [Plain] in the [Paper type:] pop-up menu.

**1. Open the [Setup] settings.****2. Select the paper type from the [Setup] settings.**

Select [Thick] from the [Paper type:] pop-up menu.

Under Mac OS X 10.3.x - 10.4.x, select [Thick paper-High speed] or [Thick paper-Standard] or [Thick paper-High quality] from the [Print Mode:] pop-up menu.

**3. Make sure [Bypass Tray] is selected from the [Paper Feed] settings.****4. Slide the bypass tray guides into position according to the paper size.****5. Insert a sheet of paper into the bypass tray with the print side face up.**

Insert the sheet straight into the bypass tray.

**6. Make print settings, and then click [Print].**

### ↓ Note

- To use the bypass tray, click the [Driver] tab in the [Printer Info] dialog box, and then select the [Bypass Tray Unit] check box. To display the [Printer Info] dialog box, display the [Print & Fax], double-click the printer from the printer list, and then click [Info] on the toolbar.
- Under Mac OS X 10.3.x - 10.4.x, to use the bypass tray, select the [Installable Options] in the [Printer Info] dialog box, and then select the [Bypass Tray Unit] check box. To display the [Printer Info] dialog box, display the [Printer List], and then click [Show Info] on the [Printers] menu.

### 📖 Reference

- For details about opening the [Setup] or [Paper Feed] setting, see p.138 "Displaying the Print dialog on a Macintosh".
- For details about handling paper, see p.44 "Loading Paper".
- For details about the number of sheets that can be loaded in the bypass tray, see p.44 "Loading Paper".

## 5

---

## Canceling a Print Job on a Macintosh

---

You can cancel a print job from either the printer or the computer. The procedure for canceling the job depends on whether or not the computer has sent the job to the printer yet.

### If the computer has sent or is sending the print job to the printer

You can cancel the print job from the print job queue window or by pressing the [Job Reset] key on the printer's control panel.

### If the computer has not yet sent the print job to the printer

If you execute the print command, the print job queue window opens and the print job is queued. Using the print job queue window, you can cancel print jobs.

---

## Canceling a Print Job from the Computer (for Macintosh)

---

You can delete a print job before, during, and after its being sent from the computer to the printer.

1. Check that printing has started and the print job queue window opens.
2. In the print job queue window, select the print job you want to cancel.
3. Click [Delete Job] in the [Jobs] menu or [Delete] on the toolbar.

### 📖 Reference

- For details about the print job queue window, see p.147 "Displaying the Printer Status on a Macintosh".

## Canceling Printing Using the [Job Reset] Key of the Printer (for Macintosh)

---

You can cancel a print job while it is being transmitted or printed.

**1. Check that printing has started.**

Not only the print job being printed but also the print jobs in queue will be canceled.

If you press the [Job Reset] key while the printer is receiving print data for a print job (the Data in lamp is blinking), that print job is also canceled.

**2. Press the [Job Reset] key.**

It will take a few moments for printing to stop.

## Monitoring and Configuring the Printer (for Macintosh)

For details about using a Macintosh to obtain a list of the printer's settings, the printer's status, or similar printer information, see the following section:

### **Checking the printer's status or changing the printer's network settings using a Web browser**

See p.114 "Using Web Browser"

# Displaying the Printer Status on a Macintosh

Using the Status Monitor, you can display the amount of ink left and other printer status details on the computer. You can also check any errors that occur in the print job queue window.

The print job queue window opens automatically when you execute a print command. Using the Status Monitor, you can also display the printer status without executing a print command.

To view the printer's status on your computer, bidirectional communication between the printer and computer must be established.

## Checking whether Bidirectional Communication is Working on a Macintosh

You can view the printer's status on your computer only if the printer and computer are communicating bidirectionally.

Use the following procedure to check whether the computer and printer are communicating bidirectionally.

5

1. **Open [Maintenance Utility].**
2. **Check that [Maintenance Utility] is displayed.**

If [Maintenance Utility] is displayed, bidirectional communication is available.

The printer's status can be checked from the computer if bidirectional communication is available.

### Reference

- For details about displaying the [Print & Fax], see p.138 "Displaying the Print dialog on a Macintosh".
- For details about opening the [Maintenance Utility], see p.138 "Displaying the [Maintenance Utility] on a Macintosh".

## Displaying the Status Monitor on a Macintosh

This section explains how to display the Status Monitor.

1. **Display the [Print & Fax].**  
Under Mac OS X 10.3.x - 10.4.x, display the [Printer List].
2. **From the [Print & Fax], select the printer you want to use.**  
If you want to use a network printer, select it according to its IP address.
3. **On the [Print & Fax] toolbar, click [Utility].**  
The [Maintenance Utility] appears.
4. **Click [Status Monitor].**  
The Status Monitor is launched.

### Reference

- For details about displaying the [Print & Fax], see p.138 "Displaying the Print dialog on a Macintosh".

# Opening Help on a Macintosh

Help is useful for learning about what the various settings do and how to specify them. Use the following procedure to open the printer driver Help and Mac Help under Mac OS X.

---

## Displaying Help from the Print dialog on a Macintosh

---

You can display Help from the Print dialog.

1. **Click the Finder icon on the dock.**
2. **Start Help Viewer from Mac Help, click [Home], and then select [RICOH RPCS Raster Help].**

The Help screen appears.

Under Mac OS X 10.3.x - 10.4.x, start Help Viewer from Mac Help, and then select [RICOH RPCS Raster Help] from the [Library] menu.

### Reference

- For details about displaying the [Setup] or [Paper Feed] settings, see p. 138 "Displaying the Print dialog on a Macintosh".

---

## Displaying Mac Help

---

This section explains how to open Mac Help.

1. **Click the Finder icon on the dock.**
2. **From the [Help] menu, select [Mac Help].**

The Help Viewer is launched and Mac Help appears.

# Maintaining (for Macintosh)

For details about maintaining and managing the printer with a Macintosh computer, see the following sections:

## **Checking the number of printed pages using the control panel**

See p.157 "Checking the Number of Printed Pages using the Control Panel (Counter Menu)"

## **Performing maintenance using the control panel**

See p.159 "Performing Maintenance using the Control Panel (Maintenance Menu)"

## **Specifying system settings using the control panel**

See p.178 "Specifying System Settings using the Control Panel (System Menu)"

## **Selecting the control panel language**

See p.106 "Selecting the Printer Driver Language"

5

## **Restricting printer functions**

See p.189 "Restricting Printer Functions"

## **Replacing a print cartridge**

See p.191 "Replacing a Print Cartridge"

## **Replacing an ink collector unit**

See p.197 "Replacing an Ink Collector Unit"

## **Cleaning**

See p.200 "Cleaning"

## **Moving**

See p.201 "Moving"

## **Disposing**

See p.203 "Disposing"

## **When not using for a long period of time**

See p.204 "When Not Using for a Long Period of Time"



# Troubleshooting (for Macintosh)

## Printing will not start

See p.213 "Printing Will Not Start"

## Paper is not fed or delivered normally

See p.215 "Paper Is Not Fed or Delivered Normally"

## Paper jam

See p.217 "Paper Jam"

## Print results are not satisfactory

See p.241 "Print Results Are Not Satisfactory"

## Error & status messages on the control panel

See p.248 "Error & Status Messages on the Control Panel"

### ↓ Note

- If the custom size setting exceeds the acceptable range, the image will be printed on the OS-specified default paper size. Check the custom size setting range.

# Updating the Printer Driver on a Macintosh

---

## Checking the Version of the Printer Driver on a Macintosh

---

This section explains how to check the version of the current printer driver.

**1. Display the [Print & Fax].**

Under Mac OS X 10.3.x - 10.4.x, Display the [Printer List].

**2. Select the printer you want to use from the printer list, and then click [Info] on the toolbar.**

Under Mac OS X 10.3.x - 10.4.x, click [Show Info] on the [Printers] menu.

The [Printer Info] dialog box opens.

**3. Check the displayed version number.**

**Reference**

- For details about displaying the [Print & Fax], see p.138 "Displaying the Print dialog on a Macintosh".

5

---

## Uninstalling the Printer Driver from a Macintosh

---

To update the printer driver, you need to uninstall the current printer driver and then install the new one.

**★ Important**

- The printer driver cannot be uninstalled if other applications are running. We recommend you close all applications before attempting to uninstall the driver.
- To uninstall a printer driver, you must log on as administrator. For details, consult the administrator of the Macintosh in question.
- When you uninstall a printer driver, the Status Monitor installed with the driver is also uninstalled.

**1. On the [Apple] menu, click [System Preferences...], and then click the [Print & Fax] in the [System Preferences] dialog box.**

The [Print & Fax] appears.

Under Mac OS X 10.3.x - 10.4.x, double-click the Printer Setup Utility icon in the [Utilities] folder in the [Applications] folder.

The [Printer List] appears.

**2. Select the printer you want to delete, and then click [-].**

The confirmation screen appears.

Under Mac OS X 10.3.x - 10.4.x, select the printer you want to delete in the [Printer List], and then click [Delete Selected Printers] in the [Printers] menu, or click [Delete] on the toolbar.

The printer is deleted from [Printer List].

**3. Click [OK].**

The printer is deleted from [Print & Fax].

**4. Click [Quit System Preferences] on the [System Preferences] menu.**

The [System Preferences] closes.

Under Mac OS X 10.3.x - 10.4.x, click [Quit Printer Setup Utility] on the [Printer Setup Utility] menu.

The [Printer Setup Utility] closes.

**5. Insert the provided CD-ROM into the CD-ROM drive.**

**6. In the [RPCS\_R] folder in the [Mac OS X 10.5 or later] folder, double-click the Uninstall\_product name icon.**

Under Mac OS X 10.3.x - 10.4.x, double-click the Uninstall\_product name icon in the [RPCS\_R] folder in the [Mac OS X 10.3 or later] folder.



The confirmation screen appears.

**7. Click [OK].**

A dialog box for entering the user name and password opens.

If you click [Cancel], the installation dialog box closes and the printer driver is not uninstalled.

**8. Enter the administrator's user name and password, and then click [OK].**

A message confirming that the uninstallation is complete appears.

**9. Click [OK].**

**Reference**

- For details about checking the printer driver version, see p. 152 "Checking the Version of the Printer Driver on a Macintosh".

# Software on the CD-ROM for Macintosh

This section describes the CD-ROM supplied with the printer.

## Files for Macintosh

The following is a list of the files on the CD-ROM.

| File Name  |
|--|
| product name_Mac_OS_X  |
| RPCS Raster Printer Driver for Macintosh <ul style="list-style-type: none"><li>• PowerPC-Based Macintosh: Mac OS X 10.3 or later</li><li>• Intel-Based Macintosh: Mac OS X 10.4.5 or later</li></ul> |
| Manuals (HTML files)   |

5

## RPCS Raster Printer Drivers for Macintosh

This section gives the file locations of the different RPCS raster printer drivers and their system requirements.

### File Location

The drivers are in the following folders on the supplied CD-ROM.

- RPCS raster printer driver for Mac OS X 10.3 or later  
**Mac OS X 10.3 or later\RPCS\_R**
- RPCS raster printer driver for Mac OS X 10.5 or later  
**Mac OS X 10.5 or later\RPCS\_R**

### System Requirements for the Printer Drivers

- Computer  
PowerPC-Based Macintosh/Intel-Based Macintosh
- Operating Systems  
PowerPC-Based Macintosh: Mac OS X 10.3 or later  
Intel-Based Macintosh: Mac OS X 10.4.5 or later
- Display Resolution  
Minimum SVGA 800 × 600 pixels

 **Note**

- For details about using the printer driver, see the printer driver Help.

---

## **Manuals (HTML files) for Macintosh**

---

This section gives the location of the manuals.

### **File Location**

The manuals are in the following folders on the supplied CD-ROM.

MANUAL\_HTML\LIST



# 6. Maintaining

---

## Checking the Number of Printed Pages using the Control Panel (Counter Menu)

You can check and print out the printer's counter figures.

Counters show the number of prints made by the printer. Print counter numbers do not include test patterns printed using "Maintenance", system configurations printed using "List/Test Print", and counter printouts made using "Counter".

### Show Counter

- Color:  
This counter shows the total number of pages printed in color.
- Black:  
This counter shows the total number of pages printed in black and white.
- EconClr:  
This counter shows the total number of pages printed in Economy Color.

### Print

You can print out the printer's page counts, including the number of duplex-printed pages.

"Total Mono+Economy Color" combines "Total Mono Color" and "Total Economy Color".

#### Note

- Black and white files are counted as black and white prints even if color printing was specified.

---

## Displaying the Counter

---

You can display the counter.

1. Press the [Menu] key.

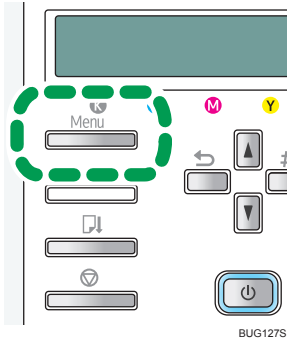

2. Press [▲] or [▼] to display [Counter], and then press the [#Enter] key.

```
Menu:
Counter
```

3. Press [▲] or [▼] to display [Show Counter], and then press the [#Enter] key.

```
Menu:
Show Counter
```

4. Press [▲] or [▼], and then check the [Color], [Black], and [EconClr] on the display.

```
Color: 12345678
Black: 12345678
```

```
EconClr: 12345678
```

5. Press the [Online] key.

The operating screen appears.



# Performing Maintenance using the Control Panel (Maintenance Menu)

Using the Maintenance menu, you can specify printer maintenance settings for adjusting settings such as gradation and density.

## Nozzle Check

You can print a test pattern to check whether the inks are being correctly ejected from the print head nozzles.

## Head-cleaning

You can clean the print head.

Clean the head if certain colors are not printed or are printed faintly.

Head cleaning consumes ink.

## Head-flushing

You can clean the print head more thoroughly.

Because head flushing consumes more ink than head cleaning, do it only if the print head cannot be cleaned properly by head cleaning.

## Head Position

If bidirectionally printed lines are vertically misaligned, or if printed images are blurred, print the test pattern and adjust the print head alignment.

## Adj.Paper Feed

If printed lines are horizontally misaligned or if images are printed unevenly, print the test pattern and adjust the paper feed setting.

## Registration

Print the test pattern and align the point where printing starts for each paper feed tray.

## Date/Time

You can specify the date and time.

## Key Repeat

The key repeat function allows you to specify setting values in units of ten or scroll the display quickly by pressing and holding down a control panel key. You can enable or disable this function.

- On
- Off

Default: On

## Dry-delay (Exit)

To prevent spoiling of printed copies, select a print delivery interval to allow them to dry.

The interval must be long enough to allow a sheet to dry.

- Off
- 1 sec
- 2 sec
- 5 sec
- 10 sec
- 15 sec
- 20 sec

Default: Off

### **Dry-delay (Dup)**

To prevent spoiling of duplex-printed copies, select a print delivery interval to allow them to dry.

The interval must be long enough to allow a duplex-printed sheet to dry.

- Off
- 1 sec
- 2 sec
- 5 sec
- 10 sec
- 15 sec
- 20 sec

Default: Off

### **Paper Feed Test**

You can eject a sheet of paper without printing anything on it.

### **De-condensation**

To remove moisture from inside the printer, you can eject three sheets of paper without printing anything on them.

---

## **Nozzle Check**

---

Follow the procedure below to check whether the print-head nozzles are clogged up or not by printing a nozzle check test pattern.

**1. Press the [Menu] key.**

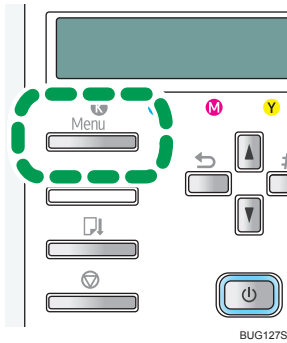

**2. Press the [▲] or [▼] key to display [Maintenance], and then press the [#Enter] key.**

Menu:  
Maintenance

**3. Press the [▲] or [▼] key to display [Nozzle Check], and then press the [#Enter] key.**

Maintenance:  
Nozzle Check

**4. Press the [#Enter] key.**

Press # to  
print pattern

A test pattern is printed.

**5. Press the [Online] key.**

The initial screen appears.

**6. Check the printed test pattern.**

Normal

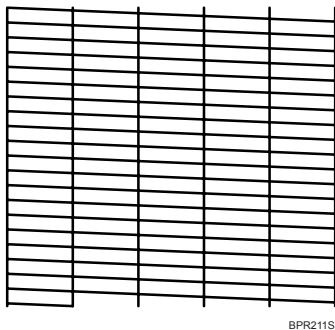

When print-heads are clogged

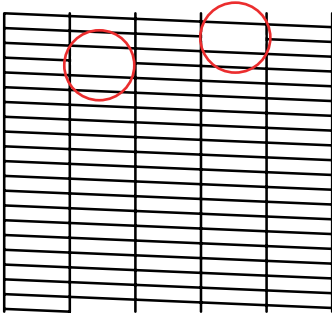

BPR212S

## Head-cleaning

Follow the procedure below to perform a normal print-head cleaning. Perform a head cleaning when a particular color cannot be printed or print images are blurred. Head cleaning consumes ink.

When the Print cartridge is empty, replace it instead of performing a print-head cleaning. After a Print cartridge is replaced, a print-head cleaning will be automatically performed.

6

1. Slide the envelope selector  to the forward position.

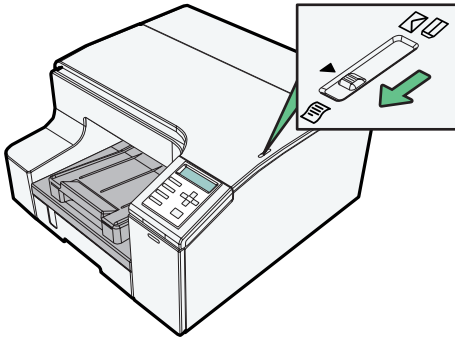

BUG137S

2. Press the [Menu] key.

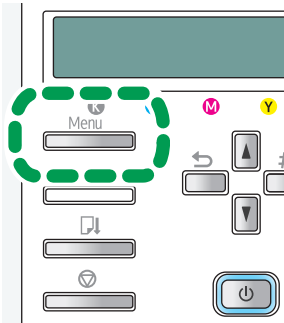

BUG127S

3. Press the [▲] or [▼] key to display [Maintenance], and then press the [#Enter] key.

Menu:  
Maintenance

4. Press the [▲] or [▼] key to display [Head-cleaning], and then press the [#Enter] key.

Maintenance:  
Head-cleaning

5. Press the [▲] or [▼] key to select a color, and then press the [#Enter] key.

Head-cleaning:  
All Heads

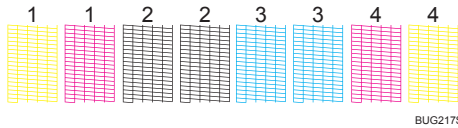

1. Head 1 (Yellow/Magenta)
2. Head 2 (Black)
3. Head 3 (Cyan)
4. Head 4 (Magenta/Yellow)

6. Press the [#Enter] key.

Press # to  
clean heads

Head cleaning starts.

Maintenance  
in process...

7. Press the [Online] key.

The initial screen appears.

## No-Fuss Head Cleaning

When the machine is online, you can clean the cyan, magenta, yellow, and black print heads with just a couple of keystrokes.

-22, -27

1. Press the [▼] key.

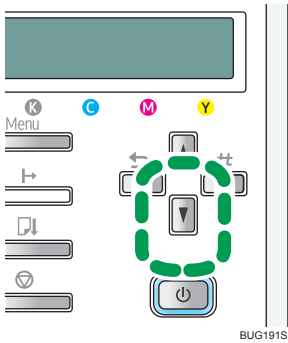

The following message appears:

Press # to  
clean heads

2. Press the [#Enter] key.

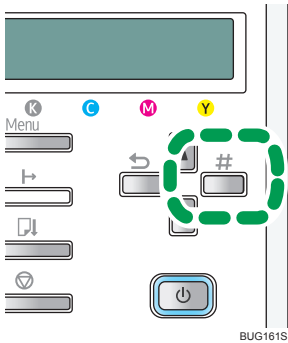

Head cleaning starts.

-17

1. Hold the [Form Feed] key down for 3 seconds.

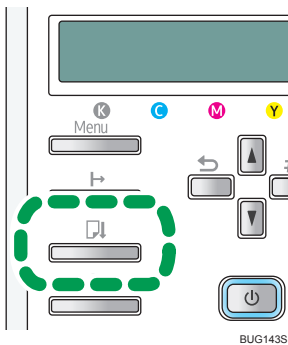

Head cleaning starts.

## Head-flushing

Follow the procedure below to perform a thorough print-head cleaning. Since this consumes more ink than a normal head cleaning does, perform this when the problem persists after performing a normal head cleaning.

When the Print cartridge is empty, replace it instead of performing a print-head cleaning. After a Print cartridge is replaced, a print-head cleaning will be automatically performed.

1. Slide the envelope selector  to the forward position.

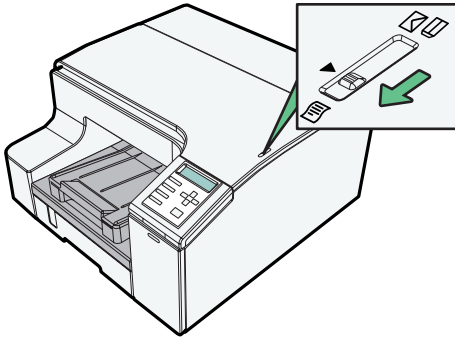

BUG137S

2. Press the [Menu] key.

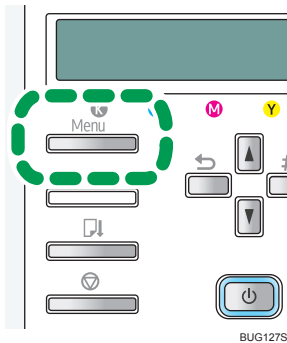

BUG127S

3. Press the [▲] or [▼] key to display [Maintenance], and then press the [#Enter] key.

```
Menu:
Maintenance
```

4. Press the [▲] or [▼] key to display [Head-flushing], and then press the [#Enter] key.

```
Maintenance:
Head-flushing
```

5. Press the [▲] or [▼] key to select a color, and then press the [#Enter] key.

```
Head-flushing:
All Heads
```

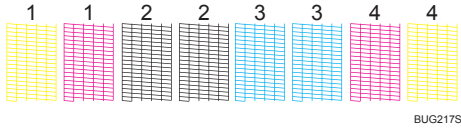

1. Head 1 (Yellow/Magenta)
2. Head 2 (Black)
3. Head 3 (Cyan)
4. Head 4 (Magenta/Yellow)

**6. Press the [#Enter] key.**

Press # to  
flush heads

Head flushing starts.

Maintenance  
in process...

**6**

**7. Press the [Online] key.**

The initial screen appears.

---

## Head Position

---

Follow the procedure below to print a test pattern and adjust the print-head positions if vertical lines are printed unaligned or printed colors look blurred.

1. Slide the envelope selector to  the forward position.

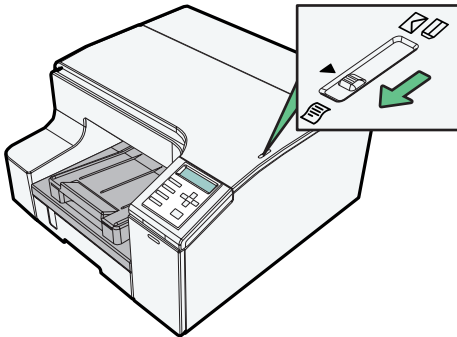

BUG137S



**2. Press the [Menu] key.**

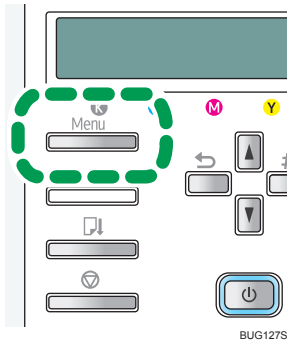

**3. Press the [▲] or [▼] key to display [Maintenance], and then press the [#Enter] key.**

Menu:  
Maintenance

**4. Press the [▲] or [▼] key to display [Head Position], and then press the [#Enter] key.**

Maintenance:  
Head Position

**5. Press the [▲] or [▼] key to display [Pr.Test Pattern], and then press the [#Enter] key.**

Head Position:  
Pr.Test Pattern

**6. Press the [▲] or [▼] key to select a test pattern, and then press the [#Enter] key.**

Pr.Test Pattern:  
High Speed

To adjust print-head positions for all resolutions, repeat this procedure selecting the other resolution.  
A test pattern to adjust print-head positions is printed.

**7. Check the optimal adjustment values on the printed test pattern.**

The optimal adjustment value is the column number above the square that is between the straight vertical lines and that is the lightest shade of gray. If the column number for the "A" line is "+2", the optimal adjustment value is for "A" is "+2".

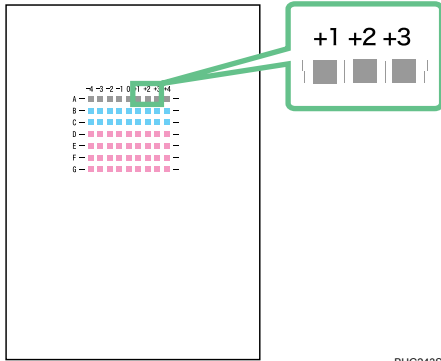

8. Press the [▲] or [▼] key to display [Adjustment], and then press the [#Enter] key.
9. Press the [▲] or [▼] key to select a resolution from step 5, and then press the [#Enter] key.

```
Adjustment:
High Speed
```

10. Press the [▲] or [▼] key to select a line, and then press the [#Enter] key.

```
Adjustment:
1.A
```

11. Enter the optimal adjustment values from step 6, and then press the [#Enter] key.

```
A:
(-4, +4)      0
```

12. Press the [Online] key.

The initial screen appears.

## Adj.Paper Feed

If horizontal lines are printed unaligned, print images are patchy, or a black or white line is printed at regular intervals, print a test pattern, and then adjust the paper feed setting.

1. Slide the envelope selector to  the forward position.

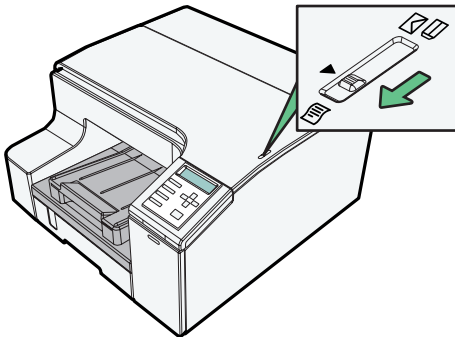

BUG137S

2. Press the [Menu] key.

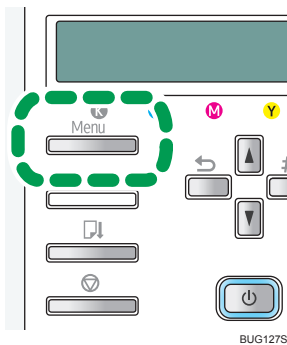

BUG127S

3. Press the [▲] or [▼] key to display [Maintenance], and then press the [#Enter] key.

```
Menu:
Maintenance
```

4. Press the [▲] or [▼] key to display [Adj.Paper Feed], and then press the [#Enter] key.

```
Maintenance:
Adj.Paper Feed
```

5. Press the [▲] or [▼] key to display [Pr.Test Pattern], and then press the [#Enter] key.

```
Adj.Paper Feed:
Pr.Test Pattern
```

A test pattern to adjust paper feed is printed.

6. Check the optimal adjustment values on the printed test pattern.

The optimal adjustment value is the number that appears on the left of the lightest gray square with straight horizontal lines on both sides. When this number is "+2", the optimal adjustment value is "+2".

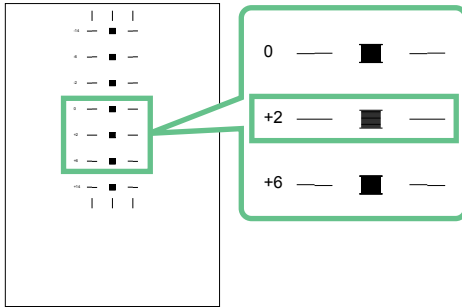

BPR214S

When horizontal lines beside the lightest gray square are broken, select the optimal adjustment value by referring to the lines broken in the opposite direction. When the "+2" square is the lightest gray square and the "+6" horizontal lines are broken in the opposite direction, the optimal adjustment value is between "+3" and "+5". After adjustment, check the adjustment result.

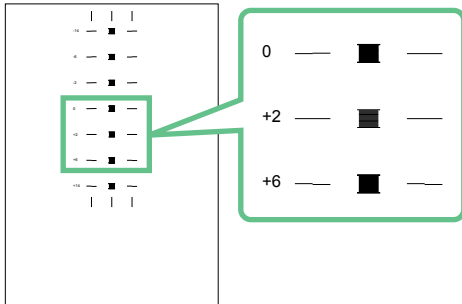

ZKX040J

6

7. Press the [▲] or [▼] key to display [Adjustment], and then press the [#Enter] key.

```
Adj.Paper Feed:
Adjustment
```

8. Press the [▲] or [▼] key to enter the adjustment value (-14 to +14) from step 5, and then press the [#Enter] key.

```
A:
(-14, +14)    0
```

9. Press the [Online] key.

The initial screen appears.

## Registration

Follow the procedure below to adjust where to start printing on paper loaded in each paper tray after checking the test pattern printed.

1. Slide the envelope selector to  the forward position.

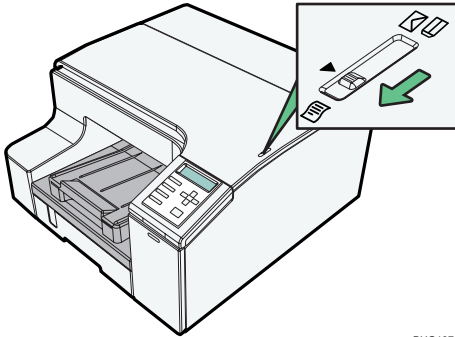

BUG137S

2. Press the [Menu] key.

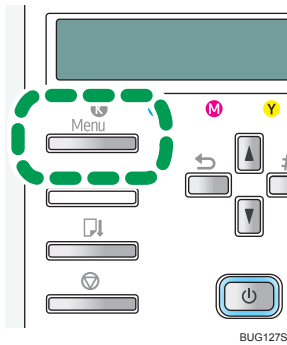

BUG127S

3. Press the [▲] or [▼] key to display [Maintenance], and then press the [#Enter] key.

```
Menu:
Maintenance
```

4. Press the [▲] or [▼] key to display [Registration], and then press the [#Enter] key.

```
Maintenance:
Registration
```

5. Press the [▲] or [▼] key to display [Pr.Test Pattern], and then press the [#Enter] key.

```
Registration:
Pr.Test Pattern
```

6. Press the [▲] or [▼] key to select a paper tray, and then press the [#Enter] key.

```
Pr.Test Pattern:
Tray 1
```

7. Press the [▲] or [▼] key to select a paper type, and then press the [#Enter] key.

```
Pr.Test Pattern:
*Plain Paper
```

A test pattern to adjust the print start position is printed.

8. Check the optimal adjustment values on the printed test pattern.
9. Fold the test pattern sheet in half lengthwise.

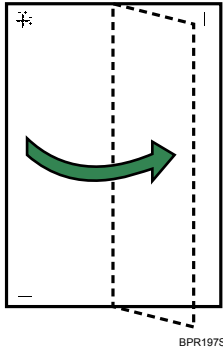

10. The optimal adjustment value is the difference between the single vertical line and the cross's vertical line that you can see when the folded paper is held up to light. When the difference is one calibration mark in the "+" direction, the optimal adjustment value for the [Read Direction] is "+1.0".

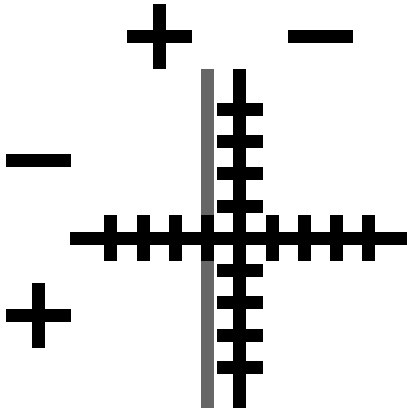

11. Fold the test pattern sheet in half widthwise, and then check the adjustment value for the [Feed Direction]

Adjustment values are in 0.1 increments.

12. Press the [▲] or [▼] key to display [Adjustment], and then press the [#Enter] key.

Registration:  
Adjustment

13. Press the [▲] or [▼] key to select a paper tray, and then press the [#Enter] key.

Adjustment:  
Tray 1

14. Press the [▲] or [▼] key to select a paper type, and then press the [#Enter] key.

```
Adjustment:
*Plain Paper
```

15. Press the [▲] or [▼] key to enter the adjustment values (-4.0 to +4.0) in the [Read Direction] from step 7, and then press the [#Enter] key.

```
Read Direction:
(-4, +4)  0.0
```

16. Press the [▲] or [▼] key to enter the adjustment values (-4.0 to +4.0) in the [Feed Direction] from step 7, and then press the [#Enter] key.

```
Feed Direction:
(-4, +4)  0.0
```

17. Press the [Online] key.

The initial screen appears.

**Note**

- For Tray 2, Tray 3, and the bypass tray, you can adjust [Read Direction] only.
- If you select [Glossy Paper] as the paper type for Tray 1, you can adjust [Feed Direction] only.

## Setting the Date and Time

Use the following procedure to specify the date, time, and time zone.

### Date Setting

1. Press the [Menu] key.

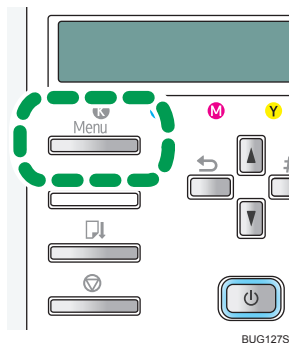

2. Press the [▲] or [▼] key to display [Maintenance], and then press the [#Enter] key.

Menu:  
Maintenance

3. Press the [▲] or [▼] key to display [Date/Time], and then press the [#Enter] key.

Maintenance:  
Date/Time

4. Press the [▲] or [▼] key to display [Date Setting], and then press the [#Enter] key.

Date/Time:  
Date Setting

5. Press the [▲] or [▼] key to set the date, and then press the [#Enter] key.

-22, -27

Date Setting:  
30/ 8/2008

-17

Date Setting:  
8/30/2008

6. Press the [Online] key.

The initial screen appears.

## Time Setting

1. Press the [Menu] key.

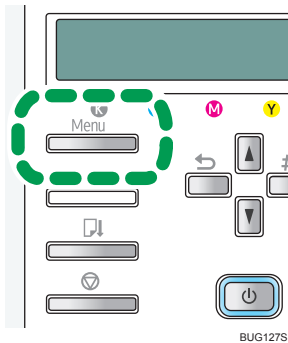



2. Press the [▲] or [▼] key to display [Maintenance], and then press the [#Enter] key.

```
Menu:
Maintenance
```

3. Press the [▲] or [▼] key to display [Date/Time], and then press the [#Enter] key.

```
Maintenance:
Date/Time
```

4. Press the [▲] or [▼] key to display [Time Setting], and then press the [#Enter] key.

```
Date/Time:
Time Setting
```

5. Press the [▲] or [▼] key to set the time, and then press the [#Enter] key.

```
-22, -27
```

```
Time Setting:
10:31:25
```

```
-17
```

```
Time Setting:
10:31:25 AM
```

6. Press the [Online] key.

The initial screen appears.

## Time Zone Setting

1. Press the [Menu] key.

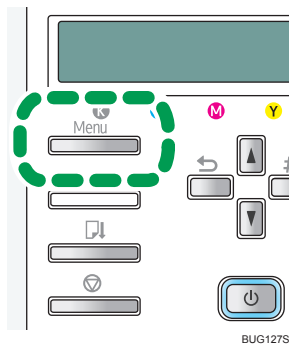

2. Press the [▲] or [▼] key to display [Maintenance], and then press the [#Enter] key.

```
Menu:  
Maintenance
```

3. Press the [▲] or [▼] key to display [Date/Time], and then press the [#Enter] key.

```
Maintenance:  
Date/Time
```

4. Press the [▲] or [▼] key to display [Time Zone], and then press the [#Enter] key.

```
Date/Time:  
Time Zone
```

5. Press the [▲] or [▼] key to set the time zone, and then press the [#Enter] key.

```
Time Zone:  
GMT+09:00
```

6. Press the [Online] key.

The initial screen appears.

6

## De-condensation

If the "ERR (993) Power Off On / Call Service if error reoccurs" message appears, there might be condensation inside the printer. You can dry the printer's interior by performing the de-condensation procedure.

1. Press the [Menu] key.

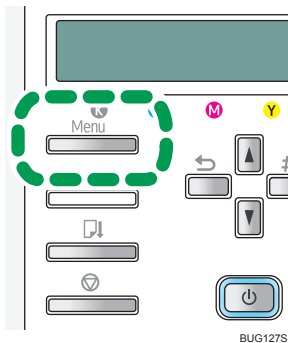

2. Press the [▲] or [▼] key to display [Maintenance], and then press the [#Enter] key.

```
Menu:  
Maintenance
```

3. Press the [▲] or [▼] key to display [De-condensation], and then press the [#Enter] key.

Maintenance:  
De-condensation

Three sheets are fed through the printer without anything being printed on them.

4. Switch the printer off and then back on again.

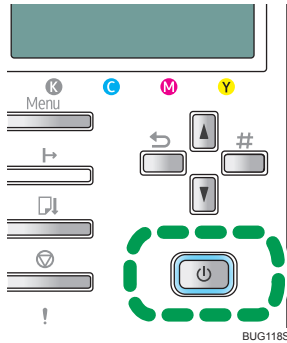

If the error message does not reappear, the printer's interior has fully dried.

If the error persists, switch the printer off, leave it for an hour, and switch it back on. If this does not solve the problem, contact your sales or service representative.

↓ **Note**

- If the paper is smeared with ink after being ejected, contact your sales or service representative.

📖 **Reference**

- p.316 "Where to Inquire"

# Specifying System Settings using the Control Panel (System Menu)

You can set basic functions required to use the printer. The printer can be used on factory default, but the configuration can be changed depending on the condition of the user. The changed condition holds even if the printer is turned off.

## **Prt. Err Report**

Select this to have an error report printed when a printer or memory error occurs.

- Off
- On

Default: Off

## **Auto Continue**

You can specify how the printer handles a print job if it does not have a tray containing paper of the size and type specified in the printer driver.

- Off

The printer does not print until a tray containing paper of the size and type required for the print job is inserted.

- Immediate

The printer prints even if the paper size or paper type is different from that specified.

Default: Immediate

## **Sub Paper Size**

You can specify whether to print on A4 paper if the printer is not equipped with a paper tray that can feed Letter (8 1/2×11) paper specified on the printer driver, and vice versa.

- Auto
- Off

Default: Off

## **Energy Saver**

Use Energy Saver mode to reduce the printer's power consumption.

You can specify how long the printer remains idle before it switches to Energy Saver mode. When the printer is in Energy Saver mode, it requires time to start up when it receives a print job.

- 5 minutes
- 15 minutes
- 30 minutes
- 45 minutes

- 60 minutes

Default: 5 minutes

### Notify by Email

You can specify whether or not to send notification that a printer error has occurred to a particular e-mail address.

After changing this setting, turn the printer off and then back on.

- Off
- On

Default: Off

### Memory Usage

Insufficient memory can cause printing to fail or a file's image data to not be printed. If this happens, you can specify the priority assigned to the printer's memory space.

- Font Priority  
Select this if a file's image data is not printed.
- Frame Priority  
Select this if printing fails due to insufficient memory.

Default: Frame Priority

### Unit of Measure

You can switch the measurement between "mm" and "inch".

- mm
- inch

: Default: mm

: Default: inch

### Page Size

You can select the default paper size.

- A4 (210×297)
- B5 JIS (182×257)
- A5 (210×148)
- A6 (105×148)
- 8 1/2×14
- 8 1/2×11
- 8 1/2×5 1/2
- 7 1/4×10 1/2
- 8×13

- 8 1/2×13
- 8 1/4×13
- 16K (195×267)
- 4 1/8×9 1/2
- 3 7/8×7 1/2
- C5 Env (162×229)
- C6 Env (114×162)
- DL Env (110×220)
- Custom Size

Default: A4 (210×297)

### Paper Type

You can select the default paper type.

- Plain Paper
- Inkjet Plain Paper
- Glossy Paper
- Inkjet Postcard
- Postcard
- Envelope
- Thick Paper

Default: Plain Paper

### Preprinted Ppr

You can enable this to print on pre-printed or pre-punched paper.

- Off
- On

Default: Off

### Copies

Specify the number of pages to print.

This setting is disabled if the number of pages to print is specified by the printer driver.

- 1-999

### Duplex

Specify whether or not to print on both sides of a sheet.

- Off
- Short Edge Bind

- Long Edge Bind

Default: Off

### Blank Pg. Print

Specify whether or not to print blank pages.

- On
- Off

Default: On

### Tray Switching

You can set to switch the paper tray.

- Off
- On

Default: Off

### Uni-direct.Prt.

Specify whether to print unidirectionally or bidirectionally.

Unidirectional printing produces higher quality print, but bidirectional printing is faster.

- Env.Selector:On

Printing is done unidirectionally or bidirectionally according to the envelope selector position.

If the envelope selector is set to the rear position, printing is done unidirectionally.

If the envelope selector is set to the forward position, printing is done unidirectionally or bidirectionally according to the paper type.

- Auto Detect

Printing is done unidirectionally or bidirectionally according to the paper type, regardless of the envelope selector position.

- Always

Printing is always done unidirectionally, regardless of the envelope selector position.

Default: Env.Selector:On

### Density

You can adjust the density of the printing color.

- Light
- Standard
- Dark

-22, -27: Default: Standard

-17: Default: Dark

### Color Mode

You can select the default color mode.

- Color
- Economy Color
- Black and White

Default: Color

### Recycl.Ppr.Mode

You can enable this to print on recycled paper.

- Off
- On

Default: Off

### Env.Slctr.Alert

You can specify whether or not to enable the Env.Slctr.Alert function.

- Display Alert

If you attempt bidirectional printing on sheets when the envelope selector is in the  (rear) position, printing does not begin and an error message notifying you that the envelope selector is incorrectly set will appear.

- No Alert & Prnt

Regardless of the envelope selector position, the printer ignores the error and continues printing.

Default: Display Alert

### Pg Recov. Error

You can specify whether or not Page Recovery Error is reported.

- Display
- Do not Display

Default: Display

### Ink C.U. Space

You can check the remaining capacity of the ink collector unit.

---

## Changing the System Menu

---

This section explains setting Energy Saver mode as an example of how to change a System menu setting.



**1. Press the [Menu] key.**

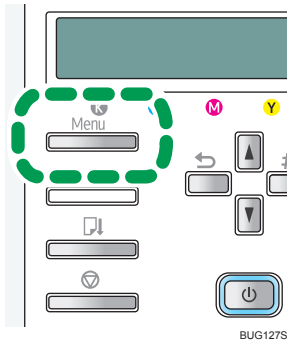

**2. Press [▲] or [▼] key to display [System], and then press the [#Enter] key.**

```
Menu:
System
```

**3. Press [▲] or [▼] key to display [Energy Saver], and then press the [#Enter] key.**

```
System:
Energy Saver
```

**4. Press [▲] or [▼] key to select the lead time needed to switch to the Energy Saver mode.**

```
E.Saver Timer:
*5 minutes
```

**5. Press the [#Enter] key.**

The [System] screen appears.

**6. Press the [Online] key.**

The initial screen appears.

# Specifying PCL Settings using the Control Panel (PCL Menu)

You can set conditions when using PCL for printing.

## Orientation

You can select the page orientation.

- Portrait
- Landscape

Default: Portrait

## Form Lines

You can specify the number of lines per page between 5 and 128.

Default:

- Metric version: 64
- Inch version: 60

## Font Source

You can set the location of the default font.

- Resident
- RAM

Default: Resident

When you select [RAM], you can select only fonts downloaded to the printer RAM.

## Font Number

You can specify the ID of the default font you want to use.

- 0 to 63 (Internal)
- 1 to n (Download)

The value of "n" is the number of fonts downloaded to the printer RAM.

## Point Size

You can specify the point size you want to use for the default font between 4 and 999.75 in 0.25 increments.

Default: 12.00 points

This setting is effective only for a variable-space font.

## Font Pitch

You can specify the number of characters per inch you want to use for the default font between 0.44 and 99.99 in 0.01 increments.

Default: 10.00 pitch

This setting is effective only for fixed-space fonts.

### Symbol Set

You can specify the character set for the default font. Available sets are as follows:

Roman-8, ISO L1, ISO L2, ISO L5, PC-8, PC-8 D/N, PC-850, PC-852, PC8-TK, Win L1, Win L2, Win L5, Desktop, PS Text, VN Intl, VN US, MS Publ, Math-8, PS Math, VN Math, Pifont, Legal, ISO 4, ISO 6, ISO 11, ISO 15, ISO 17, ISO 21, ISO 60, ISO 69, Win 3.0

Default: PC-8

### Courier Font

You can select a courier-type font.

- Regular
- Dark

Default: Regular

### Ext. A4 Width

You can extend the width of the printable area of A4 sheets reducing side margin width.

- On
- Off

Default: Off

### Append CR to LF

You can specify whether or not to append a CR code to each LF code to print text data clearly.

- On
- Off

Default: Off

### Resolution

You can specify the print resolution in dots per inch.

- 600 × 300 dpi
- 600 × 600 dpi
- 300 × 150 dpi

Default: 600 × 300 dpi

### Black Printing

You can select the black printing.

- Use 4 Colors
- Driver Setting

Default: Driver Setting

## Changing the PCL Menu

This section explains setting the symbol set mode as an example of how to change a PCL menu setting.

1. Press the [Menu] key.

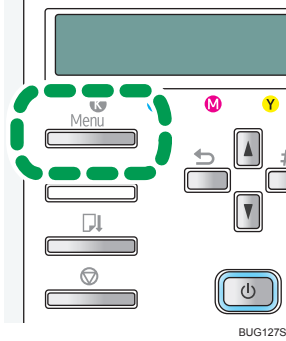

2. Press [▲] or [▼] key to display [PCL Menu], and then press the [#Enter] key.

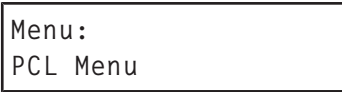

3. Press [▲] or [▼] key to display [Symbol Set], and then press the [#Enter] key.



4. Press [▲] or [▼] key to display [PC-8], and then press the [#Enter] key.

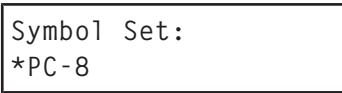

The [PCL Menu] screen appears.

5. Press the [Online] key.

The initial screen appears.

# Selecting the Control Panel Language

This section explains how to select the language used for the settings and messages displayed on the control panel.

1. Press the [Menu] key.

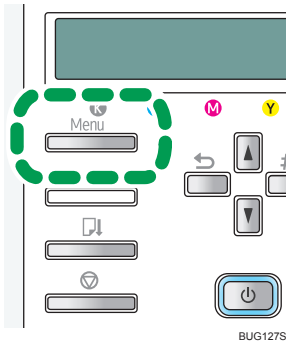

2. Press the [▲] or [▼] key to display [Language], and then press the [#Enter] key.



3. Press the [▲] or [▼] key to select the language, and then press the [#Enter] key.



The message "Power Off On to Change Setting" appears.

4. Switch the printer off and back on.

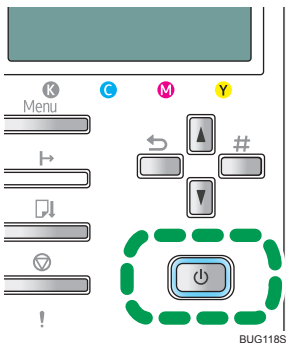

Use the following procedure to change the language setting.

1. Press the [Online] key.

The initial screen appears.

2. Press the [Menu] key.

**3. Press the [▲] key once, and then press the [#Enter] key.**

The Language setting appears.

**4. In the language list (shown below), find the language you require.**

On the printer's control panel, the names of the available languages appear in English.

Language List

| Language Name Displayed on Control Panel (English) | Language                    |
|--|-----------------------------|
| Japanese   | Japanese ([-17] only)       |
| English  | English                     |
| German   | German                      |
| French   | French                      |
| Italian  | Italian                     |
| Dutch  | Dutch                       |
| Swedish  | Swedish                     |
| Norwegian  | Norwegian                   |
| Danish   | Danish                      |
| Spanish  | Spanish                     |
| Finnish  | Finnish                     |
| Portuguese   | Portuguese                  |
| Czech  | Czech ([-22, -27] only)     |
| Polish   | Polish ([-22, -27] only)    |
| Hungarian  | Hungarian ([-22, -27] only) |

**5. Select the language you require, and then press the [#Enter] key.**

**6. Press the [Online] key.**

**7. Switch the printer off and then back on.**

# Restricting Printer Functions

This section explains how to lock keys on the printer's control panel to prevent general users from changing settings and performing certain functions.

By locking certain control panel keys, you can prevent users other than the administrator from doing the following:

- Pressing the [Menu] key to display the menu
- Holding the [Form Feed] key down to clean the print head
- Pressing the [Job Reset] key to cancel print jobs
- Pressing the [Power] key to switch the printer off
- Pressing the [Online] key to switch between online and offline modes

## Locking the Keys

Use this procedure to lock the control panel keys.

1. **Simultaneously hold the [▼], [Escape], and [#Enter] keys down for 3 seconds, and then [#Enter] key.**

The following message appears:

```
Press # to
lock
```

2. **Press the [#Enter] key.**

The following message appears:

```
Panel Locked
```

The initial screen appears.

## Unlocking the Keys

Use this procedure to unlock the control panel keys.

1. **Press the key you want to unlock.**

The following message appears:

```
Panel Locked
Cannot use
```

2. Simultaneously hold the [▼], [Escape], and [#Enter] keys down for 3 seconds, and then [#Enter] key.

The following message appears:

Press # to  
unlock

3. Press the [#Enter] key.

The following message appears:

Panel Unlocked

The initial screen appears.



# Replacing a Print Cartridge

Follow the procedure below to replace a Print cartridge.

## Checking the Remaining Ink

Follow the procedure below to check when to replace Print cartridges using the Status monitor or the cartridge replacement indicators.

### Checking the cartridge replacement indicators of the printer control panel

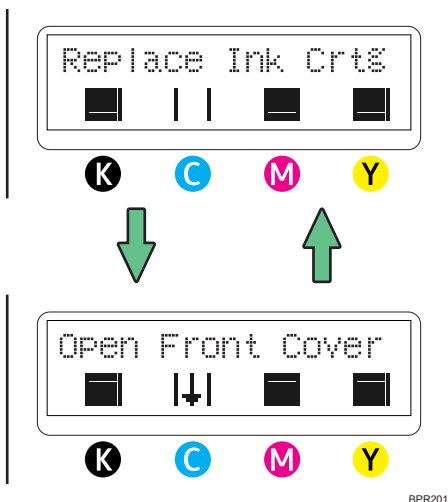

The illustration above indicates the control panel is indicating that the cyan print cartridge is empty.

### Checking Using the Status Monitor

1. Open the printer properties dialog box.
2. Click the [Maintenance] tab.
3. Click [Display Status Monitor].

The Status monitor dialog box appears.

#### 4. Check the cartridge status.

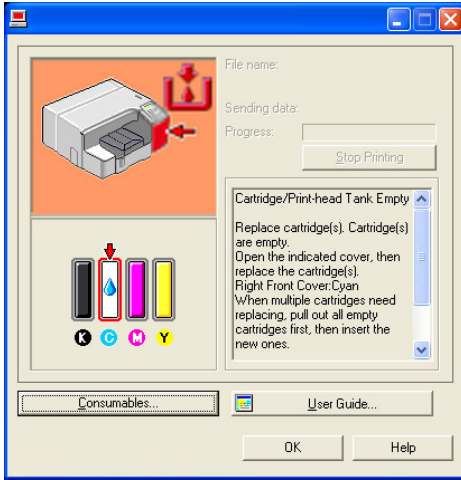

The illustration above indicates the cyan ink has completely run out.

A red background in the image indicates that printing is not possible. Check which color of cartridge needs to be replaced, and then replace it.

From left to right, the cartridge replacement indicators display the status of the black (K), cyan (C), magenta (M), and yellow (Y) Print cartridges.

#### ↓ Note

- The cartridge status can be used for determination of cartridge change.

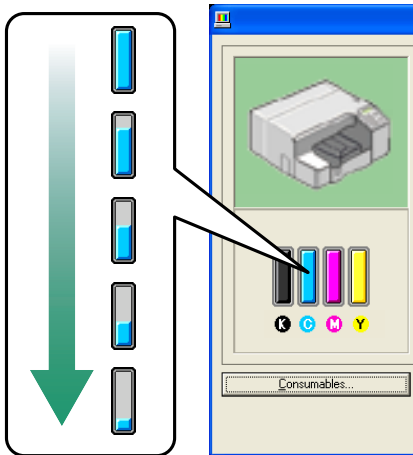

BUG1385

- A message indicating to replace a print cartridge can be also checked on the control panel.

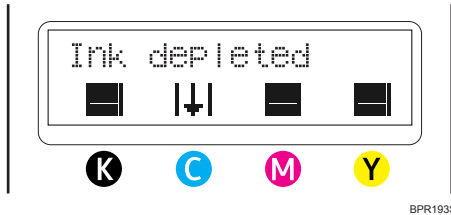

### Reference

- Be sure to insert the print cartridges correctly. If you insert them incorrectly, Status Monitor might not be able to detect the amount of ink that is remaining in the cartridges. For details about handling the print cartridges, see p. 195 "Handling Print Cartridges".

## Replacing a Print Cartridge

Follow the procedure below to replace an empty Print cartridge.

Clear any errors, such as when there is a paper jam or when no paper is loaded, before replacing a Print cartridge.

### CAUTION

- If ink comes into contact with your eyes, rinse immediately in running water. For other symptoms, consult a doctor.
- If ink is ingested, induce vomiting by drinking a strong saline solution. Consult a doctor immediately.
- If your skin comes into contact with ink, wash the affected area thoroughly with water or soap and water.
- Keep the ink or ink container out of reach of children.

### Important

- **Take care to install the cartridges in the correct position.**

#### 1. Remove the Print cartridges' packaging.

If multiple cartridges are empty, replace all the empty cartridges. You can shorten the time for needed replacement.

2. While pressing the recessed area (①) of the right front cover, open the cover (②).

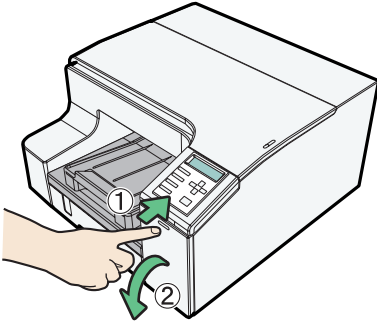

BUG113S

3. Take out the empty cartridges.

When doing this, be sure to hold the printer firmly so that it does not move.

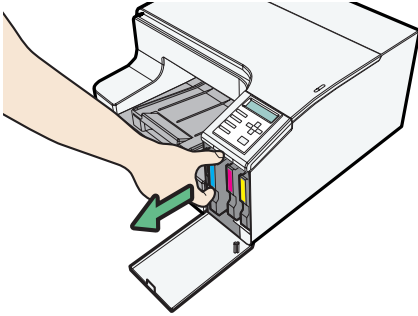

BUG140S

4. Check the cartridges' orientation, and then install them gently.

Install in the following order from the left: black, cyan, magenta, and yellow.

5. Push in the cartridge.

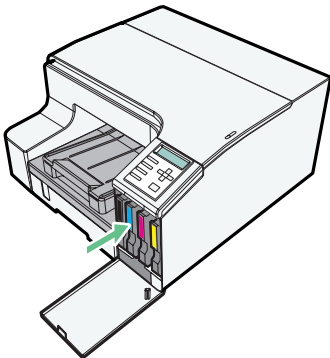

BUG141S

## 6. Close the right front cover.

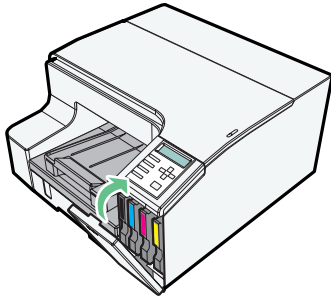

BUG115S

### Reference

- p.317 "Recommended Consumables"

## Handling Print Cartridges

Important points about handling Print cartridges are explained.

### **⚠ CAUTION**

- If ink comes into contact with your eyes, rinse immediately in running water. For other symptoms, consult a doctor.
- If ink is ingested, induce vomiting by drinking a strong saline solution. Consult a doctor immediately.
- If your skin comes into contact with ink, wash the affected area thoroughly with water or soap and water.
- Keep the ink or ink container out of reach of children.

### About Print cartridges

- Print cartridges comply with the manufacturer's safety specifications. To ensure safety and reliability, use genuine Print cartridges.
- When using the printer for the first time, install the Print cartridges supplied with the printer.
- As soon as you install the supplied print cartridges, the printer begins feeding ink to the print heads. Be sure not to reinstall used print cartridges.

### Using Print cartridges

- Print cartridges should be used up before their expiry date, ideally within six months of being removed from their packaging.
- Do not open the package of a Print cartridge until the cartridge will be installed in the printer.
- Do not touch the print cartridges' ink inlets or chip contacts.
- Do not shake Print cartridges strongly. Ink may leak out.

- Do not take apart Print cartridges.
- Do not open the right front cover except when installing Print cartridges. Do not turn off the power or unplug the power cord during the process of installing the cartridges.
- Always confirm the color of a Print cartridge before installing it.
- Do not remove a Print cartridge once it has been installed unless necessary.
- Do not remove a Print cartridge while printing is being performed. Printing will stop.
- For print quality and consistency, this printer always uses all the available ink colors (black, cyan, yellow, and magenta) to produce print images. Even if your print image is black and white or [Black and White] is selected in the printer properties dialog box, all ink colors will still be used.
- Printing stops if one of the print cartridges becomes empty. If a cartridge containing a color ink such as cyan, yellow, or magenta becomes empty, you cannot print, even in black/white. If a message prompting you to change the print cartridge appears, change the cartridge as soon as possible.

### **Storing Print cartridges**

- Store print cartridges at a temperature of between -30 and 43°C.

## **6**

### **Ink consumption**

- To protect the print head and ensure print quality, the printer performs periodic maintenance and print head cleaning when it is switched on and before printing. Both of these operations consume ink.
- The amount of ink consumed during cleaning depends on the cartridge size.

# Replacing an Ink Collector Unit

Follow the procedure below to replace an ink collector unit.

## WARNING

- Keep the polythene materials (bags, gloves, etc.) supplied with this machine away from babies and small children at all times. Suffocation can result if polythene materials are brought into contact with the mouth or nose.

## CAUTION

- Keep the ink collector unit out of reach of children.
- When replacing the ink collector unit, be careful not to spill ink on your clothes or nearby objects. Ink stains can be hard to remove.
- If ink comes into contact with your eyes, rinse immediately in running water. For other symptoms, consult a doctor.
- If ink is ingested, induce vomiting by drinking a strong saline solution. Consult a doctor immediately.
- If your skin comes into contact with ink, wash the affected area thoroughly with soap and water.

## Important

- Do not use an ink collector unit that has not been used for a long time.
- Do not touch the ink collector unit' chip contacts.
- Attach or detach the ink collector unit only when you replace it.
- Take care not to drop the ink collector unit.
- Take care not to drop the ink collector unit when putting it in the supplied plastic bag. The bag might tear, causing ink to spill.
- Make sure the ink collector unit is fully inserted. If it is not, ink will leak inside the printer.

Replace the ink collector unit when the following message appears on the control panel:

The following message appears when the ink collector unit is full.

Ink Collector  
Unit is Full

Replace Ink  
Collector Unit

1. Remove the ink collector unit' packaging.

2. While pressing the recessed area (①) of the right front cover, open the cover (②).

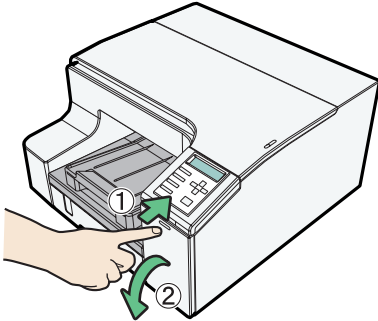

BUG113S

3. Wait at least five seconds, and then remove the full ink collector unit from the printer.

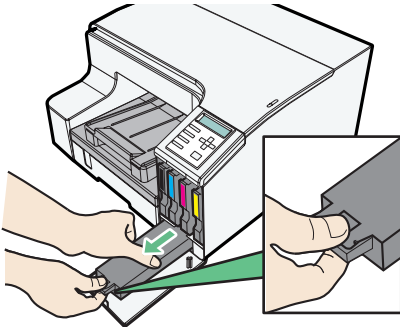

BUG185S

When pulling the unit out, keep the unit level and press on the area marked "Push".

4. Put the Ink collector unit in the supplied plastic bag.

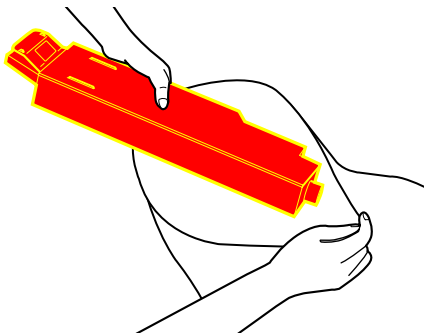

BPR186S



**5. Insert the new ink collector unit.**

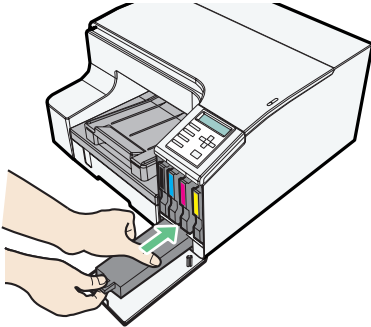

BUG187S

**6. Slide the ink collector unit carefully into the printer, until you hear it click.**

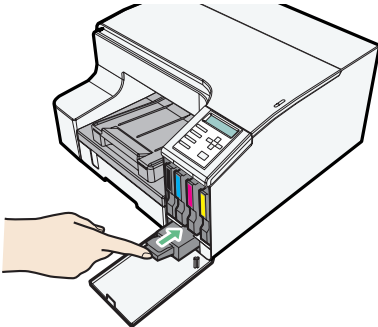

BUG194S

**7. Close the right front cover.**

# Cleaning

Clean the outside of the printer regularly to maintain the condition of the printer.

## **WARNING**

- To avoid hazardous electric shock, do not remove any covers or screws other than those specified in this manual. When the machine needs to be checked, adjusted, or repaired, contact your service representative.
- Do not take apart or attempt any modifications to this machine. There is a risk of fire, electric shock, explosion or loss of sight.

To clean the exterior of the printer, wipe it with a soft, dry or damp cloth. If the dirt does not come off, wipe the printer first with a cloth moistened with a neutral detergent, then with a damp cloth, and finally with a dry cloth.

## **Important**

- Do not use volatile chemicals like benzene or thinner, or insecticides on the printer. Using these chemicals could deform, crack, or change the color of the printer.
- When wiping the printer with a cloth moistened with detergent, be sure to wipe only the exterior.

---

## Cleaning the power Cable Plug

---

## **CAUTION**

- Be sure to disconnect the plug from the wall outlet and clean the prongs and the area around the prongs at least once a year. Allowing dust to build up on the plug constitutes a fire hazard.

# Moving

The precautions when moving the printer a short distance or long distance are explained.

## Moving a Short Distance

Take the following precautions when moving the printer a short distance - for instance, when attaching an optional tray or relocating the printer inside the same room.

### ⚠ CAUTION

- The machine weighs around 15.5 kg (34.2 lb) (29.9 kg (65.9 lb) with options installed).
- Careless handling and over exertion when lifting can result in breakage and/or injury.

### ★ Important

- Be sure to keep the printer level. If it is unduly tilted, ink will leak from the ink collector.
1. Turn the power off, disconnect the USB cable, or ethernet cable, and then unplug the power cord from the wall outlet.

Before moving the printer, be sure to disconnect the power cord from the printer, too.

2. Lift the printer and move it to the place where you want to install it.

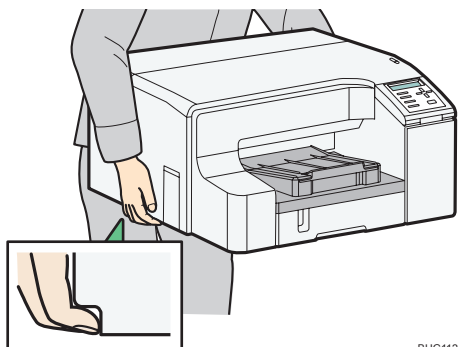

BUG112S

Grip the indented area at the base of the printer's sides, as shown. Lift and carry the printer slowly and carefully.

Make sure the power cord is not trapped under the printer.

## Moving a Long Distance

1. Turn the power off, disconnect the USB cable, or ethernet cable, and then unplug the power cord from the wall outlet. Do not remove the print cartridges. Remove the paper.

- 2. Pack the printer for transport when moving it a long distance such as when changing office or residence. Disconnect all cables, place the printer in the box it was in when purchased, and transport in a level manner.**

Contact sales or service representative for details.

 **Note**

- The inside of the printer may become dirty if the printer is not level when transported.
- When you move the printer, unplug the power cord from the printer, too.

# Disposing

Consult with an authorized dealer to dispose of the printer.

When disposing of the printer yourself, be sure to comply with local disposal regulations.

## When Not Using for a Long Period of Time

If the printer will not be used for a long time, turn its power off, disconnect the USB cable, and then unplug it from the wall outlet. It is recommended to print at least once a month, because the printer consumes a considerable amount of ink for periodic maintenance and print head cleaning when switched on after a long period of inactivity.

Be careful of the following:

- The nozzles of the print-heads may dry out and become clogged. To prevent this, periodically print something. Even if you do not print anything, turn the printer on for a few minutes once a month.
- If you do not use the printer for a long period of time, always check if the nozzles are clogged by printing a nozzle check test pattern. Clean the print-heads as necessary, and then begin printing.
- If you try to use the printer after it has been out of use for a long time, it may not print properly even if head cleaning is carried out several times. If this is the case, carry out head flushing. If the print heads are still clogged, leave the printer for about ten minutes, and then print the nozzle check pattern. If the problem persists, switch the printer off and leave it for at least eight hours. This should unclog the print heads.

**6**

### ↓ Note

- After head cleaning is performed multiple times, clogged ink will dissolve over time, and normal printing may become possible.
- If there is no improvement after performing the steps above, contact sales or service representative.

### 📖 Reference

- p.316 "Where to Inquire"
- p.160 "Nozzle Check"
- p.162 "Head-cleaning"
- p.165 "Head-flushing"

# 7. Troubleshooting

## Software Cannot Be Installed

This section explains how to troubleshoot software installation problems under different environments.

### Confirming Installation

Check whether the software has been installed.

|                       |   |
|-----------------------|---|
| Checking icons        | <p>When the printer driver is properly installed, the icon of the printer appears in the [Printers and faxes] folder.</p> <p>When installation of User Guide is complete, User Guide icon appears on your desktop.</p> <p>If the icons do not appear, the software is not properly installed. In this case, you must repeat the installation procedure. See p.57 "Quick Install for USB".</p>   |
| Checking the software | <p>You can install SmartDeviceMonitor for Client by clicking "Quick Install for Network" or "DeskTopBinder - SmartDeviceMonitor for Client".</p> <p>If SmartDeviceMonitor for Client is installed, the SmartDeviceMonitor for Client icon appears in the [SmartDeviceMonitor for Client] folder. To open the [SmartDeviceMonitor for Client] folder, select [Programs] on the [Start] menu, then select [DeskTopBinder], and then select [SmartDeviceMonitor for Client].</p> |
| Checking ports        | <p>In the printer properties dialog box, check that USB connection or network printer is selected as a port. To check the connection, perform a test print. If the test print is not printed, see p.209 "If Test Print Fails".</p>  |

### Checking Your Computer Environment

Check the system requirements for installing the software.

**Quick Install for USB**

|   |  |
|---|--|
| The CD-ROM may not be inserted properly.  | Check that the CD-ROM is inserted properly. Check also that it is not damaged and the CD-ROM drive is working properly.  |
| The power cord or USB cable may not be properly connected.                      | Check that the power cord and USB cable are properly connected and not damaged.  |
| The operating system is incompatible.<br>There is insufficient hard disk space. | Check that the computer's operating system is fully compatible with this printer. See p.35 "Checking the Computer and Installation Area".  |
| Other applications are not closed.  | When installing software, quit all other applications. Installation may be disrupted if other applications are open. Also, quit any anti-virus applications that are running.  |
| Windows made USB settings automatically.  | Open Windows' Device Manager, and then, under [Universal Serial Bus controllers], remove any conflicting devices. Conflicting devices have a yellow [!] or [?] icon by them. Take care not to accidentally remove required devices. For details, see p.211 "Deleting Devices".   |
| The printer is turned on before installation.                                   | Switch the printer off and then on, and then try Quick Install for USB again.  |
| The USB connection does not work.   | Switch the printer off, unplug the USB cable from the printer, launch "Quick Install for USB" again, and then switch the printer on when the dialog box confirming printer driver installation appears. If this does not solve the problem, press the [Menu] key on the control panel, change "USB Setting" in [Host Interface] from [Auto] to [Full Speed], uninstall the printer driver, delete the device, and then launch "Quick Install for USB" again. |
| An error occurs during software installation.                                   | If an error occurs because the printer is detected as an unidentified device, follow the instructions under "The USB connection does not work". If this does not solve the problem, do the following: First reboot Windows. Then, on the [Start] menu, select [Settings], and then select [Control Panel]. Double-click the System icon, and then on the [Hardware] tab, click [Device Manager]. Under [Other  |



|  |  |
|--|--|
|  | Devices], select the printer, and then open its properties dialog box. On the [General] tab, click [Reinstall Driver] to reinstall the software. |
|--|--|

### Quick Install for Network

|   |  |
|---|--|
| The CD-ROM may not be inserted properly.  | Check that the CD-ROM is inserted properly. Check also that it is not damaged and the CD-ROM drive is working properly.  |
| The power cord or Ethernet cable may not be properly connected.   | Check that the power cord and Ethernet cable are properly connected and not damaged.   |
| The operating system is incompatible.<br>There is insufficient hard disk space.                                   | Check that the computer's operating system is fully compatible with this printer. See p.35 "Checking the Computer and Installation Area".  |
| Other applications are not closed.  | When installing software, quit all other applications. Installation may be disrupted if other applications are open. Also, quit any anti-virus applications that are running.  |
| The printer's IP address has not been specified.<br>The computer and printer are not on the same network segment. | If the printer cannot be found and only "Printer Port" appears in the printer selection dialog box, either the printer's IP address has not been specified or the computer and printer are not on the same network segment. Before installing the software, check the printer's IP address and the network topology. Otherwise, select "Printer Port" in the dialog box, and then install the printer driver. If you do this, SmartDeviceMonitor for Client will not be simultaneously installed, so install it afterwards, and then configure the port. |
| A newer version of SmartDeviceMonitor for Client is already installed.  | If the version of SmartDeviceMonitor for Client already installed in the computer is newer than that on the CD-ROM, you cannot use "Quick Install" to install the printer driver. Install the printer driver, and then create the port.  |

## Printer Driver Cannot Be Installed

This section explains how to troubleshoot printer driver installation problems.

|  |   |
|--|---|
| <p>The printer driver installer does not start.<br/>An error occurs during installation.</p> | <ul style="list-style-type: none"> <li>• If the screen does not appear even when you double-click the SETUP.EXE icon, or if an error occurs during installation, access the CD-ROM drive from [My Computer] or [Explorer]. Double-click the RDISETP.EXE icon, and then install the printer driver by following the instructions that appear on the screen.</li> </ul> |
| <p>The printer driver installer does not start.<br/>An error occurs during installation.</p> | <ul style="list-style-type: none"> <li>• An error occurs if the path to the location of the stored data is too long. To install a printer driver downloaded from a Website or copied from a CD-ROM, save the printer driver directly on the hard disk, and then install it.</li> </ul>  |
| <p>The printer driver installer does not start.<br/>An error occurs during installation.</p> | <ul style="list-style-type: none"> <li>• On the [Start] menu, point to [Settings], and then click [Printers and faxes]. In the [Printers and faxes] window, install the printer driver. For details, see Windows Help.</li> </ul>   |

7

**USB Connection is not Automatically Detected**

If the USB connection is not automatically detected, do the following:

1. Delete the printer driver.
2. Delete the device.
3. Run [Quick Install for USB] again.

If these steps do not solve the problem, contact your sales or service representative.

**Reference**

- For details about deleting the printer driver, see p.210 "Uninstalling the Printer Driver".
- For details about deleting the device, see p.211 "Deleting Devices".
- For details about [Quick Install for USB], see p.57 "Quick Install for USB".

## If Test Print Fails

This section explains how to troubleshoot Test Print problems.

|  |   |
|--|---|
| The power cord or USB cable or Ethernet cable is not properly connected. | Check that the power cord and USB cable, Ethernet cable are properly connected.   |
| The port connection is not properly set.                                 | <ol style="list-style-type: none"> <li>1. On the [Start] menu, click [Printers and Faxes].</li> <li>2. Click the icon of the printer, and then click [Properties] on the [File] menu.</li> <li>3. Click the [Ports] tab, and then check the printer port. <ul style="list-style-type: none"> <li>• Select USB or network printer in the list when the selected port connection is something other than USB or network printer.</li> <li>• To connect via USB when USB does not appear in the list, you must re-install the printer driver. See p.208 "USB Connection is not Automatically Detected".</li> </ul> </li> </ol> |
| Ink feed is incomplete.  | <p>Ink begins automatically feeding into the print-heads when the power of the printer is first turned on or when a cartridge is replaced.</p> <p>Wait until ink feed is complete at which point the [Power] key stops blinking and remains lit.</p>  |
| The printer is offline.  | Check if the printer's on-line indicator is lit. If the printer is offline, press the [Online] key on the control panel to switch the printer to the on-line mode.  |
| A printer error has occurred.  | Use the control panel to check if a printer error has occurred. If it has, correct the error, and then perform the print again.   |

If you cannot solve the problem, contact sales or service representative.

### Reference

- If the Status monitor displays an error message, see p.254 "Status Monitor Errors".

# Uninstalling

If software was installed incorrectly or incompletely, uninstall and then reinstall it.

## ★ Important

- Before uninstalling software or deleting devices, turn off any other printers connected to your computer via USB, or disconnect the USB cable to the printers.

## ↓ Note

- Screens vary according to the operating environment.
- To reinstall the software, restart Windows.

## 📖 Reference

- When reinstalling the software, see p.66 "Confirming the Connection Method".

## Uninstalling the Printer Driver

To update the printer driver, uninstall the old printer driver before installing the new one.

## ★ Important

- The Status monitor installed with the current printer driver is uninstalled when the current printer driver is uninstalled.
- Registered custom settings are also deleted. To continue using registered custom settings, save them as custom settings files before uninstalling.

1. Press the printer's [Power] key to turn the printer off.

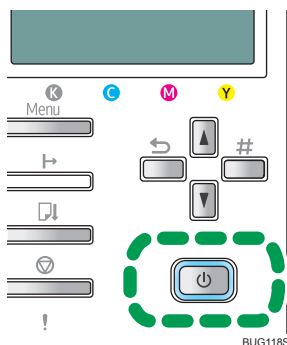

2. On the [Start] menu, click [Printers and Faxes].
3. Click the icon of the printer, and then click [Delete] on the [File] menu.  
A confirmation message appears.
4. Click [Yes].  
The printer driver is uninstalled.

5. Double-click [My computer].
6. On the [Tools] menu, click [Folder Options...].
7. Click the [View] tab.
8. In the [Advanced Settings:] box, click [Show hidden files and folders], and then deselect the [Hide extension for known file types] check box.
9. Click [OK].
10. On the [Start] menu, click [Search].
11. Click the [All files and folders], and then enter a file name in the [All or part of the file name:] field.  
Enter "RCDAD12K.inf" as the INF name.
12. In the [Look in:] box, select the hard disk on which Windows is installed, and then click [Search].
13. Right-click the file displayed as the search result, and then click [Delete].  
The INF file is uninstalled.
14. After uninstalling the printer driver, restart Windows.

### **E** Reference

- For details about storing registered custom settings, see the printer driver Help.
- For details about updating the printer driver, contact your sales or service representative.

## Deleting Devices

If Windows automatically establishes a USB connection because of an unauthorized device, you can delete the device and any others like it. Be sure not to delete necessary devices. If USB connection is established normally, you do not need to perform this procedure.

1. Press the printer's [Power] key to turn the printer on.

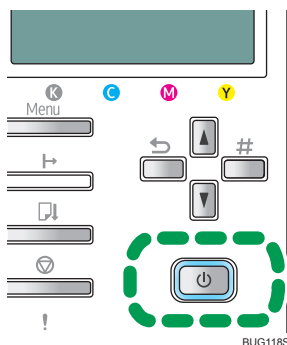

2. On the [Start] menu, click [Control Panel].
3. Click [Performance and Maintenance].

4. Click [System].
5. Click the [Hardware] tab.
6. Click [Device Manager].
7. Right-click [USB Printing Support] or [Product Name], and then click [Uninstall].  
A confirmation message appears.
8. Click [OK].
9. Click [Close].

---

## Printing Will Not Start

If printing will not start, check whether the power of the printer is on or whether the power can be turned on or not.

If an error occurs when you try printing, change the computer or printer driver settings.

---

### Power Cannot Be Turned On

---

If the [Power] key does not light or does not blink when it is pressed, check if there is something wrong with the power cord or wall outlet.

Check the following:

- Make sure that the power plug is firmly inserted into the wall outlet.
- Check if there is something wrong with the wall outlet. Do this by connecting another electronic product whose operation you are familiar with.

If the above steps do not solve the problem, turn the power off, pull out the power cable, and contact your sales or service representative. See p.316 "Where to Inquire".

---

### Paper Will Not Feed Even When the Power Is On

---

If printing will not start even when the power is on, check if an error has occurred using the indicators or Status monitor.

#### **An indicator is lit or blinking**

##### **Only the [Power] key is blinking.**

The printer may be receiving data or replenishing its ink. Wait momentarily for the blinking [Power] key to stop and stay lit.

#### **An error message is displayed on the Status monitor.**

Click [User Guide...] to display the page corresponding to the error where you can check how to solve the problem in more detail. See p.254 "Status Monitor Errors".

---

### An Error Occurs

---

If an error occurs when you try printing, change the computer or printer properties settings.

Do the following:

- Check the printer icon name does not exceed 32 alphanumeric characters.  
(If it does, shorten it.)

- Check whether other applications are operating.  
Close all other applications because these could be interfering with the installation. Be sure to close all resident programs also.
- Check the printer properties settings.  
In the [Change User Settings] dialog box, on the [Misc.] tab, select the [Change data processing] check box.
- Check whether the latest printer driver is being used.  
If the printer driver being used is not the latest one, update it with the latest version. See p.286 "Checking the Current Printer Driver Version".



# Paper Is Not Fed or Delivered Normally

If the printer is operating but paper will not feed or paper jams multiple times, check the condition of the printer and paper.

## **Paper does not feed smoothly.**

Paper guides are not adjusted properly.

- The paper guides of the paper tray do not match the paper loaded. Adjust the paper guides and load the paper again. See p.44 "Loading Paper".

Paper is not loaded properly.

- The paper is not loaded properly. Load the paper correctly. See Loading Paper.

Paper is curled.

- Remove the loaded paper and check if it is curled. If it is, straighten the curl within 2 mm (0.08 inches).

Paper that is not compatible is loaded.

- Remove the loaded paper and replace it with compatible paper. See p.91 "Non-compatible Paper".

## **Paper jams multiple times.**

The guide board is not closed.

- Make sure the guide board is closed. Press the board on both sides until it clicks into place. See p.20 "Guide to Components".

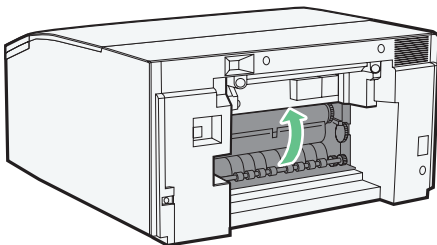

BUG142S

Push the PUSH area on both sides of the guide board until it firmly closes.

Printing densely colored images on both sides.

- When printing images containing areas of solid color that consume a lot of ink, we recommend single-sided printing.

**Multiple sheets of paper are fed at one time.**

Load the paper again. Remove the paper from the paper tray, fan it well, and tap it on a flat surface such as a desk to even the edges. Check the position of the paper guides of the paper tray, and then load the paper again. See p.87 "Paper Handling Precautions", p.44 "Loading Paper".

**Though a paper jam is cleared, paper does not feed.**

When a paper jam occurs, clear the paper jam, and then press the [Form Feed] key. See p.217 "Using the [Form Feed] Key to Remove Jammed Paper".

**The bypass tray cannot be selected.**

The printer driver cannot detect the bypass tray.

If the bypass tray cannot be detected, open the printer properties dialog box. In [Bypass Tray Unit] on the [Accessories] tab in the printer properties dialog box, check whether the bypass tray is shown as being attached.

**Paper is jammed in the duplex unit.**

The duplex unit is properly locked into position. but not locked.

Attach the duplex unit properly. For details, see p.271 "Duplex Unit Not Detected".

**Note**

- If an error is displayed on the Status monitor, follow the instructions to solve the problem. See p.254 "Status Monitor Errors".

# Paper Jam

This explains how to remove a paper jam.

When a paper jam error appears in the Status monitor, remove the paper from the location indicated.

If you cannot locate paper jams or jammed paper cannot be removed easily, you can check the condition of paper from the top of the printer.

## Reference

- p.31 "Detaching and Reattaching the Multi Bypass Tray"

## Using the [Form Feed] Key to Remove Jammed Paper

This section explains how to use the [Form Feed] key to remove jammed paper.

### 1. Press the [Form Feed] key.

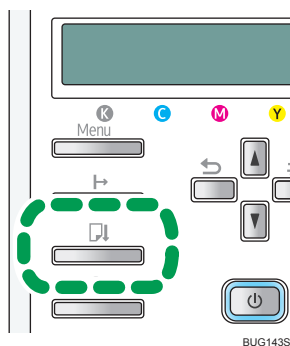

### 2. Remove jammed paper.

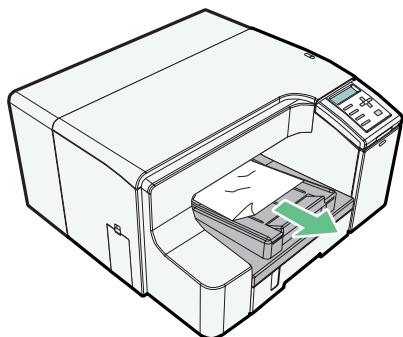

Printing starts.

## Note

- Sometimes, pressing the [Form Feed] key will not remove the jammed paper. If this is the case, pull Tray 1 out and remove the jammed paper manually.

### Reference

- p.215 "Paper Is Not Fed or Delivered Normally"
- p.218 "Removing Paper Jammed in Tray 1"
- p.223 "Removing Paper Jammed in the Multi Bypass Tray (optional)"
- p.227 "Removing Paper Jammed under the Top Cover"
- p.230 "Removing Paper Jammed around the Guide Board"
- p.234 "Removing Paper Jammed in the Duplex Unit"
- p.237 "If You Cannot Remove Jammed Paper"

## Removing Paper Jammed in Tray 1

Follow the procedure below to remove paper jammed in tray 1.

You can feed the jammed paper to output ramp by opening the left cover and turning the paper feed wheel.

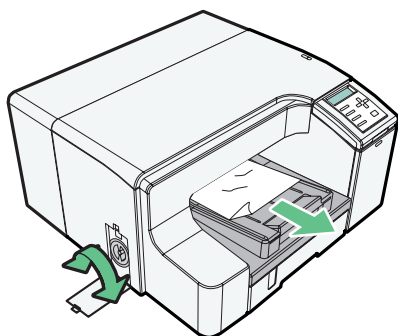

BUG145S

If turning the paper wheel does not remove the jammed paper, use the following procedure to remove it:

1. Hold the grip on tray 1, lift the tray slightly (①), and then pull it out (②).

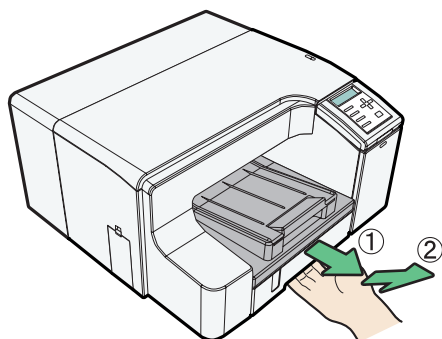

BUG183S

Pull tray 1 completely out. Take care not to drop it.

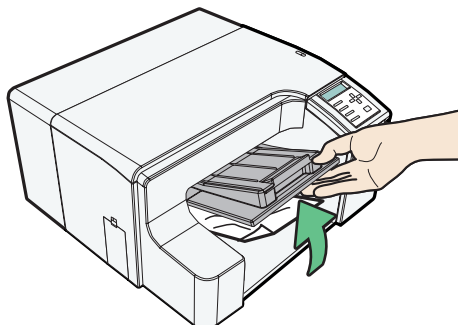
**2. Open the output ramp.**

BUG184S

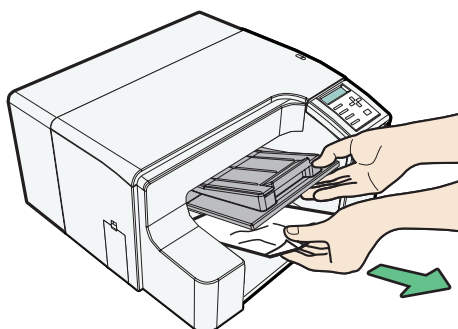
**3. Remove jammed paper.**

BUG146S

If you cannot remove the jammed paper or it is difficult to remove, the paper may be jammed inside the printer. Examine the paper carefully and remove.

**4. Close the output ramp.**

BUG202S

5. Push tray 1 gently in until it stops.

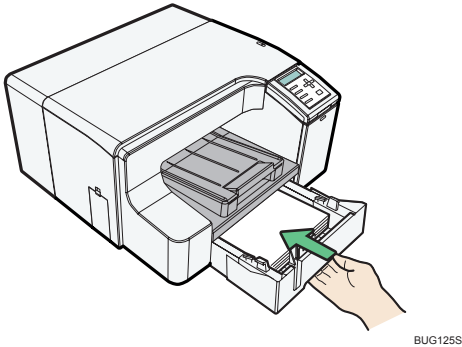

Printing starts.

Blank paper may be delivered after printing resumes.

**Reference**

- p.215 "Paper Is Not Fed or Delivered Normally"
- p.220 "Removing Paper Jammed in Tray 2/Tray 3 (optional)"
- p.222 "Removing Paper Jammed in the Rear Unit (optional)"
- p.223 "Removing Paper Jammed in the Multi Bypass Tray (optional)"
- p.227 "Removing Paper Jammed under the Top Cover"
- p.230 "Removing Paper Jammed around the Guide Board"
- p.234 "Removing Paper Jammed in the Duplex Unit"
- p.237 "If You Cannot Remove Jammed Paper"

7

## Removing Paper Jammed in Tray 2/Tray 3 (optional)

Follow the procedure below to remove paper jammed in tray 2/tray 3.

1. Hold the grip on tray 2/tray 3, lift the tray slightly (①), and then pull it out (②).

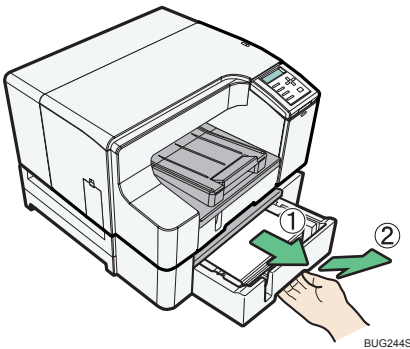

Pull tray 2/tray 3 completely out. Take care not to drop it.

## 2. Remove jammed paper.

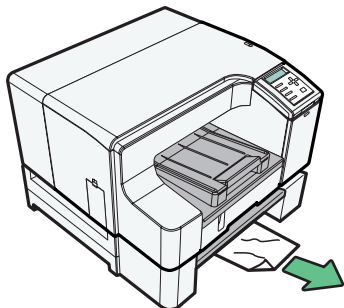

BUG226S

## 3. Push tray 2/tray 3 gently in until it stops.

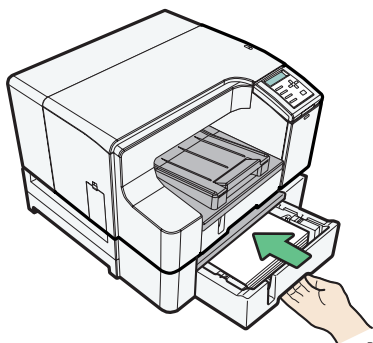

BUG223S

## 4. Press the [Form Feed] key.

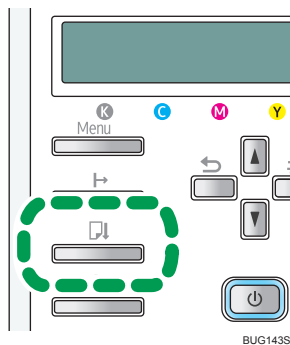

BUG143S

Printing starts.

Blank paper may be delivered after printing resumes.

### Reference

- p.215 "Paper Is Not Fed or Delivered Normally"
- p.218 "Removing Paper Jammed in Tray 1"

- p.222 "Removing Paper Jammed in the Rear Unit (optional)"
- p.223 "Removing Paper Jammed in the Multi Bypass Tray (optional)"
- p.227 "Removing Paper Jammed under the Top Cover"
- p.230 "Removing Paper Jammed around the Guide Board"
- p.234 "Removing Paper Jammed in the Duplex Unit"
- p.237 "If You Cannot Remove Jammed Paper"

---

## Removing Paper Jammed in the Rear Unit (optional)

---

Follow the procedure below to remove paper jammed in the rear unit.

1. Holding the rear handle, remove each rear unit located behind Tray 2/Tray 3.

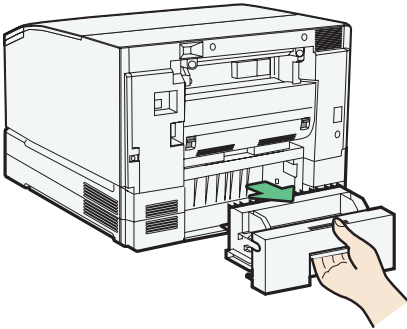

BUG240S

2. Remove jammed paper.

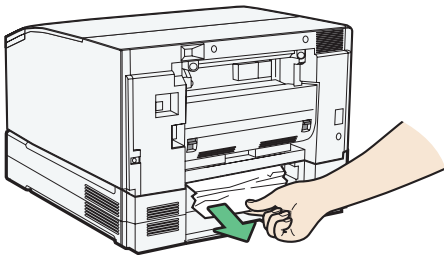

BUG241S



### 3. Attach the rear unit.

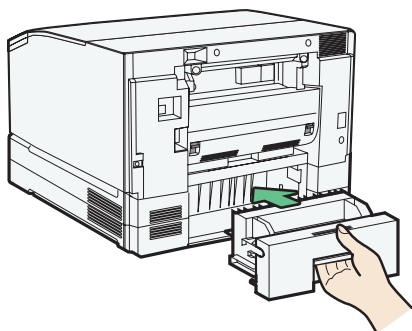

BUG242S

Printing starts.

Blank paper may be delivered after printing resumes.

#### Reference

- p.218 "Removing Paper Jammed in Tray 1"
- p.220 "Removing Paper Jammed in Tray 2/Tray 3 (optional)"
- p.223 "Removing Paper Jammed in the Multi Bypass Tray (optional)"
- p.227 "Removing Paper Jammed under the Top Cover"
- p.230 "Removing Paper Jammed around the Guide Board"
- p.234 "Removing Paper Jammed in the Duplex Unit"
- p.237 "If You Cannot Remove Jammed Paper"

7

## Removing Paper Jammed in the Multi Bypass Tray (optional)

Follow the procedure below to remove paper jammed in the bypass tray.

You can feed the jammed paper to output ramp by opening the left cover and turning the paper feed wheel.

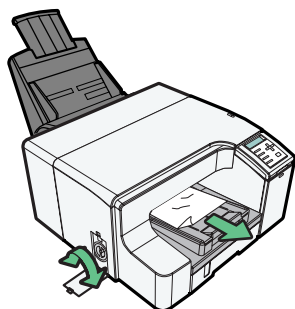

BUG147S

If turning the paper wheel does not remove the jammed paper, use the following procedure to remove it:

**1. Remove any paper in the bypass tray.**

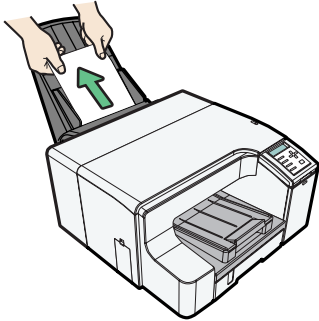

BUG148S

**2. Remove jammed paper.**



BUG149S

**3. Load paper in the bypass tray with the side to be printed on facing up.**

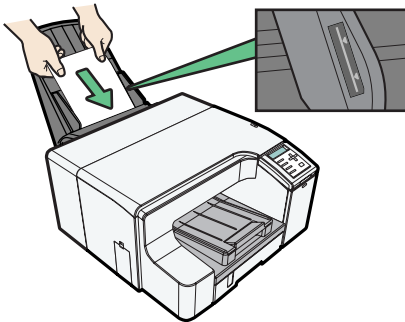

BUG126S

If it is difficult to remove jammed paper, follow the procedure below to remove it.

1. Remove any paper in the bypass tray.

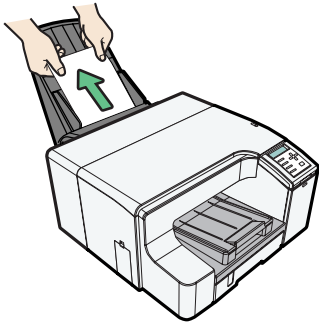

BUG148S

2. Push the bypass tray extension in.
3. Detach the bypass tray.

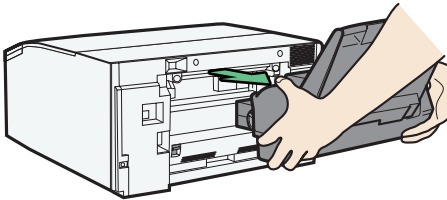

BUG108S

4. Remove the jammed paper from the rear of the printer.

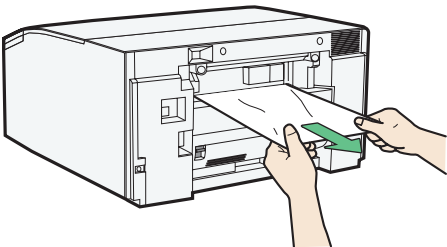

BUG188S

**5. Reattach the bypass tray.**

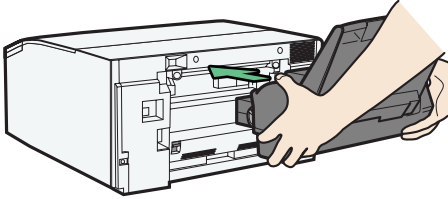

BUG109S

**6. Pull the bypass tray extension out.**

**7. Load paper in the bypass tray with the side to be printed on facing up.**

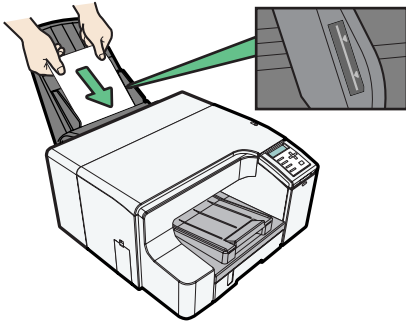

BUG126S

**Note**

- If you cannot remove the jammed paper using the above procedure, clear the jam from the multi bypass tray.

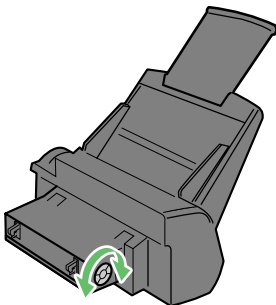

BPR163S

- Turn the knob on the bypass tray clockwise to eject the jammed paper.
- If this does not eject the paper, turn the knob one-turn counterclockwise, and then turn it clockwise. This will eject the paper.

## Reference

- p.215 "Paper Is Not Fed or Delivered Normally"
- p.218 "Removing Paper Jammed in Tray 1"
- p.220 "Removing Paper Jammed in Tray 2/Tray 3 (optional)"
- p.222 "Removing Paper Jammed in the Rear Unit (optional)"
- p.227 "Removing Paper Jammed under the Top Cover"
- p.230 "Removing Paper Jammed around the Guide Board"
- p.234 "Removing Paper Jammed in the Duplex Unit"
- p.237 "If You Cannot Remove Jammed Paper"

## Removing Paper Jammed under the Top Cover

Follow the procedure below to remove paper jammed under the top cover.

### ★ Important

- If the printer's ink tube is preventing access to the jammed paper, carefully pull the tube to the side. Do not pull the tube upward. Pulling the tube upward will damage the printer.
- Do not touch the feed belt, the transparent black band, print head rail rod, ink tubes, paper pressing board, or the toothed rubber belt. Also, take care not to snag any cables or ink tubes with your sleeves.

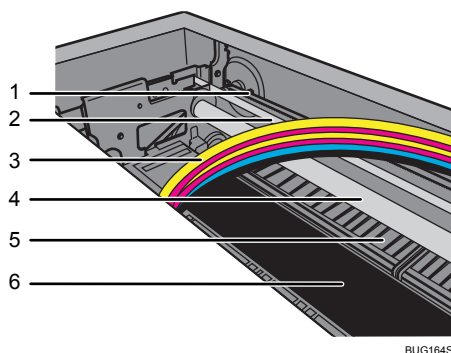

1. Toothed rubber belt
2. Transparent black band
3. Ink tubes
4. Print Head Rail Rod
5. Paper pressing board
6. Feed belt

You can feed the jammed paper to output ramp by opening the left cover and turning the paper feed wheel.

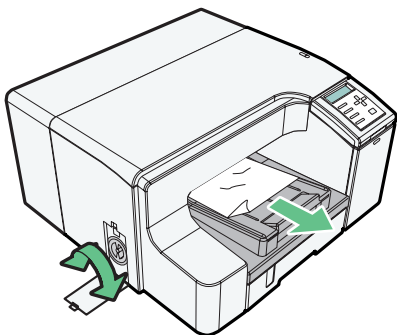

BUG145S

If turning the paper wheel does not remove the jammed paper, use the following procedure to remove it:

**1. Open the top cover.**

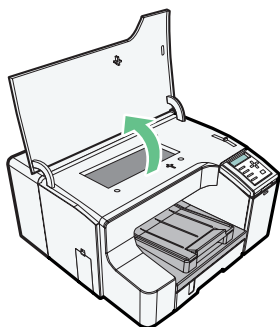

BUG178S

**2. Open the left cover, and then turn the paper feed wheel.**

Turn the wheel while looking for the jammed paper through the top cover opening.

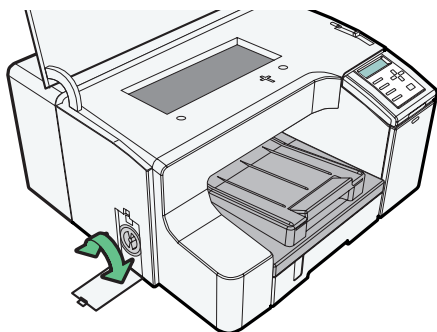

BUG179S

### 3. Remove the jammed paper through the top cover opening.

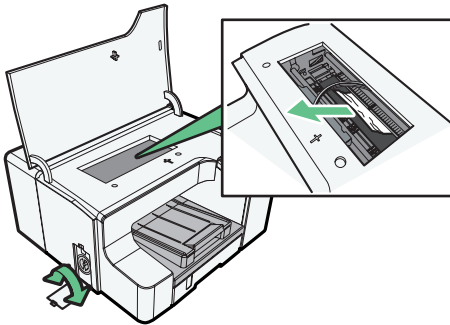

BUG180S

If the carriage has stopped halfway, move it to either end.

### 4. Close the left cover.

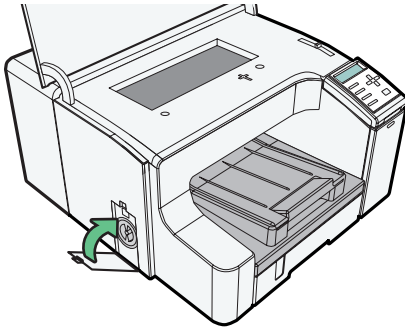

BUG181S

### 5. Close the top cover.

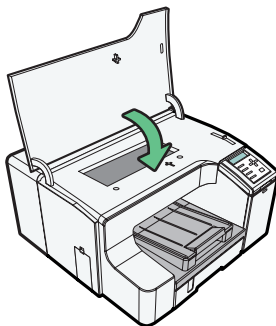

BUG182S

Printing starts.

After completing this procedure, print the nozzle check test pattern to make sure the print head's nozzles are not clogged.

**Note**

- Align the paper and reload it in the paper tray. Loading paper over the limit line in the tray may result in a paper jam.

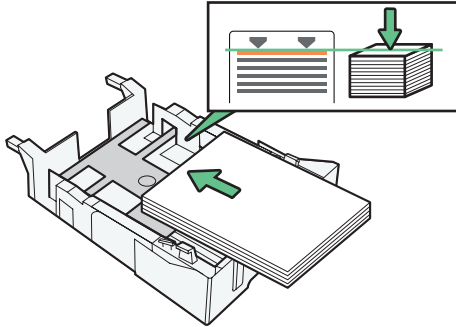

BPR122S

**Reference**

- p.44 "Loading Paper"
- p.160 "Nozzle Check"
- p.218 "Removing Paper Jammed in Tray 1"
- p.220 "Removing Paper Jammed in Tray 2/Tray 3 (optional)"
- p.222 "Removing Paper Jammed in the Rear Unit (optional)"
- p.223 "Removing Paper Jammed in the Multi Bypass Tray (optional)"
- p.230 "Removing Paper Jammed around the Guide Board"
- p.234 "Removing Paper Jammed in the Duplex Unit"
- p.237 "If You Cannot Remove Jammed Paper"

## Removing Paper Jammed around the Guide Board

Follow the procedure below to remove paper jammed around the guide board.

**Important**

- If the bypass tray is attached to the printer, switch the printer off and detach the duplex unit.

**1. Pressing the catches on both side of the duplex unit, remove the unit.**

Detach the duplex unit completely so you can see the guide board in the recess.



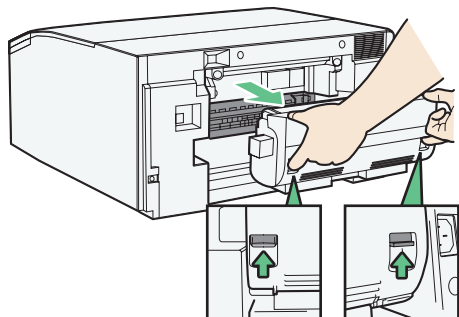

BUG150S

2. Unlock the guide board by moving the tabs on both sides toward the middle, and then open the guide board.

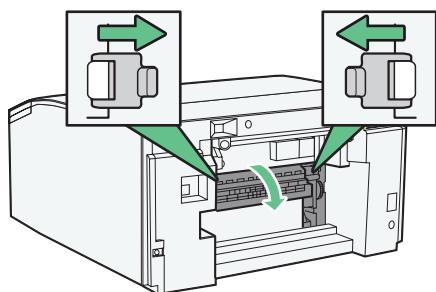

BUG151S

3. Open the left cover.

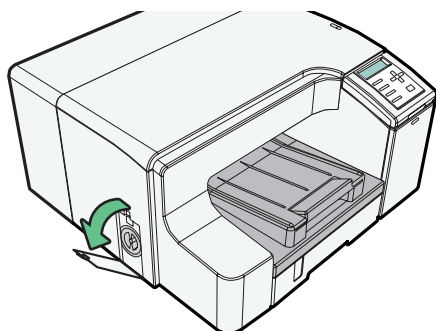

BUG152S

4. Turn the paper feed wheel to release paper from the feed belt.

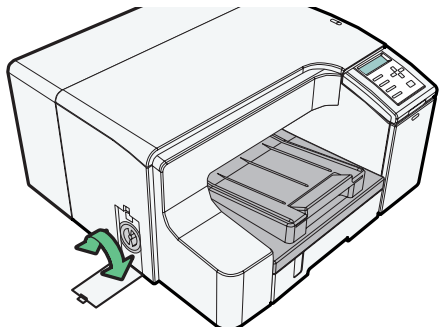

BUG153S

Release paper from the feed belt to make it removable.

5. Insert your finger between the paper and the feed belt, and then remove the paper slowly.

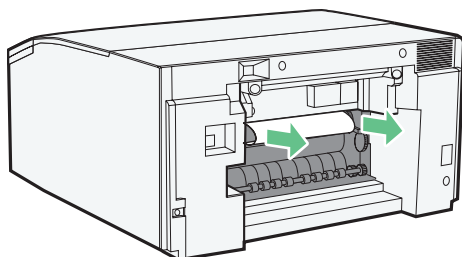

BUG154S

Do not touch the feed belt.

6. Close the guide board.

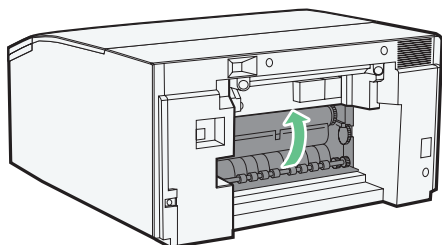

BUG142S

Push the PUSH area on both sides of the guide board until it firmly closes.

7. Without pressing the catches on its sides, push the duplex unit all the way in until it clicks into place.

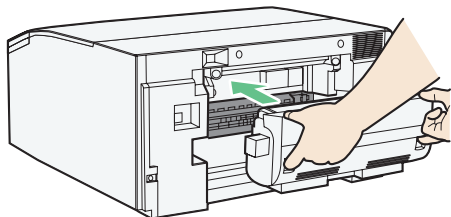

BUG155S

8. Close the left cover.

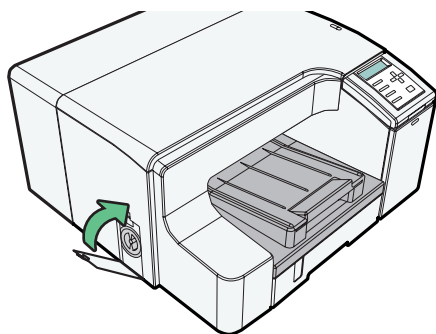

BUG156S

Printing starts.

**Note**

- Depending on how the paper was jammed, printing may resume from the next page, not the one jammed.

**Reference**

- p.215 "Paper Is Not Fed or Delivered Normally"
- p.31 "Detaching and Reattaching the Multi Bypass Tray"
- p.218 "Removing Paper Jammed in Tray 1"
- p.220 "Removing Paper Jammed in Tray 2/Tray 3 (optional)"
- p.222 "Removing Paper Jammed in the Rear Unit (optional)"
- p.223 "Removing Paper Jammed in the Multi Bypass Tray (optional)"
- p.227 "Removing Paper Jammed under the Top Cover"
- p.234 "Removing Paper Jammed in the Duplex Unit"
- p.237 "If You Cannot Remove Jammed Paper"

## Removing Paper Jammed in the Duplex Unit

Follow the procedure below to remove paper jammed in the duplex unit.

**★ Important**

- Make sure the duplex unit is attached properly.
- If the bypass tray is attached to the printer, switch the printer off and detach the bypass tray.

You can feed the jammed paper to output ramp by opening the left cover and turning the paper feed wheel.

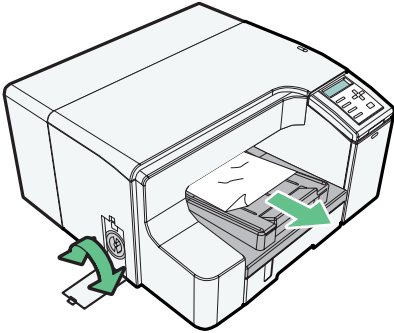

BUG145S

If turning the paper wheel does not remove the jammed paper, use the following procedure to remove it:

7

1. Press the duplex unit cover button at the center of the bypass tray, and then open the duplex unit cover.

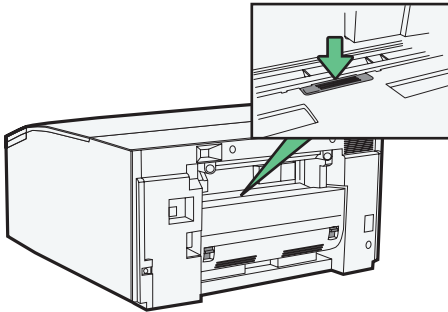

BUG157S

## 2. Remove jammed paper.

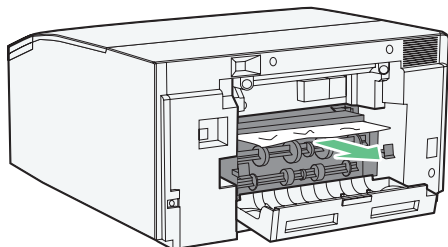

BUG158S

## 3. Close the duplex unit cover.

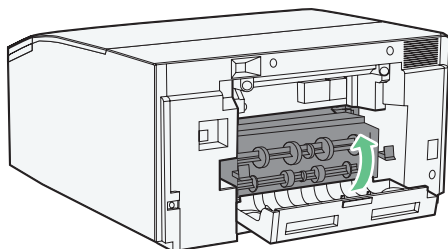

BUG159S

If the bypass tray has been detached, be sure to switch the power off before reattaching the tray.  
Printing starts.

**If it is difficult to remove jammed paper, follow the procedure below to remove it.**

### 1. Pressing the catches on both side of the duplex unit, remove the unit.

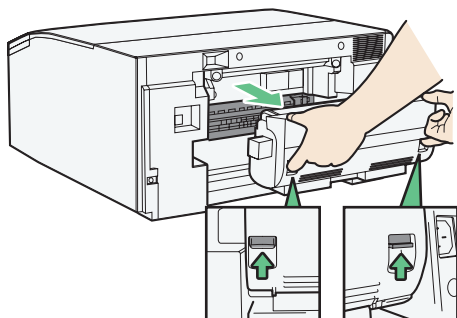

BUG150S

**2. Remove the jammed paper from the rear of the printer.**

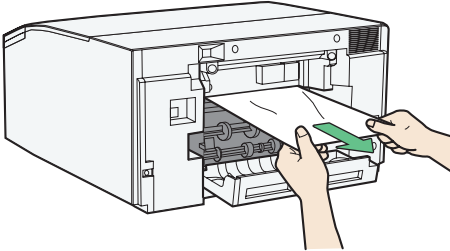

BUG160S

**3. Without pressing the catches on its sides, push the duplex unit all the way in until it clicks into place.**

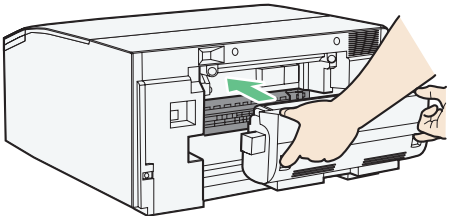

BUG155S

If the bypass tray has been detached, be sure to switch the power off before reattaching the tray.

**Note**

- Depending on how the paper was jammed, printing may resume from the next page, not the one jammed.

**Reference**

- p.31 "Detaching and Reattaching the Multi Bypass Tray"
- p.218 "Removing Paper Jammed in Tray 1"
- p.220 "Removing Paper Jammed in Tray 2/Tray 3 (optional)"
- p.222 "Removing Paper Jammed in the Rear Unit (optional)"
- p.223 "Removing Paper Jammed in the Multi Bypass Tray (optional)"
- p.227 "Removing Paper Jammed under the Top Cover"
- p.230 "Removing Paper Jammed around the Guide Board"
- p.237 "If You Cannot Remove Jammed Paper"

## If You Cannot Remove Jammed Paper

This section explains how to remove badly jammed paper that you cannot remove by the usual methods.

### ★ Important

- If the bypass tray and duplex unit are attached to the printer, switch the printer off and detach the duplex unit.
- Do not touch the feed belt, the transparent black band, print head rail rod, ink tubes, paper pressing board, or the toothed rubber belt. Also, take care not to snag any cables or ink tubes with your sleeves.

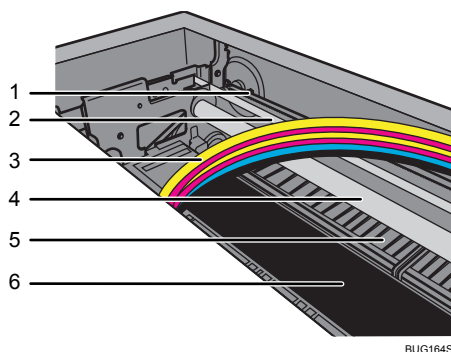

1. Toothed rubber belt
2. Transparent black band
3. Ink tubes
4. Print Head Rail Rod
5. Paper pressing board
6. Feed belt

- If the printer's ink tube is preventing access to the jammed paper, carefully pull the tube to the side. Do not pull the tube upward. Pulling the tube upward will damage the printer.

1. Open the top cover.

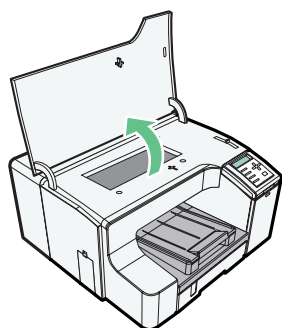

**2. Open the left cover, and then turn the paper feed wheel.**

Turn the wheel while looking for the jammed paper through the top cover opening.

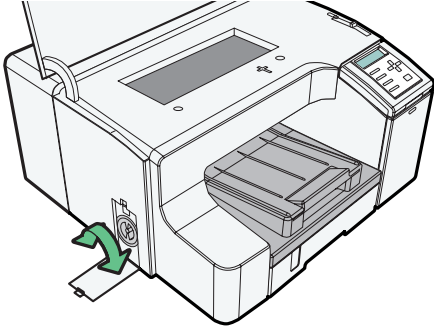

BUG179S

**3. Remove the jammed paper through the top cover opening or back of the printer.**

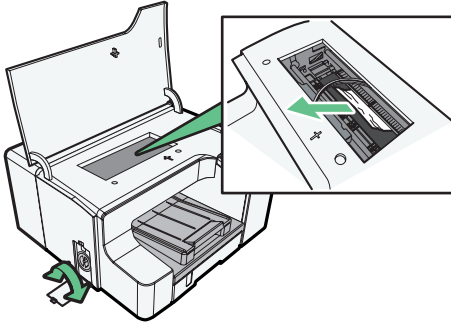

BUG180S

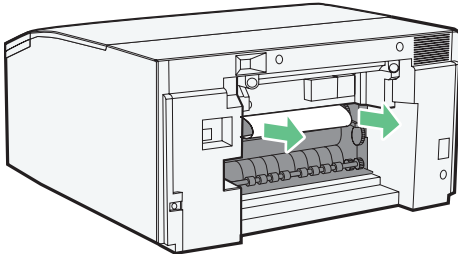

BUG154S

Before removing jammed paper from the back of the printer, remove the duplex unit.



#### 4. Close the left cover.

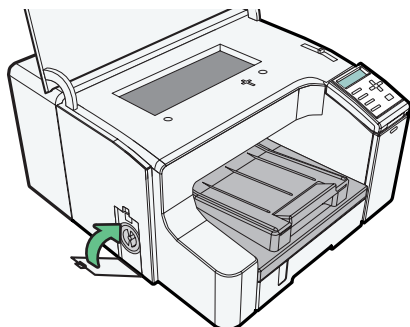

BUG181S

#### 5. Close the top cover.

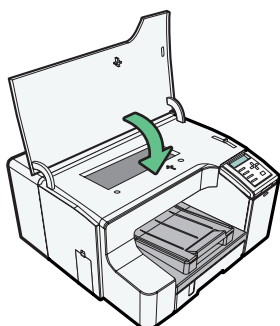

BUG182S

Printing starts.

#### ↓ Note

- Align the paper and reload it in the paper tray. Loading paper over the limit line in the tray may result in a paper jam.

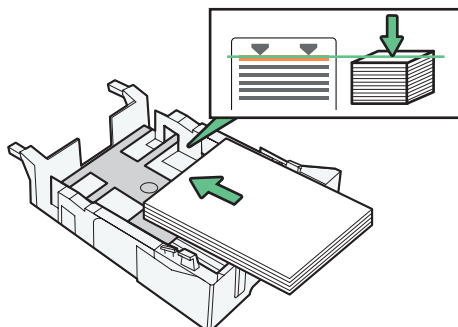

BPR122S

#### 📖 Reference

- p.218 "Removing Paper Jammed in Tray 1"
- p.220 "Removing Paper Jammed in Tray 2/Tray 3 (optional)"

- p.222 "Removing Paper Jammed in the Rear Unit (optional)"
- p.223 "Removing Paper Jammed in the Multi Bypass Tray (optional)"
- p.227 "Removing Paper Jammed under the Top Cover"
- p.230 "Removing Paper Jammed around the Guide Board"
- p.234 "Removing Paper Jammed in the Duplex Unit"
- p.44 "Loading Paper"

# Print Results Are Not Satisfactory

If print quality is poor, check the printer and printer driver settings for problems. If no problems are apparent, check the print cartridge or other consumables.

## Prints are Unsatisfactory

This section explains how to troubleshoot the printer when printing is uneven (due to the wrong amount of ink being used) or when prints are smudged, smeared, or blotchy.

### Have you printed the nozzle check test pattern?



Print the nozzle check test pattern to check whether the print head nozzles are all ejecting ink properly, and, if necessary, carry out head cleaning or head-flushing. The procedure is as follows:

1. Print the nozzle check test pattern.
2. If the pattern is patchy, clean the print head, print the pattern again, and then check the result.
3. Do not use the printer for 5 to 10 minutes then, print the nozzle check test pattern again, and then check the result.
4. Clean the print head and print the nozzle check test pattern, clean and print a second time, and then check the result.
5. If the pattern is still patchy, flush the print head, print the pattern again, and then check the result.
6. Do not use the printer for 5 to 10 minutes, print the nozzle check test pattern again, and then check the result.
7. If the pattern is still patchy, switch the printer off, do not use it for about 8 hours, switch it back on, print the nozzle check test pattern, and then check the result.

If the pattern is still patchy, contact your sales or service representative.

See p.160 "Nozzle Check", p.162 "Head-cleaning" and p.165 "Head-flushing".

### Does the envelope selector setting match?

Set the envelope selector according to the type of paper. For envelopes, set the lever to the rear position ; for everything else, set the lever to the forward position . See p.279 "Envelope Selector Position Mismatch".

### Has the printer not been used for a long time?

The ink may be dry or the nozzles of the print-heads may be clogged. Print the nozzle check test pattern and clean the print-heads as necessary. See p.160 "Nozzle Check", p.162 "Head-cleaning".

### Have you changed the envelope selector setting?

Depending on the thickness of the envelopes, changing the envelope selector setting might result in blurred or double lines being printed. If you switch the envelope selector to , be sure to select [Head Position],

as this will position the print heads correctly. If you switch the envelope selector to , be sure to select the [Uni-directional printing only] check box in the printer properties dialog box.

### **Have the print-heads been aligned?**

Blurred or double lines indicate the print heads are incorrectly positioned. Resolve this by switching the envelope selector to  and then selecting [Head Position]. If the problem persists, print the nozzle check test pattern and clean the print-heads as necessary. See p.166 "Head Position", p.160 "Nozzle Check" and p.162 "Head-cleaning".

### **Is there a problem with the printer's location?**

Make sure that the printer is level. Place the printer in a location where it will not be subject to shaking or excessive force.

### **Have you performed registration?**

Perform registration if the print start point indicates misalignment.

After attaching the paper feed unit, and the bypass tray, you must register where to start printing on paper loaded in each paper tray. See p.170 "Registration".

### **Have you changed the paper feed setting?**

If horizontal lines are printed unaligned, print images are patchy, or a black or white line is printed at regular intervals, print a test pattern, and then adjust the paper feed setting. p.168 "Adj.Paper Feed".

### **Does the paper type setting match?**

Make sure that the paper type setting of the printer driver matches the type of paper loaded.

### **Are you printing on the wrong side of the paper?**

Check which side should be printed on when using inkjet plain paper. If you print on the wrong side, the quality of the printing may be lower and the inside of the printer may get dirty. See p.87 "Paper Handling Precautions", p.84 "Compatible Paper Types"

### **Is the paper being used too thick or thin?**

Check if the paper is compatible. The print heads will rub against paper that is too thick or thin, and this will cause smearing. See p.84 "Loadable Paper Sizes and Quantities".

### **Have you touched the printed side of paper?**

Avoid touching the printed side of paper. Particularly, avoid touching glossy paper that have just been printed because these require longer than normal to dry. Remove them one at a time from the output ramp without touching the printed side, and then let them dry fully. See p.87 "Paper Handling Precautions".

### **Is the paper loaded in the correct orientation?**

Some paper cannot be loaded lengthwise depending on the size of the paper. Check the orientation in which the paper is loaded. See p.84 "Loadable Paper Sizes and Quantities".

---

### **Are you printing densely colored images on both sides of paper?**

When a large amount of ink is used to completely cover a side, one-sided printing is recommended.

---

## **Colors Do Not Match the Displayed Image**

---

If there are differences between colors of the print results and the displayed image, the following questions should be addressed.

### **Has the hue of colors been adjusted?**

Since printed colors and screen colors are produced by different methods, a color printed and a color displayed on a screen can have different hues even though they are the "same" color. Use the color matching function to make the hue of printed colors and displayed colors closer.

### **Has the nozzle check been performed?**

The print-heads may be clogged and the amount of ink may not be able to be regulated. Print the nozzle check test pattern and clean the print-heads as necessary. See p.160 "Nozzle Check", p.162 "Head-cleaning".

### **Was printing done in black and white?**

Check the color setting of the application and the color print setting of the printer driver.

### **Have the print quality settings been made?**

In the [Print Quality] area, select [Quality priority], or [Speed priority], and then print.

### **Does the paper type setting match?**

Make sure that the paper type setting of the printer driver matches the type of paper loaded.

### **Have you tried printing with inkjet plain paper?**

Try printing with inkjet plain paper. The print results should be clearer.

---

## **Positions Do Not Match the Displayed Image**

---

If the position of printed items differs from the position of displayed items, the following questions should be addressed.



### **Have the settings for page layout been made?**

Check whether page layout settings have been made with the application.

### **Does the paper size setting match?**

Make sure that the paper size selected in the [Printout paper size:] list of the printer properties dialog box matches the size of the paper loaded.

**Does the envelope selector setting match?**

Set the envelope selector according to the type of paper. For envelopes, set the lever to the rear position ; for everything else, set the lever to the forward position . See p.279 "Envelope Selector Position Mismatch".

Blurred or double lines indicate the print heads are incorrectly positioned. Resolve this by switching the envelope selector to  and then selecting [Head Position].

**Have the print-heads been aligned?**

When bidirectional printing is performed, switch the envelope selector to  and select [Head Position] to align the print heads. If the problem persists, print the nozzle check test pattern and clean the print-heads as necessary. See p.166 "Head Position", p.160 "Nozzle Check" and p.162 "Head-cleaning".

**Have you changed Printable area?**

The problem may be solved by changing [Printable area:] in the printer properties dialog box. On the [Printer Configuration] tab, set [Printable area:] to [Maximum].

**Have you changed Print Quality?**

In the [Print Quality] area, select the [Uni-directional printing only] check box. Note, however, that this will slow printing down.

**Is Binding Margins set correctly?**

On the [Edit] tab, in the [Header/Footer/Adjust image position/Binding margins] dialog box, specify [Adjust Image Position] correctly.

---

**Other Problems**

---

You may eliminate certain problems by changing the printer driver settings as described below:

**Cannot print certain data properly when using a certain application, or cannot print image data properly.**

- In the [Print Quality] area, select [Quality priority], and then print.
- In the [Change User Settings] dialog box, on the [Image Adjustments] tab, under [Dithering], deselect the [Use error diffusion] check box.
- Set [Spool format:] to [RAW] or [EMF] in the [Printer Configuration] tab.
- In the [Change User Settings] dialog box, on the [Image Adjustments] tab, under [Image processing priority], deselect the [Adjust photos and images] and [Smooth low resolution images] check boxes.
- In the [Change User Settings] dialog box, on the [Misc.] tab, select the [Print as bitmap] check box.
- On the [Printer Configuration] tab, set [Adjust Color Density] to [Darker] or [Lighter], and then print.
- In the [Print Quality-User settings] dialog box, on the [Color Settings] tab, specify [Gray reproduction (Text/Line Art):].

### **Some characters are garbled or missing.**

- In the [Change User Settings] dialog box, on the [Misc.] tab, select the [Change methods to extract TrueType fonts] check box.
- In the [Printer Configuration] tab, set [Spool format:] to [EMF]. In the [Change User Settings] dialog box, on the [Misc.] tab, select the [Print as bitmap] check box.

### **Some characters are printed faintly or not printed.**

- In the [Print Quality] area, select [Quality priority], and then print.
- In the [Change User Settings] dialog box, on the [Image Adjustments] tab, under [Dithering], deselect the [Use error diffusion] check box.
- On the [Printer Configuration] tab, set [Spool format:] to [RAW] or [EMF].
- On the [Printer Configuration] tab, select the [Increase bold with font size] check box.
- In the [Print Quality-User settings] dialog box, on the [Color Settings] tab, specify [Gray reproduction (Text/Line Art):].
- To print text in black, in the [Print Quality-User settings] dialog box, on the [Color Settings] tab, select the [K (Black) for text only] check box.

### **Printing is slow and takes time, which delays release of the application.**

- In the [Print Quality] area, select [Speed priority] or [High speed], and then print.
- In the [Printer Configuration] tab, set [Spool format:] to [EMF].
- In the [Change User Settings] dialog box, on the [Image Adjustments] tab, under [Image processing priority], deselect the [Adjust photos and images] and [Smooth low resolution images] check boxes.
- Close the resident application.

### **Printing stops halfway.**

View the status monitor to check whether an error has occurred. See p.254 "Status Monitor Errors".

To print on pre-printed or pre-punched paper, select the [Use preprinted/prepunched paper] check box in the [Printer Configuration] tab.

### **Cannot carry out Layout print for Excel sheets.**

In the printer properties dialog box, on the [Advanced Options] tab, select the [Increase auto-keep settings for applications] check box.

### **How can I make the Print mode change automatically according to the status of envelope selector?**

To automatically do single-sided printing when the envelope selector is set to the envelope position, on the [Printer Configuration] tab, select the [When the envelope selector is set to Envelope Mode, use uni-directional printing only] check box.

**How can I prevent ink transfer between printed sheets during duplex printing?**

On the [Printer Configuration] tab, in the [Sheet-dry Print Delay...] dialog box, change [Print delay time:].

**Ink smudges and characters are not properly formed when printing white text on a black background.**

In the [Print Quality] area, select [Quality priority], and then print.

---

## Checking the Consumables

---

If you cannot find anything wrong with the printer or printer driver, check the consumables.

**Is an old Print cartridge being used?**

Print cartridges should be used up before their expiry date, preferably within six months of being removed from their packaging.

**Is a genuine Print cartridge being used?**

Using a cartridge other than a genuine Print cartridge or using a cartridge refilled with ink will lower the print quality and could cause a breakdown. Use a genuine Print cartridge. See p.317 "Recommended Consumables".



## If a Message Appears during Installation

Message number 58 or 34 indicates the printer driver cannot be installed using Auto Run. Uninstall and then reinstall the printer driver.

## Error & Status Messages on the Control Panel

This section explains what the messages that appear on the control panel mean and what to do when a particular message appears.

Depending on the "Auto Continue" and "Env.Slctr.Alert" settings specified on the System menu, some of the following messages might not appear.

### Reference

- See p.178 "Specifying System Settings using the Control Panel (System Menu)"

## Control Panel Error Messages

### Cannot recover error page(s) / FormFeed to print remaining

When the printer resumes printing after the paper jam has been cleared, some page(s) has/have been missed.

To print the remaining pages after the missed page(s), press the [Form Feed] key. To delete the print job, press the [Job Reset] key.

See p.282 "Cannot Recover Error Page".

### Cannot use High Temp. / Power Off On

The temperature is abnormally high.

Switch the printer off and then on. If the message reappears, contact your service representative.

See p.278 "Out of Printable Temperature Range".

### Cannot use Low Temp. / Power Off On

The temperature is abnormally low.

Switch the printer off and then on. If the message reappears, contact your service representative.

See p.278 "Out of Printable Temperature Range".

### Change Setting Tray #

The size of paper in the selected tray does not match the specified paper size.

Load the tray with paper of the specified size, and then change the paper size setting for the tray on the control panel. Alternatively, press the [Form Feed] key, select a tray containing paper of the specified size, and then print. To cancel the print job, press the [Job Reset] key.

See p.254 "No Paper/Tray Not Detected (Tray 1)", p.256 "No Paper/Tray Not Detected (Tray 2/Tray 3)", p.258 "No Paper/Tray Not Detected (Bypass Tray)".

### Change Settings Tray #

The type of paper in the selected tray does not match the specified paper type.

Load the tray with paper of the specified type, and then change the paper type setting for the tray on the control panel. Alternatively, press the [Form Feed] key, select a tray containing paper of the specified type, and then print. To cancel the print job, press the [Job Reset] key.

See p.254 "No Paper/Tray Not Detected (Tray 1)", p.256 "No Paper/Tray Not Detected (Tray 2/Tray 3)", p.258 "No Paper/Tray Not Detected (Bypass Tray)".

### **Close Duplex Unit Cover**

The duplex unit cover is open. Close the duplex unit cover.

See p.267 "Cover Open".

### **Close Top Cover or Duplex Unit / Cover correctly**

The top cover, left cover, or duplex unit cover is open. Close the open cover, or reinstall/reset the duplex unit correctly.

See p.267 "Cover Open".

### **ERR(XXX) Power Off On / Call Service if error reoccurs**

An error has occurred.

Switch the printer off and then on. If the message reappears, contact your service representative.

See p.316 "Where to Inquire".

### **Energy Saver**

The printer is in Energy Saver mode. The printer is ready for use.

### **Envelop. Selector position error / Reset E.Selector or FormFeed**

The position of the envelope selector and the specified paper type do not match. This message appears also if the envelope selector is set to the  (rear) position while maintenance is carried out. Be sure to set the envelope selector to the right position.

See p.279 "Envelope Selector Position Mismatch".

### **Guide Board is open / Close the Guide Board**

The guide board is open. Close the guide board.

### **Hardware Problem Ethernet Board**

An error in the Ethernet port (ethernet board) network function has occurred.

See p.279 "Network Interface Error".

### **Ink Collector is not set / Set the Ink Collector Unit**

The ink collector unit has not been installed correctly. Reset the ink collector unit correctly.

See p.275 "Ink Collector Unit Not Detected".

### **Ink Collector Unit is full / Replace Ink Collector Unit**

The ink collector unit is full. Replace the ink collector unit.

See p.197 "Replacing an Ink Collector Unit".

### **Ink depleted**

The ink has run out. Change the indicated print cartridge.

See p.191 "Replacing a Print Cartridge".

### **Left Cover is open / Close the Left Cover**

The left cover is open. Close the left cover.

See p.267 "Cover Open".

### **Load Paper:Tray# or Form Feed**

The selected tray has run out of paper.

Reload the tray. Alternatively, press the [Form Feed] key, select a different tray, and then print. To cancel the print job, press the [Job Reset] key.

See p.254 "No Paper/Tray Not Detected (Tray 1)", p.256 "No Paper/Tray Not Detected (Tray 2/Tray 3)", p.258 "No Paper/Tray Not Detected (Bypass Tray)".

### **Low Ink**

The ink runs out. Make sure you have new print cartridges on hand.

See p.316 "Where to Inquire".

### **Maintenance failed**

Head cleaning or head flushing has failed.

The error is cleared when the following occur:

- The printer receives another print job
- Press the [#Enter] key

See p.282 "Maintenance Failed".

### **Maintenance in process...**

The printer is cleaning or flushing its print head. Wait a moment.

### **Offline**

The printer is offline. To print, put the printer online.

### **Open Front Cover / Replace Ink Crtg**

The ink in the indicated print cartridge has run out. Change the indicated print cartridge.

See p.191 "Replacing a Print Cartridge".

### **Panel Locked Cannot use**

You have pressed a locked key. Unlock the key.

See p.189 "Restricting Printer Functions".

**Paper Misfeed / Press Form Feed**

The printer failed to feed paper from the specified paper tray. Press the [Form Feed] key to feed the paper.  
See p.217 "Using the [Form Feed] Key to Remove Jammed Paper".

**Paper Misfeed Bypass Tray / Check Paper Press Form Feed**

Paper has jammed in the bypass tray. Clear the jam.  
See p.223 "Removing Paper Jammed in the Multi Bypass Tray (optional)".

**Paper Misfeed Remove all Rear / Units then remove misfeed**

Paper has jammed in the rear unit. Clear the jam.  
See p.222 "Removing Paper Jammed in the Rear Unit (optional)".

**Paper Misfeed Remove Duplex or / all Rear Units, remove misfeed**

Paper has jammed in the duplex unit or rear unit. Clear the jam.  
See p.234 "Removing Paper Jammed in the Duplex Unit".

**Paper Misfeed Remove Duplex or / Tray 2 Rear Unit, remove misfeed**

Paper has jammed in the duplex unit or Tray 2 rear unit. Clear the jam.  
See p.234 "Removing Paper Jammed in the Duplex Unit".

**Paper Misfeed Remove Rear Units / or Tray 2,3 then remove misfeed**

Paper has jammed in the rear unit or Tray 2, 3. Clear the jam.  
See p.222 "Removing Paper Jammed in the Rear Unit (optional)".

**Paper Misfeed Tray 1 / Remove Misfeed**

Paper has jammed in Tray 1. Clear the jam.  
See p.218 "Removing Paper Jammed in Tray 1".

**Paper Misfeed Tray 2 / Remove Misfeed**

Paper has jammed in Tray 2. Clear the jam.  
See p.220 "Removing Paper Jammed in Tray 2/Tray 3 (optional)".  
See p.222 "Removing Paper Jammed in the Rear Unit (optional)".

**Paper Misfeed Tray 3 / Remove Misfeed**

Paper has jammed in Tray 3. Clear the jam.  
See p.220 "Removing Paper Jammed in Tray 2/Tray 3 (optional)".  
See p.222 "Removing Paper Jammed in the Rear Unit (optional)".

**Prepare new Ink Collector Unit**

The ink collector unit is almost full. Make sure you have a new ink collector on hand.

If a print cartridge starts running out of ink when the ink collector unit is almost full, the alert indicator will flash and a message informing you of the cartridge's low ink level will appear on the control panel. To prevent job delay due to a full ink collector unit, always have a new ink collector unit ready.

See p.316 "Where to Inquire".

**Processing...**

The printer is printing.

**Ready**

The printer is able to print.

**Remove Misfeed Duplex Unit / Use Feed Wheel in Left Cover**

Paper has jammed in the duplex unit. Clear the jam.

See p.234 "Removing Paper Jammed in the Duplex Unit".

**Remove Misfeed Open Top Cover / Use Feed Wheel in Left Cover**

Paper has jammed under the top cover. Clear the jam.

See p.227 "Removing Paper Jammed under the Top Cover".

**Reset Bypass Tray correctly**

The bypass tray has not been installed correctly. Reset the bypass tray correctly. p.31 "Detaching and Reattaching the Multi Bypass Tray".

**Reset Cartridge**

No print cartridge has been installed. Install the print cartridge correctly.

See p.269 "Cover Open / Print Cartridge(s) Not Detected".

**Reset Duplex Unit correctly**

The duplex unit has not been installed correctly. Reset the duplex unit correctly.

See p.271 "Duplex Unit Not Detected".

**Reset Rear Unit correctly**

The rear unit has not been installed correctly. Reset the rear unit correctly.

See p.271 "Rear Unit of Optional Tray Not Detected".

**Resetting Job...**

The printer is reinitializing a print job.

Wait a moment.

**Right Front Cover is open / Close Right Front Cover**

The right front cover is open. Close the print cartridge cover.

See p.269 "Cover Open / Print Cartridge(s) Not Detected".

**Setting change...**

The printer is changing its settings. Wait a moment.

**Temp. alert Please wait...**

The printer is too hot or cold at start-up. Wait until "Ready" appears on the control panel.

**Waiting...**

Wait a moment.

**Note**

- If this does not eliminate the problem, contact your service representative.

## Status Monitor Errors

If an error occurs with the printer, Status Monitor displays an error message. Click [User Guide...] to display the page corresponding to the error where you can check how to solve the problem in more detail.

Depending on the "Auto Continue" and "Env.Slctr.Alert" settings specified on the System menu, some of the following messages might not appear.

### Reference

- See p.178 "Specifying System Settings using the Control Panel (System Menu)"

---

### Status Monitor Does Not Open

---

If the Status monitor does not open for a shared printer, the following questions should be addressed.

#### Are the share settings correct?

Check the share settings of the printer. The printer driver must also be installed on the client computer. See p.70 "Setting Up a Server" and p.71 "Setting Up a Client Computer".

## 7

---

### No Response from Printer

---

Follow the procedure below to check the port settings and the connection between the printer and computer.

1. Check that the power of the printer is on.
2. Make sure that the computer and printer are properly connected using a USB cable.
3. Open the printer properties dialog box.
4. Click the [Ports] tab.
5. Check that USB is selected in the [Print to the following port:] list.

### Note

- If you want to connect the printer to the network, check the operating environment, and then change the port setting. For details about configuring the port, see p.77 "Using the SmartDeviceMonitor for Client Port", p.78 "Using the Standard TCP/IP Port", and p.80 "Using the LPR Port".

---

### No Paper/Tray Not Detected (Tray 1)

---

Tray 1 is empty or the paper in it is not loaded properly. Do one of the following:

- Load the tray.
- Print by Form Feed (Change the tray).
- Cancel the print job.



## Reference

- To load the tray, see p.44 "Loading Paper".

## Printing by Form Feed

Press the [Form Feed] key, select the tray, and then print by Form Feed.

1. Press the [Form Feed] key.

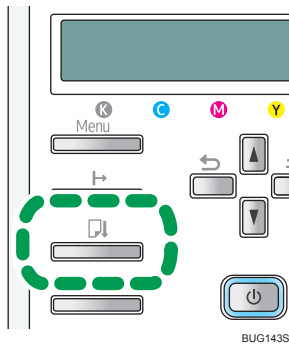

2. Press [▲] or [▼] key to select a paper tray, and then press the [#Enter] key.

```
Print: Tray 1 ?:  
A4 (210 x 297)
```

```
Print: Tray 1 ?:  
Plain Paper
```

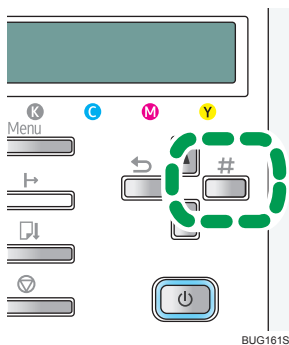

Printing starts.

## Canceling the Print Job

Cancel the print job.

1. Press the [Job Reset] key.

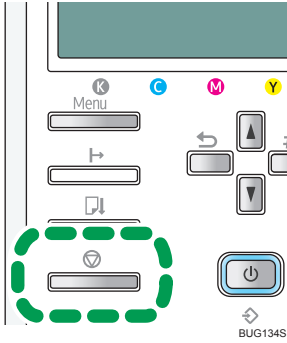

2. Press the [#Enter] key.

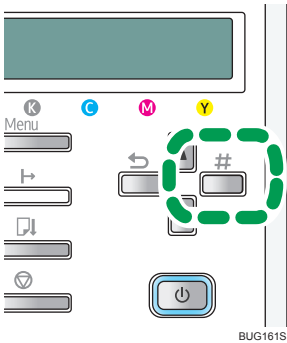

3. Press the [#Enter] key.

7

---

## No Paper/Tray Not Detected (Tray 2/Tray 3)

---

Tray 2/Tray 3 is empty or the paper in it is not loaded properly. Do one of the following:

- Load the tray.
- Print by Form Feed (Change the tray).
- Cancel the print job.

**E Reference**

- To load the tray, see p.44 "Loading Paper".

---

## Printing by Form Feed

---

Press the [Form Feed] key, select the tray, and then print by Form Feed.

### 1. Press the [Form Feed] key.

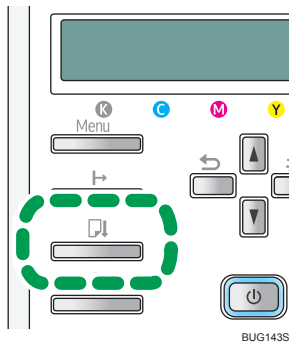

### 2. Press [▲] or [▼] key to select a paper tray, and then press the [#Enter] key.

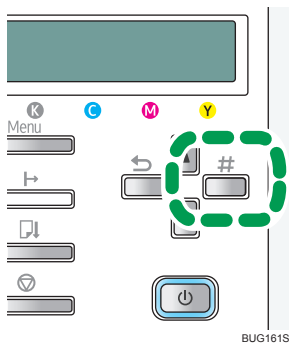
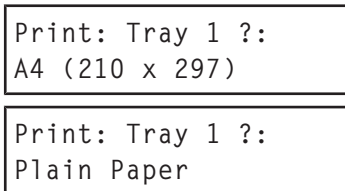

Printing starts.

## Canceling the Print Job

Cancel the print job.

**1. Press the [Job Reset] key.**

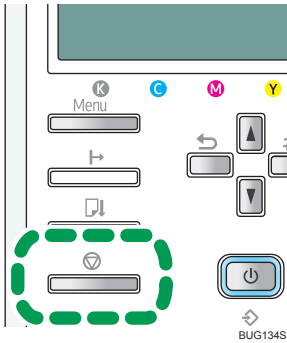

**2. Press the [#Enter] key.**

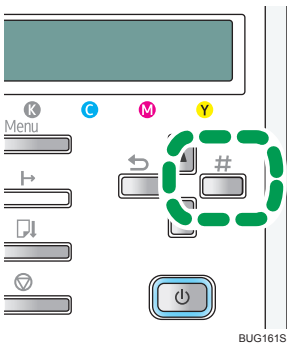

**3. Press the [#Enter] key.**

---

## No Paper/Tray Not Detected (Bypass Tray)

---

There is no paper in the bypass tray or the paper is not loaded properly. Do one of the following:

- Loading paper (Press the [#Enter] key).
- Cancel the print job.

**Reference**

- See p.31 "Detaching and Reattaching the Multi Bypass Tray".

## Loading Paper

---

Load paper in the bypass tray, and then press the [#Enter] key to begin printing.

**1. Load paper in the bypass tray.**

2. Press the [#Enter] key.

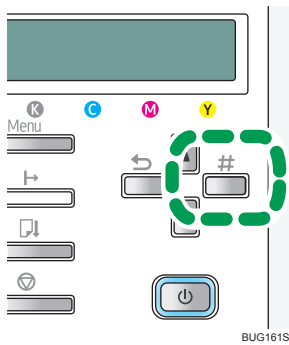

Printing starts.

**Reference**

- To load paper, see p.44 "Loading Paper".

## Canceling the Print Job

Cancel the print job.

1. Press the [Job Reset] key.

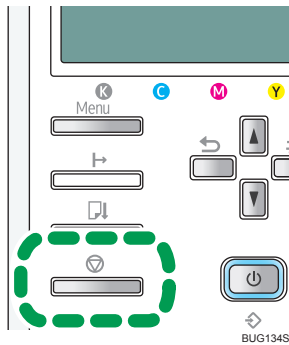

2. Press the [#Enter] key.

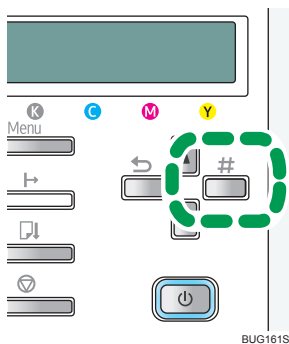

3. Press the [#Enter] key.

---

## Paper Size Mismatch/Paper Type Mismatch (Tray 1)

---

The tray is not loaded with paper of the correct size or type. Do one of the following:

- Change the paper settings.
- Print by Form Feed (Change the tray).
- Cancel the print job.

### Reference

- To change the paper settings, see p.94 "Specifying the Paper Settings using the Printer's Control Panel (Paper Input Menu)".

---

## Printing by Form Feed

---

Press the [Form Feed] key, select the tray, and then print by Form Feed.

1. Press the [Form Feed] key.

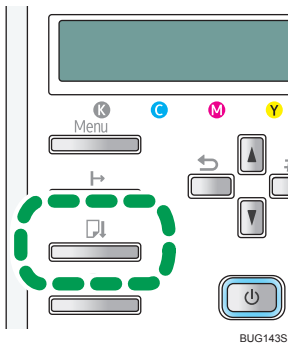

2. Press [▲] or [▼] key to select a paper tray, and then press the [#Enter] key.

```
Print: Tray 1 ?:  
A4 (210 x 297)
```

```
Print: Tray 1 ?:  
Plain Paper
```

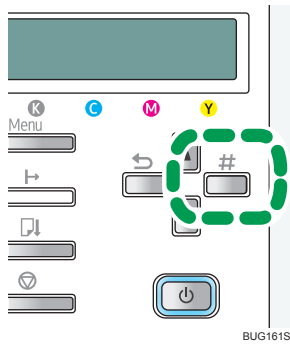

## Canceling the Print Job

Cancel the print job.

1. Press the [Job Reset] key.

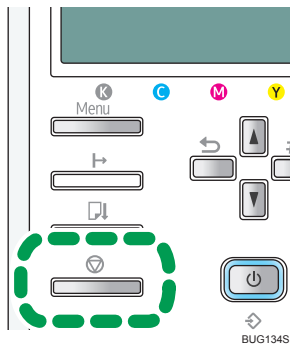

2. Press the [#Enter] key.

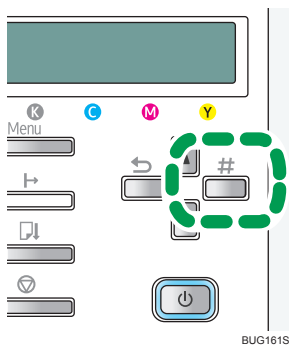

3. Press the [#Enter] key.

## Paper Size Mismatch/Paper Type Mismatch (Tray 2/Tray 3)

The tray is not loaded with paper of the correct size or type. Do one of the following:

- Change the paper settings.
- Print by Form Feed (Change the tray).
- Cancel the print job.

**Reference**

- To change the paper settings, see p.94 "Specifying the Paper Settings using the Printer's Control Panel (Paper Input Menu)".

## Printing by Form Feed

Press the [Form Feed] key, select the tray, and then print by Form Feed.

1. Press the [Form Feed] key.

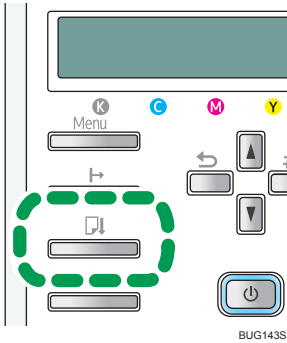

2. Press [▲] or [▼] key to select a paper tray, and then press the [#Enter] key.

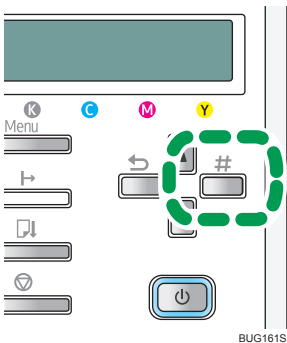
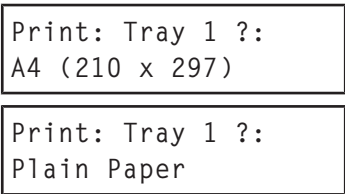



## Canceling the Print Job

Cancel the print job.

1. Press the [Job Reset] key.

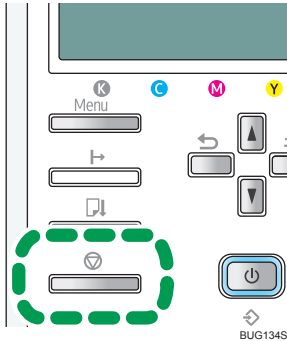

2. Press the [#Enter] key.

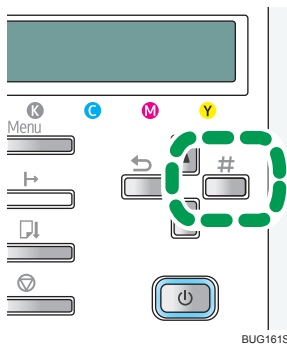

3. Press the [#Enter] key.

## Paper Size Mismatch/Paper Type Mismatch (Bypass Tray)

The tray is not loaded with paper of the correct size or type. Do one of the following:

- Change the paper settings.
- Print by Form Feed (Change the tray).
- Cancel the print job.

### Reference

- To change the paper settings, see p.94 "Specifying the Paper Settings using the Printer's Control Panel (Paper Input Menu)".

## Printing by Form Feed

Press the [Form Feed] key, select the tray, and then print by Form Feed.

1. Press the [Form Feed] key.

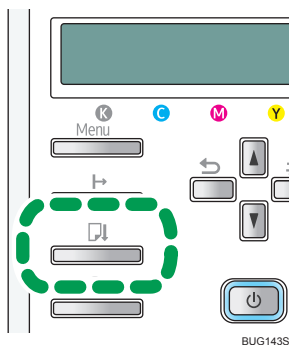

2. Press [▲] or [▼] key to select a paper tray, and then press the [#Enter] key.

```
Print: Tray 1 ?:  
A4 (210 x 297)
```

```
Print: Tray 1 ?:  
Plain Paper
```

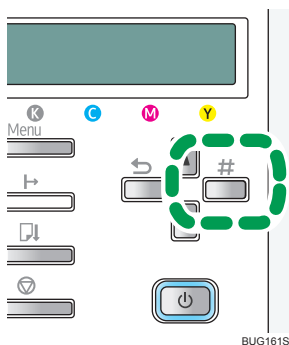

## Canceling the Print Job

Cancel the print job.

### 1. Press the [Job Reset] key.

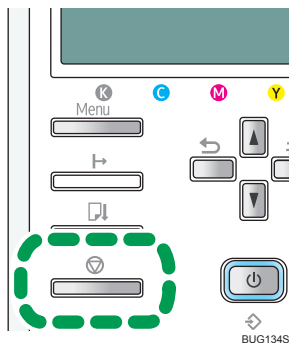

### 2. Press the [#Enter] key.

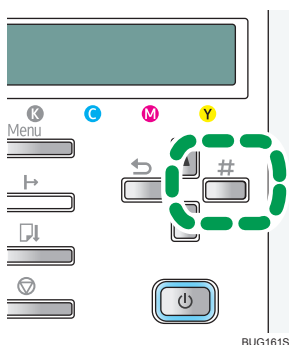

### 3. Press the [#Enter] key.

## Paper Size Mismatch/Paper Type Mismatch (Auto Tray Select)

The automatically detected tray is not loaded with paper of the correct size or type. Do one of the following:

- Change the paper settings.
- Print by Form Feed (Change the tray).
- Cancel the print job.

### **E** Reference

- To change the paper settings, see p.94 "Specifying the Paper Settings using the Printer's Control Panel (Paper Input Menu)".

## Printing by Form Feed

Press the [Form Feed] key, select the tray, and then print by Form Feed.

**1. Press the [Form Feed] key.**

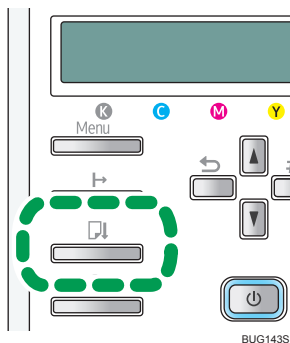

**2. Press [▲] or [▼] key to select a paper tray, and then press the [#Enter] key.**

```
Print: Tray 1 ?:  
A4 (210 x 297)
```

```
Print: Tray 1 ?:  
Plain Paper
```

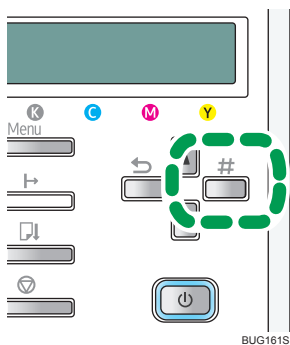

7

---

### Canceling the Print Job

Cancel the print job.

### 1. Press the [Job Reset] key.

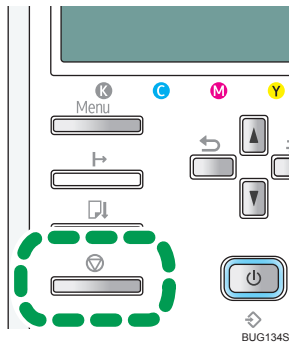

### 2. Press the [#Enter] key.

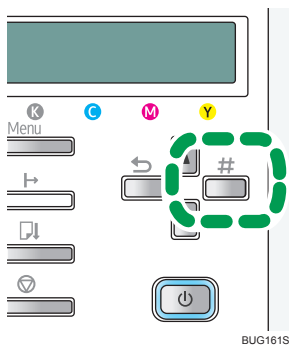

### 3. Press the [#Enter] key.

---

## Cover Open

---

A cover is open. Make sure all covers are fully closed.

If the cover is already closed, open and then reclose it.

Follow the procedure below to close the cover.

1. Close the cover.

Top cover

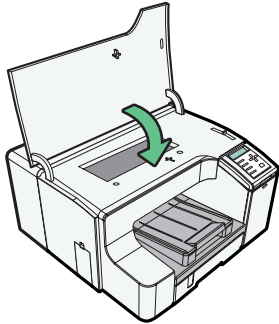

BUG182S

Left cover

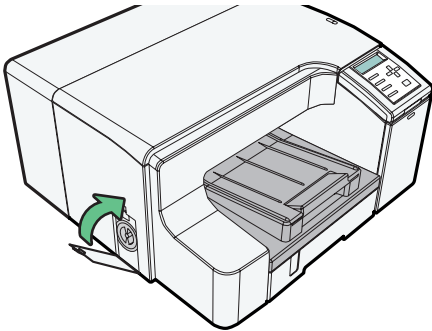

BUG156S

Duplex unit cover

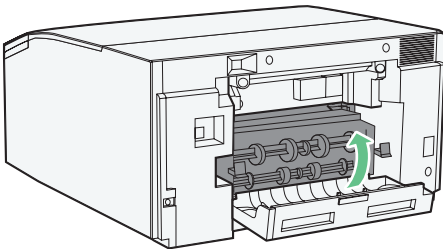

BUG159S

If the bypass tray is attached to the printer, switch the printer off and detach the bypass tray. Check that the duplex unit is correctly attached and the duplex unit cover is closed.

**Note**

- There is a guide board in the recess behind the duplex unit. If the guide board is open, close it.

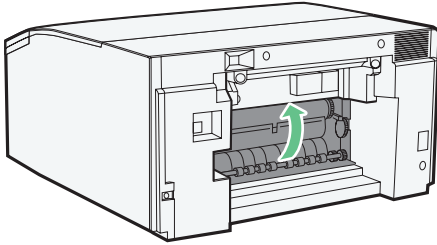

BUG142S

### Reference

- p.31 "Detaching and Reattaching the Multi Bypass Tray"
- p.20 "Guide to Components"

## Cover Open / Print Cartridge(s) Not Detected

The right front cover is open. Close the right front cover. Alternatively, the print cartridges are not installed or are installed incorrectly. Install the print cartridges correctly.

If the cover is open:

1. Close the right front cover.

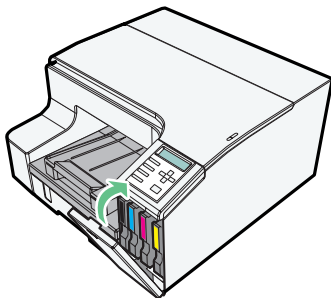

BUG115S

If the print cartridges are not installed or are installed incorrectly:

1. While pressing the recessed area (①) of the right front cover, open the cover (②).

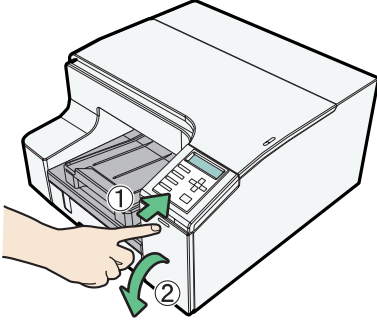

BUG113S

2. Push in the cartridge.

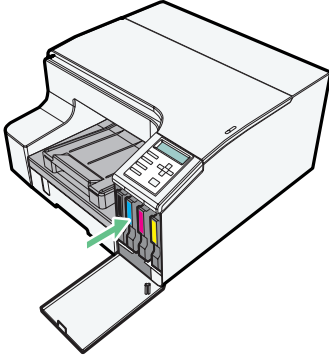

BUG141S

3. Close the right front cover.

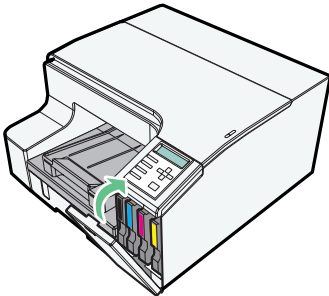

BUG115S

**Note**

- If the error persists, remove the print cartridge and then reinstall it. Do this once only.
- If there is a problem with the print cartridge, try installing a new cartridge.



---

## Duplex Unit Not Detected

---

The duplex unit is not attached correctly. Follow the procedure below to attach the duplex unit correctly.

### ★ Important

- If the bypass tray is attached to the printer, switch the printer off and detach the bypass tray.
1. Without pressing the catches on its sides, push the duplex unit all the way in until it clicks into place.

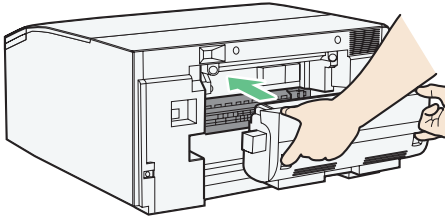

BUG155S

### 📖 Reference

- p.31 "Detaching and Reattaching the Multi Bypass Tray"

7

---

## Rear Unit of Optional Tray Not Detected

---

The rear unit is not attached correctly. Follow the procedure below to attach the rear unit correctly.

1. Holding the rear handle, attach the rear unit.

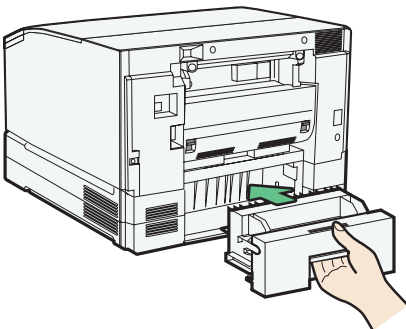

BUG242S

## Cartridge Almost Empty

One of the print cartridges is almost empty. Check which color print cartridge will soon have to be replaced, and then have a new cartridge handy.

### Checking ink colors

- Checking using the Status monitor



7

The illustration above indicates the cyan print cartridge is almost empty.

### Checking the cartridge replacement indicators of the printer control panel

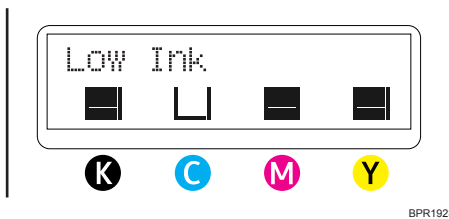

The illustration above indicates the cyan print cartridge is almost empty.

#### Note

- The amount of remaining ink shown in the cartridge replacement indicator is for reference only and may differ from the actual amount. Also, cartridges can become empty without a low ink warning appearing.
- From left to right, the cartridge replacement indicators display the status of the black (K), cyan (C), magenta (M), and yellow (Y) Print cartridges.
- With glossy paper, if you print an image that needs a lot of ink, the printer may stop printing before the print is finished. An example of such an image is one containing a single large area of solid color, or one made up almost entirely of a few such areas.

- Do not carry out head cleaning or head flushing. If you do, the ink may run out.
- If you turn the power off and then back on, the printer will send the ink in the print cartridge to the printer. During this, the ink in the print cartridge may run out.

### Reference

- p.109 "Using the Status Monitor"

## Cartridge Empty

The ink is completely depleted. Printing cannot be performed. Replace the Print cartridge.

### Checking ink colors

- Checking using the Status monitor

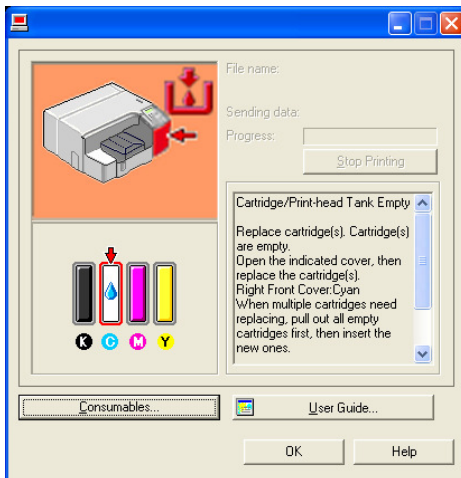

The illustration above indicates the cyan Print cartridge has completely run out.

### Checking the cartridge replacement indicators of the printer control panel

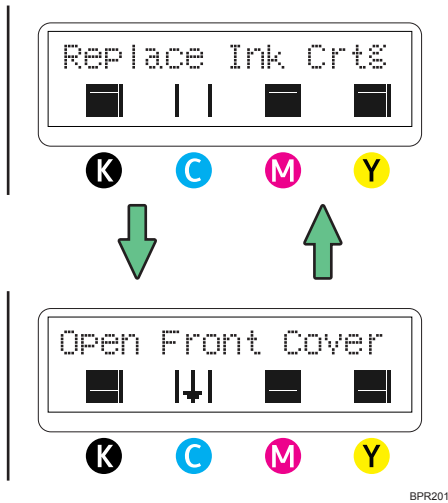

The illustration above indicates the control panel is indicating that the cyan Print cartridge has completely run out.

#### ↓ Note

- From left to right, the cartridge replacement indicators display the status of the black (K), cyan (C), magenta (M), and yellow (Y) Print cartridges.
- Under this condition, the printer cannot carry out head cleaning or head flushing.
- If the ink runs out during printing, the printer may eject blank or partially printed sheets.

#### 📖 Reference

- p.191 "Replacing a Print Cartridge"
- p.109 "Using the Status Monitor"

---

## Used Cartridge

---

The installed print cartridge has run out of ink. Printing cannot be performed. Replace the Print cartridge.

## Checking the cartridge replacement indicators of the printer control panel

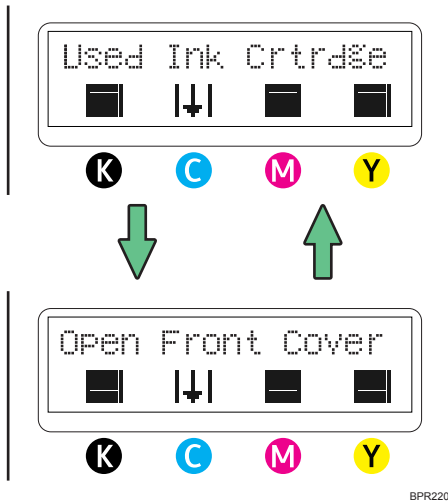

The illustration above indicates the cyan print cartridge is empty.

### ↓ Note

- Under this condition, the printer cannot carry out head cleaning or head flushing.
- From left to right, the cartridge replacement indicators display the status of the black (K), cyan (C), magenta (M), and yellow (Y) Print cartridges.
- Cartridges that are no longer usable for printing reserve a small quantity of ink for maintenance usage. Make sure you do not install an empty print cartridge by mistake.
- Print cartridges should be used up before their expiry date, preferably within six months of being removed from their packaging.

### 📖 Reference

- p.191 "Replacing a Print Cartridge"
- p.109 "Using the Status Monitor"

## Ink Collector Unit Not Detected

The ink collector unit is not attached correctly. Follow the procedure below to attach the ink collector unit correctly.

1. While pressing the recessed area (①) of the right front cover, open the cover (②).

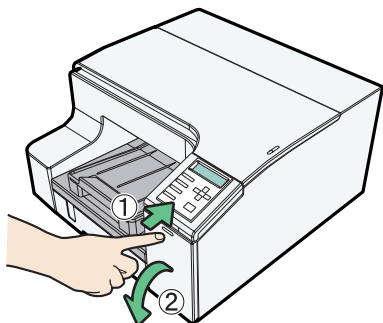

BUG113S

2. Attach the ink collector unit by pushing it in until it clicks. Take care not to spill the ink.  
Remove the ink collector unit only when necessary.

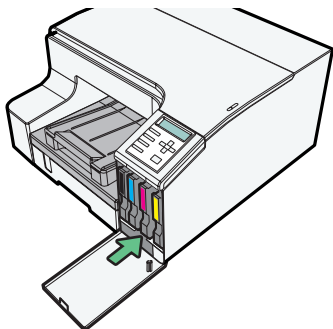

BUG162S

3. Close the right front cover.

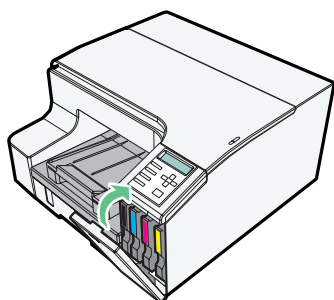

BUG115S

If the message reappears, contact your service representative.

**Reference**

- p.316 "Where to Inquire"

---

## Ink Collector Unit Almost Full

---

The ink collector unit is almost full. Have a new ink collector unit handy.

### Checking using the printer's control panel

Prepare new Ink  
Collector Unit

#### ↓ Note

- If a print cartridge starts running out of ink when the ink collector unit is almost full, the alert indicator will flash and a message informing you of the cartridge's low ink level will appear on the control panel. To prevent job delay due to a full ink collector unit, always have a new ink collector unit ready.

#### 📖 Reference

- Where to Inquire

---

## Ink Collector Unit Full

---

The ink collector unit is full. To print, you must replace the ink collector unit.

### Checking using the printer's control panel

Ink Collector  
Unit is full

Replace Ink  
Collector Unit

#### 📖 Reference

- p.197 "Replacing an Ink Collector Unit"

---

## Used Ink Collector Unit

---

A used ink collector unit has been installed. To print, you must replace the ink collector unit.

### Checking using the printer's control panel

Used Ink Collect  
Unit is set

#### 📖 Reference

- Replacing an Ink Collector Unit

## Out of Printable Temperature Range

Follow the procedure below to relocate the printer when the temperature inside the printer is inappropriate, extremely high or low, for printing.

### 1. Turn the printer off.

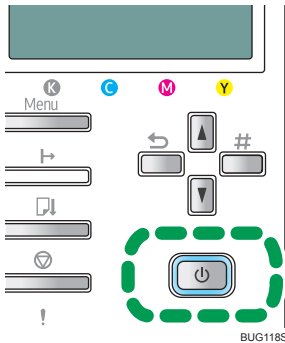

### 2. Place the printer in a 10 to 32°C (50 to 89.6°F) environment.

### 3. Turn the printer on.

#### ↓ Note

- If humidity is more than 54%, the high end of the appropriate temperature range will be lower than usual.
- Even after the power is turned on, the printer may remain in the standby mode until it acclimates to the room temperature. If this happens, wait until the [Power] key stops blinking and stays lit.

#### 📖 Reference

- For details about what conditions the printer can be used under (ambient temperature and humidity range), see p.35 "Checking the Computer and Installation Area".
- See p.201 "Moving".

## Printer Error

An error has occurred in the printer. Turn the power off once, and then turn it back on.

#### ↓ Note

- If the printer is relocated from a cold area to a warm area or the printer is placed in a room where the temperature varies greatly, condensation may form inside the printer causing errors. If this happens, perform the decondensation procedure.

#### 📖 Reference

- For details about de-condensation, see p.176 "De-condensation".



- If the error still does not clear after the printer acclimates to room temperature and the power is turned back on, contact your sales or service representative.

## Network Interface Error

An error in the Ethernet port network function has occurred. Do the following:

### 1. Turn the printer off.

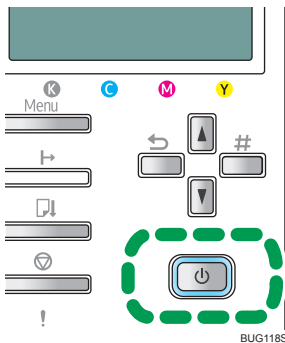

### 2. Turn the printer on.

If the message reappears, contact your service representative.

#### Reference

- p.316 "Where to Inquire"

## Envelope Selector Position Mismatch

The envelope selector is in the wrong position or the printer driver settings are wrong. Set the envelope selector to the right position or change the printer driver settings. Alternatively, press the [Form Feed] key, select a tray containing paper of the required size, and then print. To cancel the print job, press the [Job Reset] key.

## Check the position of the envelope selector

1. For envelopes, set the lever to the rear position ; for everything else, set the lever to the forward position .

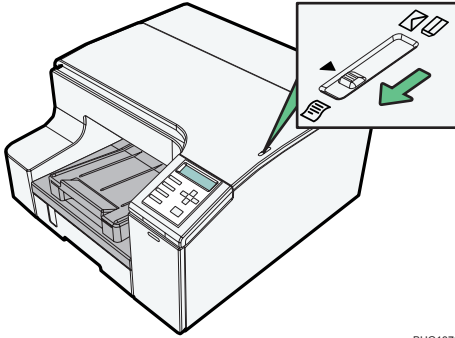

BUG137S

## Check the printer driver settings

1. In the application, open the printer properties dialog box.
2. Click the [Setup] tab.
3. Check the [Paper type:] setting.

Select the paper type from the [Paper type:] dropdown list. For envelopes, select [Envelope].

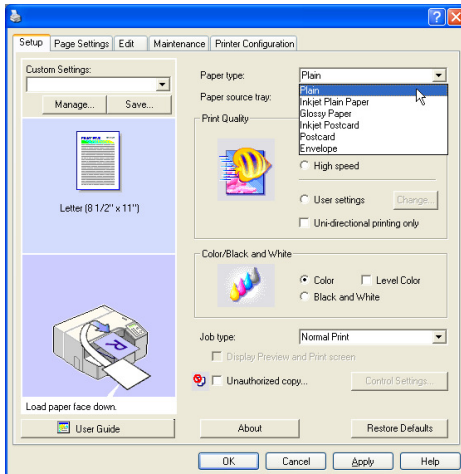

4. Click [OK].

## Printing by Form Feed

Press the [Form Feed] key, and then print.

### 1. Press the [Form Feed] key.

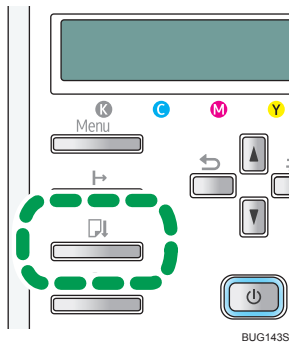

### 2. Press the [#Enter] key.

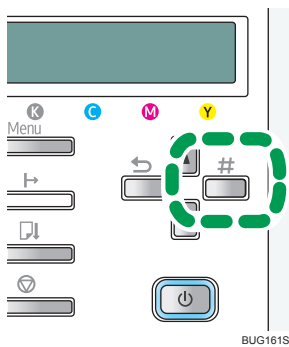

## Canceling the Print Job

Cancel the print job.

### 1. Press the [Job Reset] key.

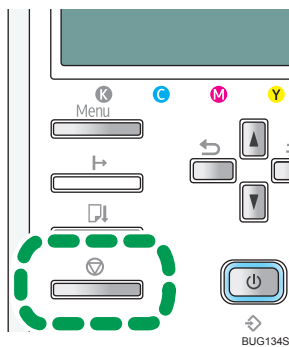

**2. Press the [#Enter] key.**

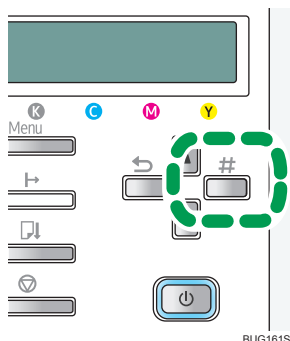

**3. Press the [#Enter] key.**

---

## Maintenance Failed

---

Head cleaning or head flushing has failed.

The error is cleared when the following occur:

- The printer receives another print job
- Press the [#Enter] key

7

---

## Cannot Recover Error Page

---

When the printer resumes printing after a paper jam has been cleared, some pages might be missing from the print job. If this happens, do one of the following:

- Print by Form Feed (The printer prints the remaining pages following the missed page[s])
- Cancel the print job.

---

## Printing by Form Feed

---

Press the [Form Feed] key, and then print.

### 1. Press the [Form Feed] key.

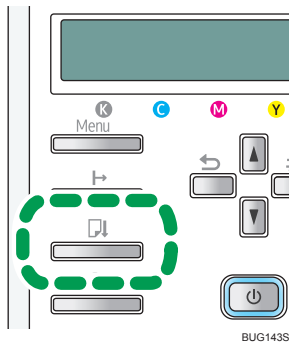

### 2. Press the [#Enter] key.

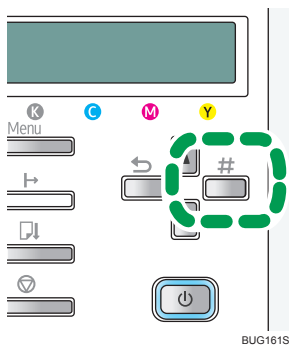

## Canceling the Print Job

Cancel the print job.

### 1. Press the [Job Reset] key.

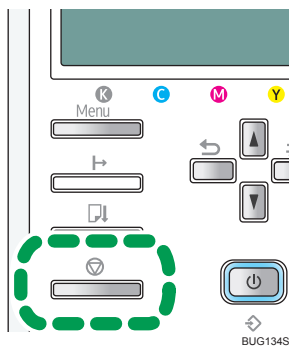

**2. Press the [#Enter] key.**

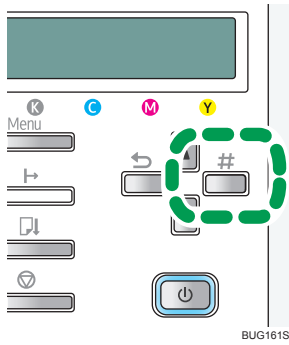

**3. Press the [#Enter] key.**

# 8. Appendix

---

## Updating the Firmware

To update the printer and network interface board firmware, download the latest firmware from the website and installing it.

### ↓ Note

- To check the current firmware version, print the system configuration page from the [List/Test Print] menu.

### 📖 Reference

- p.65 "Checking the Printer Status and Settings using the Printer's Control Panel (List/Test Print Menu)"

## Checking the Current Printer Driver Version

Follow the procedure below to check the version of the printer driver currently installed.

1. **Open the printer properties dialog box.**
2. **Click the [Setup] tab.**
3. **Click [About].**

The [About] dialog box appears.

4. **Check the version.**
5. **Click [OK].**



# Software on the CD-ROM

This section describes the CD-ROM supplied with the printer.

## Files

The following is a list of the files on the CD-ROM.

| File Name   |
|---|
| SETUP.EXE   |
| RPCS Raster Printer Driver for Windows 2000/XP/Vista and Windows Server 2003/2008 |
| PCL 5c Printer Driver for Windows 2000/XP/Vista and Windows Server 2003/2008      |
| PCL 6 Printer Driver for Windows 2000/XP/Vista and Windows Server 2003/2008       |
| SmartDeviceMonitor for Client   |
| ICM Color Profiles for Printer  |
| Manuals (HTML files)  |

## RPCS Raster Printer Drivers

8

This section gives the file locations of the different RPCS raster printer drivers and their system requirements.

### File Location

The drivers are in the following folders on the supplied CD-ROM.

- RPCS raster printer driver for Windows 2000/XP/Vista and Windows Server 2003/2008

**Drivers\Rpcs\_r\XP\_VISTA\DISK1**

### System Requirements for the Printer Drivers

- Computer  
PC/AT-compatible computer with USB interface
- Operating Systems  
Windows 2000/XP/Vista or Windows Server 2003/2008
- Display Resolution  
Minimum SVGA 800 × 600 pixels

**Note**

- The printer drivers do not support clustering technology under Windows 2000 and Windows Server 2003/2008.
- For details about using the printer driver, see the printer driver Help.

---

## PCL Printer Drivers

---

This section gives the file locations of the different PCL 5c printer drivers and their system requirements. These drivers allow your computer to communicate with this printer via a printer language.

### File Location

The Drivers are in the following folders on the supplied CD-ROM.

- PCL 5c printer driver for Windows 2000/XP/Vista and Windows Server 2003/2008  
`Drivers\Pc15c\XP_VISTA\xxxx\disk1`
- PCL 6 printer driver for Windows 2000/XP/Vista and Windows Server 2003/2008  
`Drivers\Pc16\XP_VISTA\xxxx\disk1`

### System Requirements for the Printer Drivers

- Computer  
PC/AT-compatible computer with USB interface
- Operating Systems  
Windows 2000/XP/Vista or Windows Server 2003/2008
- Display Resolution  
Minimum SVGA 800 × 600 pixels

**Note**

- "xxxx" in the file location will be the name of the printer driver's supported language.
- The printer drivers do not support clustering technology under Windows 2000 and Windows Server 2003/2008.
- For details about using the printer driver, see the printer driver Help.

---

## SmartDeviceMonitor for Client

---

This section explains the functions and location of SmartDeviceMonitor for Client.

SmartDeviceMonitor for Client is software with the following functions. It is recommended that you install it on any computer you wish to use the printer with.

- Under Windows 2000/XP/Vista, and Windows Server 2003/2008, you can print over a peer-to-peer TCP/IP network.
- You can monitor the printer status over a TCP/IP network.

**File Location**

SmartDeviceMonitor for Client is in the following folder on the supplied CD-ROM.

**Network\Devmon\Client\Disk1**

**Note**

- See "p.110 "Using SmartDeviceMonitor for Client"", or the SmartDeviceMonitor for Client Help.

**Reference**

- For details about installing SmartDeviceMonitor for Client, see p.77 "Using the SmartDeviceMonitor for Client Port".

---

**Manuals (HTML files)**

---

This section gives the location of the manuals.

**File Location**

The manuals are in the following folders on the supplied CD-ROM.

**MANUAL\_HTML**

# Cautions to Take When Using in a Network

---

## Using DHCP

---

This printer can be used in a DHCP environment. In a WINS server environment, the printer name can simultaneously be registered with a WINS server.

### ↓ Note

- Supported DHCP server operating systems are: Windows 2000 Server, Windows Server 2003, Windows Server 2008, and UNIX standard.
- The IP address acquired from DHCP can be checked on the configuration page. For details about printing a configuration page, see "Checking the Printer Status and Settings using the Printer's Control Panel (List/Test Print Menu)".
- When there are multiple DHCP servers, make the same reservation for all. This printer uses information from the DHCP server that responds first.

### 📖 Reference

- p.65 "Checking the Printer Status and Settings using the Printer's Control Panel (List/Test Print Menu)"

# Electromagnetic Interference

If another electronic device is placed next to the printer, each will influence the other negatively. In the case of a television or radio, noise may be generated. If this happens, do the following:

- Move the television or radio as far as possible from the printer.
- Change the position of the antenna of the television or radio.
- Use a different wall outlet on a different circuit.

# Specifications

Specifications of the printer and options are listed.

## Printer Body

### Print speed

Measurements according to the manufacturer's measurement system

Black draft: 30.0 ppm

Color draft: 30.0 ppm

Depending on the operating environment, printing may take longer than normal.

### Print direction

Supports bidirectional, minimum distance printing

### Print resolution

Max 1200 × 1200 dpi equivalent

### Nozzles

Black: 192 nozzles

Cyan, magenta, and yellow: 192 nozzles per color

### Paper sizes (Tray 1 : standard)

Standard paper size: A4<sup>□</sup>, A5<sup>□</sup>, A6<sup>□</sup>, B5 JIS<sup>□</sup>, Letter (8 1/2" × 11")<sup>□</sup>, Legal(8 1/2" × 14")<sup>□</sup>, 5 1/2" × 8 1/2"<sup>□</sup>, Executive (7 1/4" × 10 1/2")<sup>□</sup>, 8" × 13"<sup>□</sup>, 8 1/2" × 13"<sup>□</sup>, 8 1/4" × 13"<sup>□</sup>, 16K<sup>□</sup>, Com10 Envelope (4 1/8" × 9 1/2")<sup>□</sup>, Monarch Envelope (3 7/8" × 7 1/2")<sup>□</sup>, C6 Envelope (114 × 162 mm)<sup>□</sup>, C5 Envelope (162 × 229 mm)<sup>□</sup>, DL Envelope (110 × 220 mm)<sup>□</sup>

Custom paper sizes: 139.7-356 mm (5.50-14.01 inch) (Vertical) × 88-216 mm (3.46-8.50 inch) (Horizontal)

### Paper sizes (Duplex Unit)

Standard paper size: A4<sup>□</sup>, A5<sup>□</sup>, A6<sup>□</sup>, B5 JIS<sup>□</sup>, Letter (8 1/2" × 11")<sup>□</sup>, 5 1/2" × 8 1/2"<sup>□</sup>, Executive (7 1/4" × 10 1/2")<sup>□</sup>, 16K<sup>□</sup>

### Paper type

Plain paper

Recycled paper

Color paper

Inkjet plain paper

Glossy paper (Duplex printing is not supported.)

Envelope (Duplex printing is not supported.)

**Paper weight**

Tray 1/ optional tray: 60-157 g/m<sup>2</sup> (16.0-42.0 lb.)

**Paper capacity**

Tray 1: 250 sheets

**Maximum paper capacity**

1350 sheets (with the optional tray installed)

**Output ramp capacity**

100 sheets

The capacity may be less depending on the images printed.

**Power source**

100-120V: 50/60Hz 1.2A (when fully equipped)

220-240V: 50/60Hz 0.6A (when fully equipped)

**Power consumption**

Average power consumption while printing:

38 W or less (not including options)

Energy Saver mode:

less than 3.4 W

To avoid any power consumption, disconnect the power plug from the wall outlet.

(Unplug the power plug only after making sure the [Power] key indicator is off.)

**Operating environment**

Temperature: 10 to 32°C (50 to 89.6°F)

Humidity: 15-80% RH (maximum wet-bulb temperature: 25°C (77°F))

Printing may stop to protect the printer for conditions outside those described above.

**Storage environment**

Temperature: 1 to 40°C (33.8 to 104°F)

Humidity: 5-80% RH

**External dimensions**

(W × D × H) 509 × 485 × 263 mm (20.0 × 19.1 × 10.4 inches)

(W × D × H) 509 × 707 × 450 mm (20.0 × 27.8 × 17.7 inches) (when fully equipped)

**Weight**

Approximately 15.5 kg (34.2 lb.) (printer body with consumables)

Approximately 29.9 kg (65.9 lb.) (when fully equipped)

**Noise emission****Sound Power Level**

|                 | Main unit only   |
|-----------------|--|
| During Printing | Quality priority : 62.7 dB(A) or less<br>Speed priority : 66.7 dB(A) or less |
| Standby         | 40 dB(A) or less   |

**Sound Pressure Level**

|                 | Main unit only   |
|-----------------|--|
| During Printing | Quality priority : 56.7 dB(A) or less<br>Speed priority : 60.7 dB(A) or less |
| Standby         | 34 dB(A) or less   |

**Interface**

USB 2.0 high speed

Ethernet (10BASE-T, 100BASE-TX)

**Printer language**

RPCS Raster, PCL

8

**Option (Paper Feed Unit)****Paper Feed Unit Type TK1110****Paper sizes**

A4☐, A5☐, A6☐, B5 JIS☐, Letter (8<sup>1</sup>/<sub>2</sub>" × 11")☐, Legal (8<sup>1</sup>/<sub>2</sub>" × 14")☐, Executive (7<sup>1</sup>/<sub>4</sub>" × 10<sup>1</sup>/<sub>2</sub>")☐, 8" × 13"☐, 8<sup>1</sup>/<sub>2</sub>" × 13"☐, 8<sup>1</sup>/<sub>4</sub>" × 13"☐, 16K☐

Custom paper sizes: 148-356 mm (5.83-14.01 inch) (Vertical) × 105-216 mm (4.14-8.50 inch) (Horizontal)

**Paper type**

Plain paper

Recycled paper

Color paper

Inkjet plain paper



Glossy paper

**Paper weight**

60-105 g/m<sup>2</sup> (16.0-28.0 lb.)

**Paper capacity**

500 sheets

## Option (Bypass tray)

### Multi Bypass Tray Type BY1000

**Paper sizes**

A4<sup>□</sup>, A5<sup>□</sup>, A6<sup>□</sup>, B5 JIS<sup>□</sup>, Letter (8<sup>1</sup>/<sub>2</sub>" × 11")<sup>□</sup>, Legal (8<sup>1</sup>/<sub>2</sub>" × 14")<sup>□</sup>, 5<sup>1</sup>/<sub>2</sub>" × 8<sup>1</sup>/<sub>2</sub>"<sup>□</sup>, Executive (7<sup>1</sup>/<sub>4</sub>" × 10<sup>1</sup>/<sub>2</sub>" )<sup>□</sup>, 8" × 13"<sup>□</sup>, 8<sup>1</sup>/<sub>2</sub>" × 13"<sup>□</sup>, 8<sup>1</sup>/<sub>4</sub>" × 13"<sup>□</sup>, 16K<sup>□</sup>, Com10 Envelope (4<sup>1</sup>/<sub>8</sub>" × 9<sup>1</sup>/<sub>2</sub>" )<sup>□</sup>, Monarch Envelope (3<sup>7</sup>/<sub>8</sub>" × 7<sup>1</sup>/<sub>2</sub>" )<sup>□</sup>, C6 Envelope (114 × 162 mm)<sup>□</sup>, C5 Envelope (162 × 229 mm)<sup>□</sup>, DL Envelope (110 × 220 mm)<sup>□</sup>

Custom paper sizes: 127-1295.4 mm (5-51 inch) (Vertical) × 55-216 mm (2.17-8.50 inch) (Horizontal)

**Paper type**

Plain paper

Recycled paper

Color paper

Inkjet plain paper

Glossy paper

Envelope

Thick

**Paper weight**

52-255 g/m<sup>2</sup> (14.0-68.0 lb.)

**Paper capacity**

100

**Note**

- Under the PCL driver, the available custom size is 139.7-355.9 mm (5.50-14.01 inch) (Vertical) × 55.0-216.0 mm (2.17-8.50 inch) (Horizontal).

# List of Printer Driver Functions (Windows/Macintosh)

The following tables list the functions available under Mac OS X and their Windows printer driver equivalents.

## Paper source tray

| Windows          | Mac OS X         |
|------------------|------------------|
| Tray 1           | Tray 1           |
| Tray 2           | Tray 2           |
| Tray 3           | Tray 3           |
| Bypass Tray      | Bypass Tray      |
| Auto Tray Select | Auto Tray Select |

## Paper type

| Windows            | Mac OS X           |
|--------------------|--------------------|
| Plain              | Plain              |
| Inkjet Plain Paper | Inkjet Plain Paper |
| Glossy Paper       | Glossy Paper       |
| Inkjet Postcard    | Inkjet Postcard    |
| Postcard           | Postcard           |
| Envelope           | Envelope           |
| Thick              | Thick              |

## Original size

| Windows | Mac OS X |
|---------|----------|
| A0      | -        |
| A1      | -        |
| A2      | -        |
| A3      | -        |

| Windows   | Mac OS X  |
|---|---|
| A4  | A4  |
| A5  | A5  |
| A6  | A6  |
| B1 JIS  | -   |
| B2 JIS  | -   |
| B3 JIS  | -   |
| B4 JIS  | -   |
| B5 JIS  | B5 JIS  |
| B6 JIS  | B6 JIS  |
| Letter  | Letter (US Letter)  |
| Legal   | Legal (US Legal)  |
| 12" x 18"   | -   |
| 5 <sup>1</sup> / <sub>2</sub> " x 8 <sup>1</sup> / <sub>2</sub> " | 5 <sup>1</sup> / <sub>2</sub> " x 8 <sup>1</sup> / <sub>2</sub> " |
| 11" x 17"   | -   |
| Reply-paid Postcard   | Reply-paid Postcard   |
| Executive   | Executive   |
| 8" x 13"  | F/GL  |
| 8 <sup>1</sup> / <sub>2</sub> " x 13"                             | Foolscap  |
| 8 <sup>1</sup> / <sub>4</sub> " x 13"                             | Folio   |
| 8K  | -   |
| 16K   | 16K   |
| Com10 Env.  | Com10 Env.  |
| Monarch Env.  | Monarch Env.  |
| C6 Env.   | C6 Env. (C6 Envelope)   |
| C5 Env.   | C5 Env. (C5 Envelope)   |

| Windows           | Mac OS X              |
|-------------------|-----------------------|
| DL Env.           | DL Env. (DL Envelope) |
| Custom Paper Size | Custom Paper Size     |

The sizes shown in the brackets ( ) for Mac OS X are the sizes shown on the printer driver.

### Printout paper size

| Windows   | Mac OS X  |
|---|---|
| A4  | A4  |
| A5  | A5  |
| A6  | A6  |
| B5 JIS  | B5 JIS  |
| B6 JIS  | B6 JIS  |
| Letter  | Letter (US Letter)  |
| Legal   | Legal (US Legal)  |
| 5 <sup>1</sup> / <sub>2</sub> " × 8 <sup>1</sup> / <sub>2</sub> " | 5 <sup>1</sup> / <sub>2</sub> " × 8 <sup>1</sup> / <sub>2</sub> " |
| Reply-paid Postcard   | Reply-paid Postcard   |
| Executive   | Executive   |
| 8" × 13"  | F/GL  |
| 8 <sup>1</sup> / <sub>2</sub> " × 13"                             | Foolscap  |
| 8 <sup>1</sup> / <sub>4</sub> " × 13"                             | Folio   |
| 16K   | 16K   |
| Com10 Env.  | Com10 Env.  |
| Monarch Env.  | Monarch Env.  |
| C6 Env.   | C6 Env. (C6 Envelope)   |
| C5 Env.   | C5 Env. (C5 Envelope)   |
| DL Env.   | DL Env. (DL Envelope)   |

| Windows     | Mac OS X    |
|-------------|-------------|
| Custom Size | Custom Size |

The sizes shown in the brackets ( ) for Mac OS X are the sizes shown on the printer driver.

### Original orientation

| Windows   | Mac OS X   |
|-----------|--|
| Portrait  | Portrait (This function is provided by the operating system.)  |
| Landscape | Landscape (This function is provided by the operating system.) |

### Collate

| Windows   | Mac OS X   |
|-----------|--|
| Available | Available (This function is provided by the operating system.) |

### Reverse order printing

| Windows   | Mac OS X   |
|-----------|--|
| Available | Available (This function is provided by the operating system.) |

### Rotate by 180 degrees

| Windows   | Mac OS X   |
|-----------|--|
| Available | Available (This function is provided by the operating system.) |

### Centering

| Windows   | Mac OS X    |
|-----------|-------------|
| Available | Unavailable |

### Job type

| Windows      | Mac OS X    |
|--------------|-------------|
| Normal Print | Unavailable |

| Windows                 | Mac OS X |
|-------------------------|----------|
| Send to Job Binding...  |          |
| Save as Overlay Data... |          |

**Print to file**

| Windows  | Mac OS X  |
|--|---|
| Available (This function is provided by the operating system.) | Available (Rendered as PDF, PostScript, This function is provided by the operating system.) |

**Print quality**

| Windows          | Mac OS X  |
|------------------|---|
| Quality priority | Unavailable (Specify the Resolution, the number of path, and the scan direction. Under Mac OS X 10.3.x - 10.4.x, specify the paper type in combination with the print quality.) |
| Speed priority   |   |
| High speed       |   |

**Registering frequently used settings**

| Windows   | Mac OS X   |
|-----------|--|
| Available | Available (This function is provided by the operating system.) |

**Print quality (User settings)**

| Windows          | Mac OS X  |
|------------------|---|
| High quality     | Unavailable (Specify the Resolution, the number of path, and the scan direction. Under Mac OS X 10.3.x - 10.4.x, specify the paper type in combination with the print quality.) |
| Quality priority |   |
| Speed priority   |   |
| High speed       |   |

**Dithering**

| Windows      | Mac OS X     |
|--------------|--------------|
| Automatic    | -            |
| Photographic | Photographic |

| Windows    | Mac OS X            |
|------------|---------------------|
| Text       | Text                |
| Thin lines | Use error diffusion |

**Use error diffusion**

| Windows   | Mac OS X  |
|-----------|-----------|
| Available | Available |

**Color profile**

| Windows        | Mac OS X     |
|----------------|--------------|
| Optimize color | -            |
| Off            | Off          |
| Presentation   | Presentation |
| Photographic   | Photographic |
| Text           | Text         |

**Gray reproduction**

| Windows                 | Mac OS X    |
|-------------------------|-------------|
| Automatic               | Unavailable |
| K (Black) for text only |             |
| CMY + K                 |             |
| CMY + K for images only |             |

**Color balance**

| Windows   | Mac OS X    |
|-----------|-------------|
| Available | Unavailable |

**Brightness**

| Windows  | Mac OS X    |
|----------|-------------|
| -50 ~ 50 | Unavailable |

**Contrast**

|          |             |
|----------|-------------|
| Windows  | Mac OS X    |
| -50 ~ 50 | Unavailable |

**Saturation**

|          |             |
|----------|-------------|
| Windows  | Mac OS X    |
| -50 ~ 50 | Unavailable |

**Color balance: Cyan**

|          |             |
|----------|-------------|
| Windows  | Mac OS X    |
| -50 ~ 50 | Unavailable |

**Color balance: Magenta**

|          |             |
|----------|-------------|
| Windows  | Mac OS X    |
| -50 ~ 50 | Unavailable |

**Color balance: Yellow**

|          |             |
|----------|-------------|
| Windows  | Mac OS X    |
| -50 ~ 50 | Unavailable |

**Use ICM**

|           |             |
|-----------|-------------|
| Windows   | Mac OS X    |
| Available | Unavailable |

**Use ICM: ICM method**

|                   |             |
|-------------------|-------------|
| Windows           | Mac OS X    |
| By host system    | Unavailable |
| By printer driver |             |

**Use ICM: ICM intent**

|                       |             |
|-----------------------|-------------|
| Windows               | Mac OS X    |
| Graphics (Saturation) | Unavailable |



| Windows                       | Mac OS X |
|-------------------------------|----------|
| Pictures (Perceptual)         |          |
| Proof (Relative Colorimetric) |          |
| Match (Absolute Colorimetric) |          |

**Use ColorSync**

| Windows     | Mac OS X    |
|-------------|-------------|
| Unavailable | Unavailable |

**Print as bitmap**

| Windows   | Mac OS X    |
|-----------|-------------|
| Available | Unavailable |

**Change data processing**

| Windows   | Mac OS X    |
|-----------|-------------|
| Available | Unavailable |

**Separate into CMYK, then print in designated color only**

| Windows   | Mac OS X    |
|-----------|-------------|
| Available | Unavailable |

**Fit to paper size**

| Windows   | Mac OS X  |
|-----------|---|
| Available | Available (This function is provided by the operating system.) (for version 10.4 and later) |

**Scale**

| Windows   | Mac OS X   |
|-----------|--|
| Available | Available (This function is provided by the operating system.) |

**Directional Magnification**

| Windows   | Mac OS X    |
|-----------|-------------|
| Available | Unavailable |

**Layout**

| Windows   | Mac OS X   |
|---|--|
| 2 pages per sheet (2-up) (left→right) (Top→Bottom)          | 2 pages per sheet (2-up) (left→right) (Top→Bottom) (This function is provided by the operating system.)          |
| 2 pages per sheet (2-up) (right→left)                       | 2 pages per sheet (2-up) (right→left) (This function is provided by the operating system.)                       |
| 4 pages per sheet (4-up) (In rows running left to right)    | 4 pages per sheet (4-up) (In rows running left to right) (This function is provided by the operating system.)    |
| 4 pages per sheet (4-up) (In rows running right to left)    | 4 pages per sheet (4-up) (In rows running right to left) (This function is provided by the operating system.)    |
| 4 pages per sheet (4-up) (In columns starting on the left)  | 4 pages per sheet (4-up) (In columns starting on the left) (This function is provided by the operating system.)  |
| 4 pages per sheet (4-up) (In columns starting on the right) | 4 pages per sheet (4-up) (In columns starting on the right) (This function is provided by the operating system.) |
| -   | 6 pages per sheet (6-up) (In rows running left to right) (This function is provided by the operating system.)    |
| -   | 6 pages per sheet (6-up) (In rows running right to left) (This function is provided by the operating system.)    |
| -   | 6 pages per sheet (6-up) (In columns starting on the left) (This function is provided by the operating system.)  |

| Windows   | Mac OS X   |
|---|--|
| -   | 6 pages per sheet (6-up) (In columns starting on the right) (This function is provided by the operating system.)   |
| 9 pages per sheet (9-up) (In rows running left to right)      | 9 pages per sheet (9-up) (In rows running left to right) (This function is provided by the operating system.)      |
| 9 pages per sheet (9-up) (In rows running right to left)      | 9 pages per sheet (9-up) (In rows running right to left) (This function is provided by the operating system.)      |
| 9 pages per sheet (9-up) (In columns starting on the left)    | 9 pages per sheet (9-up) (In columns starting on the left) (This function is provided by the operating system.)    |
| 9 pages per sheet (9-up) (In columns starting on the right)   | 9 pages per sheet (9-up) (In columns starting on the right) (This function is provided by the operating system.)   |
| 16 pages per sheet (16-up) (In rows running left to right)    | 16 pages per sheet (16-up) (In rows running left to right) (This function is provided by the operating system.)    |
| 16 pages per sheet (16-up) (In rows running right to left)    | 16 pages per sheet (16-up) (In rows running right to left) (This function is provided by the operating system.)    |
| 16 pages per sheet (16-up) (In columns starting on the left)  | 16 pages per sheet (16-up) (In columns starting on the left) (This function is provided by the operating system.)  |
| 16 pages per sheet (16-up) (In columns starting on the right) | 16 pages per sheet (16-up) (In columns starting on the right) (This function is provided by the operating system.) |

**Draw border**

| Windows     | Mac OS X   |
|-------------|--|
| Dashed line | -  |
| -           | Single Hairline (This function is provided by the operating system.) |

| Windows | Mac OS X  |
|---------|---|
| -       | Single Thin Line (This function is provided by the operating system.) |
| -       | Double Hairline (This function is provided by the operating system.)  |
| -       | Double Thin Line (This function is provided by the operating system.) |

**Poster**

| Windows              | Mac OS X    |
|----------------------|-------------|
| 1 page into 2 sheets | Unavailable |
| 1 page into 4 sheets |             |
| 1 page into 9 sheets |             |

**Duplex**

| Windows   | Mac OS X  |
|-----------|-----------|
| Available | Available |

**Adjust Image Position: Direction**

| Windows | Mac OS X           |
|---------|--------------------|
| Left    | Long-Edge Binding  |
| Right   | -                  |
| Top     | Short-Edge Binding |

**Adjust Image Position: Top/Left margin**

| Windows  | Mac OS X    |
|----------|-------------|
| 0 - 50mm | Unavailable |

**Create margin**

| Windows   | Mac OS X    |
|-----------|-------------|
| Available | Unavailable |

**Booklet**

| Windows                  | Mac OS X    |
|--------------------------|-------------|
| Booklet 1 -Open to left  | Unavailable |
| Booklet 1 -Open to right |             |
| Booklet 2 -Open to left  |             |
| Booklet 2 -Open to right |             |

**Specifying the long edge of custom-size paper**

| Windows   | Mac OS X   |
|-----------|--|
| Available | Available (This function is provided by the operating system.) |

**Specifying the short edge of custom-size paper**

| Windows   | Mac OS X   |
|-----------|--|
| Available | Available (This function is provided by the operating system.) |

**Margin settings for custom-size paper**

| Windows   | Mac OS X   |
|-----------|--|
| Available | Available (This function is provided by the operating system.) |

**Registering custom paper sizes**

| Windows   | Mac OS X   |
|-----------|--|
| Available | Available (This function is provided by the operating system.) |

**Watermarks: Text**

| Windows   | Mac OS X    |
|-----------|-------------|
| Available | Unavailable |

**Watermarks: Bitmap**

|           |             |
|-----------|-------------|
| Windows   | Mac OS X    |
| Available | Unavailable |

**Overlay**

|           |             |
|-----------|-------------|
| Windows   | Mac OS X    |
| Available | Unavailable |

**Header/Footer**

|           |             |
|-----------|-------------|
| Windows   | Mac OS X    |
| Available | Unavailable |

**Economy Color**

|           |           |
|-----------|-----------|
| Windows   | Mac OS X  |
| Available | Available |

**Sheet-dry print delay in duplex**

|           |           |
|-----------|-----------|
| Windows   | Mac OS X  |
| Available | Available |

8

**Mixed Original Orientations**

|           |             |
|-----------|-------------|
| Windows   | Mac OS X    |
| Available | Unavailable |

**Do not print blank pages**

|           |           |
|-----------|-----------|
| Windows   | Mac OS X  |
| Available | Available |

**Reduce automatically to fit specified paper size**

|                     |   |
|---------------------|---|
| Windows             | Mac OS X  |
| Available (A4 only) | Available (This function is provided by the operating system.) (for version 10.4 and later) |

**Use preprinted/prepunched paper**

|           |             |
|-----------|-------------|
| Windows   | Mac OS X    |
| Available | Unavailable |

**Measurement Unit**

|           |  |
|-----------|--|
| Windows   | Mac OS X   |
| Available | Available (This function is provided by the operating system.) |

**Uni-directional printing only**

|           |             |
|-----------|-------------|
| Windows   | Mac OS X    |
| Available | Unavailable |

**Display Preview and Print screen**

|           |  |
|-----------|--|
| Windows   | Mac OS X   |
| Available | Available (This function is provided by the operating system.) |

**Unauthorized Copy Control**

|           |             |
|-----------|-------------|
| Windows   | Mac OS X    |
| Available | Unavailable |

**Custom Settings**

|           |             |
|-----------|-------------|
| Windows   | Mac OS X    |
| Available | Unavailable |

**When the envelope selector is set to Envelope Mode, use uni-directional printing only**

|           |           |
|-----------|-----------|
| Windows   | Mac OS X  |
| Available | Available |

**Density for plain paper printing**

|         |             |
|---------|-------------|
| Windows | Mac OS X    |
| Light   | Unavailable |

| Windows  | Mac OS X |
|----------|----------|
| Standard |          |
| Dark     |          |

**Environment Settings**

| Windows   | Mac OS X    |
|-----------|-------------|
| Available | Unavailable |

**Printable area**

| Windows  | Mac OS X    |
|----------|-------------|
| Regular  | Unavailable |
| Enlarged |             |
| Maximum  |             |



# Information about Installed Applications

## expat

Use of the software installed on this product, including the controller (hereinafter "software") and the expat Version 1.95.2 application software (hereinafter "expat 1.95.2"), is subject to the following conditions:

The product manufacturer provides warranty and support to the software of the product including expat 1.95.2 and the product manufacturer allows the initial developer of expat 1.95.2 to be free from these obligations.

Copyright © 1998, 1999, 2000 Thai Open Source Software Center Ltd  
and Clark Cooper

Permission is hereby granted, free of charge, to any person obtaining a copy of this software and associated documentation files (the "Software"), to deal in the Software without restriction, including without limitation the rights to use, copy, modify, merge, publish, distribute, sublicense, and/or sell copies of the Software, and to permit persons to whom the Software is furnished to do so, subject to the following conditions:

The above copyright notice and this permission notice shall be included in all copies or substantial portions of the Software.

THE SOFTWARE IS PROVIDED "AS IS", WITHOUT WARRANTY OF ANY KIND, EXPRESS OR IMPLIED, INCLUDING BUT NOT LIMITED TO THE WARRANTIES OF MERCHANTABILITY, FITNESS FOR A PARTICULAR PURPOSE AND NONINFRINGEMENT. IN NO EVENT SHALL THE AUTHORS OR COPYRIGHT HOLDERS BE LIABLE FOR ANY CLAIM, DAMAGES OR OTHER LIABILITY, WHETHER IN AN ACTION OF CONTRACT, TORT OR OTHERWISE, ARISING FROM, OUT OF OR IN CONNECTION WITH THE SOFTWARE OR THE USE OR OTHER DEALINGS IN THE SOFTWARE.

### ↓ Note

- Information on expat 1.95.2 is available at:  
<http://expat.sourceforge.net/>

## MD5

Copyright (c) 1991-2, RSA Data Security, Inc. Created 1991. All rights reserved.

License to copy and use this software is granted provided that it is identified as the "RSA Data Security, Inc. MD5 Message-Digest Algorithm" in all material mentioning or referencing this software or this function.

License is also granted to make and use derivative works provided that such works are identified as "derived from the RSA Data Security, Inc. MD5 Message-Digest Algorithm" in all material mentioning or referencing the derived work.

RSA Data Security, Inc. makes no representations concerning either the merchantability of this software or the suitability of this software for any particular purpose. It is provided "as is" without express or implied warranty of any kind.

These notices must be retained in any copies of any part of this documentation and/or software.

---

## NetBSD

---

### Copyright Notice of NetBSD

For all users to use this product:

This product contains NetBSD operating system:

For the most part, the software constituting the NetBSD operating system is not in the public domain; its authors retain their copyright.

The following text shows the copyright notice used for many of the NetBSD source code. For exact copyright notice applicable for each of the files/binaries, the source code tree must be consulted.

A full source code can be found at <http://www.netbsd.org/>.

Copyright © 1999, 2000 The NetBSD Foundation, Inc.

All rights reserved.

Redistribution and use in source and binary forms, with or without modification, are permitted provided that the following conditions are met:

1. Redistributions of source code must retain the above copyright notice, this list of conditions and the following disclaimer.
2. Redistributions in binary form must reproduce the above copyright notice, this list of conditions and the following disclaimer in the documentation and/or other materials provided with the distribution.
3. All advertising materials mentioning features or use of this software must display the following acknowledgment:  
This product includes software developed by the NetBSD Foundation, Inc. and its contributors.
4. Neither the name of The NetBSD Foundation nor the names of its contributors may be used to endorse or promote products derived from this software without specific prior written permission.

THIS SOFTWARE IS PROVIDED BY THE NETBSD FOUNDATION, INC. AND CONTRIBUTORS "AS IS" AND ANY EXPRESS OR IMPLIED WARRANTIES, INCLUDING, BUT NOT LIMITED TO, THE IMPLIED WARRANTIES OF MERCHANTABILITY AND FITNESS FOR A PARTICULAR PURPOSE ARE DISCLAIMED. IN NO EVENT SHALL THE FOUNDATION OR CONTRIBUTORS BE LIABLE FOR ANY DIRECT, INDIRECT, INCIDENTAL, SPECIAL, EXEMPLARY, OR CONSEQUENTIAL DAMAGES (INCLUDING, BUT NOT LIMITED TO, PROCUREMENT OF SUBSTITUTE GOODS OR SERVICES; LOSS OF USE, DATA, OR PROFITS; OR BUSINESS INTERRUPTION) HOWEVER CAUSED AND ON ANY THEORY OF LIABILITY, WHETHER IN CONTRACT, STRICT LIABILITY, OR TORT (INCLUDING NEGLIGENCE OR OTHERWISE) ARISING IN ANY WAY OUT OF THE USE OF THIS SOFTWARE, EVEN IF ADVISED OF THE POSSIBILITY OF SUCH DAMAGE.

## Authors Name List

---

All product names mentioned herein are trademarks of their respective owners.

The following notices are required to satisfy the license terms of the software that we have mentioned in this document:

- This product includes software developed by the University of California, Berkeley and its contributors.
- This product includes software developed by Jonathan R. Stone for the NetBSD Project.
- This product includes software developed by the NetBSD Foundation, Inc. and its contributors.
- This product includes software developed by Manuel Bouyer.
- This product includes software developed by Charles Hannum.
- This product includes software developed by Charles M. Hannum.
- This product includes software developed by Christopher G. Demetriou.
- This product includes software developed by Tools GmbH.
- This product includes software developed by Terrence R. Lambert.
- This product includes software developed by Adam Glass and Charles Hannum.
- This product includes software developed by Theo de Raadt.
- This product includes software developed by Jonathan Stone and Jason R. Thorpe for the NetBSD Project.
- This product includes software developed by the University of California, Lawrence Berkeley Laboratory and its contributors.
- This product includes software developed by Christos Zoulas.
- This product includes software developed by Christopher G. Demetriou for the NetBSD Project.
- This product includes software developed by Paul Kranenburg.
- This product includes software developed by Adam Glass.
- This product includes software developed by Jonathan Stone.
- This product includes software developed by Jonathan Stone for the NetBSD Project.
- This product includes software developed by Winning Strategies, Inc.
- This product includes software developed by Frank van der Linden for the NetBSD Project.
- This product includes software developed for the NetBSD Project by Frank van der Linden
- This product includes software developed for the NetBSD Project by Jason R. Thorpe.
- The software was developed by the University of California, Berkeley.
- This product includes software developed by Chris Provenzano, the University of California, Berkeley, and contributors.

---

## Original SSLeay License

---

Copyright (C) 1995-1998 Eric Young (eay@cryptsoft.com)

All rights reserved.

This package is an SSL implementation written by Eric Young (eay@cryptsoft.com).

The implementation was written so as to conform with Netscapes SSL.

This library is free for commercial and non-commercial use as long as the following conditions are aheared to. The following conditions apply to all code found in this distribution, be it the RC4, RSA, lhash, DES, etc., code; not just the SSL code. The SSL documentation included with this distribution is covered by the same copyright terms except that the holder is Tim Hudson (tjh@cryptsoft.com).

Copyright remains Eric Young's, and as such any Copyright notices in the code are not to be removed.

If this package is used in a product, Eric Young should be given attribution as the author of the parts of the library used.

This can be in the form of a textual message at program startup or in documentation (online or textual) provided with the package.

Redistribution and use in source and binary forms, with or without modification, are permitted provided that the following conditions are met:

1. Redistributions of source code must retain the copyright notice, this list of conditions and the following disclaimer.
2. Redistributions in binary form must reproduce the above copyright notice, this list of conditions and the following disclaimer in the documentation and/or other materials provided with the distribution.
3. All advertising materials mentioning features or use of this software must display the following acknowledgement:

"This product includes cryptographic software written by Eric Young (eay@cryptsoft.com)"

The word 'cryptographic' can be left out if the rouines from the library being used are not cryptographic related :-).

4. If you include any Windows specific code (or a derivative thereof) from the apps directory (application code) you must include an acknowledgement:

"This product includes software written by Tim Hudson (tjh@cryptsoft.com)"

THIS SOFTWARE IS PROVIDED BY ERIC YOUNG ``AS IS'' AND ANY EXPRESS OR IMPLIED WARRANTIES, INCLUDING, BUT NOT LIMITED TO, THE IMPLIED WARRANTIES OF MERCHANTABILITY AND FITNESS FOR A PARTICULAR PURPOSE ARE DISCLAIMED. IN NO EVENT SHALL THE AUTHOR OR CONTRIBUTORS BE LIABLE FOR ANY DIRECT, INDIRECT, INCIDENTAL, SPECIAL, EXEMPLARY, OR CONSEQUENTIAL DAMAGES (INCLUDING, BUT NOT LIMITED TO, PROCUREMENT OF SUBSTITUTE GOODS OR SERVICES; LOSS OF USE, DATA, OR PROFITS; OR BUSINESS INTERRUPTION) HOWEVER CAUSED AND ON ANY THEORY OF LIABILITY, WHETHER IN CONTRACT, STRICT

LIABILITY, OR TORT (INCLUDING NEGLIGENCE OR OTHERWISE) ARISING IN ANY WAY OUT OF THE USE OF THIS SOFTWARE, EVEN IF ADVISED OF THE POSSIBILITY OF SUCH DAMAGE.

The licence and distribution terms for any publically available version or derivative of this code cannot be changed. i.e. this code cannot simply be copied and put under another distribution licence [including the GNU Public Licence.]

---

## **TCP/IP**

---

Elmic System's KASAGO TCP/IP is installed for TCP/IP of this product.

Copyright© Elmic Wescom, Inc. 2005

---

## **JPEG LIBRARY**

---

- The software installed on this product is based in part on the work of the Independent JPEG Group.

---

## **IPS™ print language emulations**

---

Copyright© 1987-2006 Zoran Corporation. All rights reserved.

## Where to Inquire

For inquiries, contact your sales or service representative.

## Recommended Consumables

Consumables recommended for this printer are listed.

Purchase necessary consumables before your supply runs out.

For information about consumables, contact your sales or service representative.

- Print cartridges
- Ink Collector Unit

## Option and Consumables

The following options can be used with the printer:

- Paper Feed Unit TK1110

This unit feeds paper in bulk.

- Multi Bypass Tray BY1000

You can also feed paper from the bypass tray.

### Note

- For information about options and consumables, contact your service representative.



# INDEX

## A

|   |     |
|---|-----|
| About the Web Browser Help.....             | 129 |
| About This Product.....                     | 9   |
| Adj. Paper Feed.....                        | 168 |
| Alert indicator.....                        | 22  |
| An Error Occurs.....                        | 213 |
| Attaching the Multi Bypass Tray BY1000..... | 40  |
| Attaching the Options.....                  | 39  |
| Attaching the Paper Feed Unit TK1110.....   | 39  |
| Authors Name List.....                      | 313 |

## B

|  |     |
|--|-----|
| Basic Printing Procedure.....                            | 140 |
| Before Installing the Software (Network Connection)..... | 60  |
| Before Installing the Software (USB).....                | 56  |
| Bypass tray.....   | 31  |
| Bypass tray extension.....                               | 31  |

## C

|  |                                   |
|--|-----------------------------------|
| Canceling a Print Job from the Computer.....                     | 144                               |
| Canceling a Print Job on a Macintosh.....                        | 144                               |
| Canceling printing.....  | 104                               |
| Canceling Printing.....  | 104                               |
| Canceling Printing from the Status Monitor.....                  | 104                               |
| Canceling printing from the Taskbar.....                         | 105                               |
| Canceling Printing Using the [Job Reset] Key of the Printer..... | 104, 145                          |
| Canceling the Print Job.....                                     | 255, 257, 259, 261, 263, 264, 266 |
| Cartridge Almost Empty.....                                      | 272                               |
| Cartridge/Print-head Tank Empty.....                             | 273                               |
| Cautions to Take When Using in a Network.....                    | 290                               |
| Changing the Host Interface menu.....                            | 75                                |
| Changing the Paper Input Menu.....                               | 94                                |
| Changing the PCL Menu.....                                       | 186                               |
| Changing the Printer Settings.....                               | 116                               |
| Changing the System Menu.....                                    | 182                               |
| Check the power source.....                                      | 37                                |
| Checking the Computer and Installation Area.....                 | 35                                |
| Checking the Computer to be Connected.....                       | 37                                |
| Checking the Consumables.....                                    | 246                               |

|   |         |
|---|---------|
| Checking the Current Printer Driver Version.....                                      | 286     |
| Checking the Number of Printed Pages from the Control Panel.....                      | 157     |
| Checking the Printer Status.....  | 116     |
| Checking the Printer Status and Settings using the Printer's Control Panel.....       | 65      |
| Checking the Remaining Ink.....   | 191     |
| Checking the Supplied Items and Unpacking the Printer.....                            | 37      |
| Checking the Version of the Printer Driver.....                                       | 152     |
| Checking whether Bidirectional Communication is Working.....                          | 147     |
| Checking Your Computer Environment.....   | 205     |
| Cleaning.....   | 200     |
| Colors Do Not Match the Displayed Image.....  | 243     |
| Compatible Paper Types.....   | 84      |
| Conditions for Bidirectional Communication.....                                       | 99      |
| Confirming Installation.....  | 205     |
| Confirming the Connection Method.....   | 66      |
| Connecting the Computer and Installing the Software (Network Connection).....         | 60      |
| Connecting the Computer and Installing the Software (USB Connection).....             | 56      |
| Connecting the Printer via the Network.....   | 60      |
| Connecting the Printer via USB.....   | 56      |
| Control Panel.....  | 22, 248 |
| Correct Orientation of Pre-printed Paper When Loaded in the Tray 1/Tray 2/Tray 3..... | 88      |
| Correct Orientation of Preprinted Paper When Loaded in the Bypass Tray.....           | 89      |
| Counter Menu.....   | 157     |
| Cover Open.....   | 267     |
| Custom Setting.....   | 97      |

## D

|  |     |
|--|-----|
| Data In indicator.....                               | 22  |
| De-condensation.....                                 | 176 |
| Deleting Devices.....                                | 211 |
| Description for the Specified Model.....             | 15  |
| Detaching and Reattaching the Multi Bypass Tray..... | 31  |
| Dialog Boxes for Printer Settings.....               | 137 |
| Disclaimer.....                                      | 11  |
| Display.....   | 22  |
| Displaying Help from the Print dialog.....           | 149 |
| Displaying Mac Help.....                             | 149 |

|  |               |  |                    |
|--|---------------|--|--------------------|
| Displaying the [Maintenance Utility].....                    | 138           | If Bidirectional Communication is Disabled.....                    | 99                 |
| Displaying the Counter.....                                  | 157           | If Test Print Fails.....   | 209                |
| Displaying the Page Setup dialog.....                        | 138           | If You Cannot Remove Jammed Paper.....                             | 237                |
| Displaying the Print dialog.....                             | 138           | Important Notice.....  | 103                |
| Displaying the Printer Driver Settings Dialog Boxes<br>..... | 137           | Information about Installed Applications.....                      | 311                |
| Displaying the Printer Status.....                           | 109, 113, 147 | Ink.....   | 193, 269, 272, 273 |
| Displaying the Status Monitor.....                           | 147           | Ink Collector Unit.....  | 21                 |
| Displaying Top Page.....                                     | 114           | Ink Collector Unit Almost Full.....                                | 277                |
| Disposing.....   | 203           | Ink collector unit cover.....                                      | 21                 |
| Duplex Unit.....   | 22            | Ink Collector Unit Full.....                                       | 277                |
| Duplex Unit Not Detected.....                                | 271           | Ink Collector Unit Not Detected.....                               | 275                |
| <b>E</b>   |               | Inkjet plain paper.....  | 84                 |
| Electromagnetic Interference.....                            | 291           | Install.....   | 68, 77, 82         |
| Enter key.....   | 22            | Installing the Drivers for Network Connection.....<br>.....        | 76                 |
| Envelope selector.....                                       | 20            | Installing the PCL or RPCS Raster Printer Driver<br>(Network)..... | 77                 |
| Envelope Selector Position Mismatch.....                     | 279           | Installing the PCL or RPCS raster printer driver (USB)<br>.....    | 68                 |
| Envelopes.....   | 84            | Installing the Print Cartridges.....                               | 40                 |
| Error.....   | 248           | Installing the Printer Driver under Mac OS X.....<br>.....         | 133                |
| Escape key.....  | 22            | Installing User Guide.....   | 16                 |
| Ethernet port.....   | 22            | Interpreting the Configuration Page.....                           | 65                 |
| expat.....   | 311           | Introduction.....  | 9                  |
| <b>F</b>   |               | <b>J</b>   |                    |
| Feed.....  | 215           | Job Reset.....   | 104                |
| Files.....   | 154, 287      | Job Reset key.....   | 22                 |
| Form Feed key.....   | 22            | JPEG LIBRARY.....  | 315                |
| <b>G</b>   |               | <b>L</b>   |                    |
| Glossy paper.....  | 84            | Left cover.....  | 20                 |
| Guide board.....   | 21            | List/Test Print Menu.....  | 65                 |
| Guide to Components.....                                     | 20            | Loadable Paper Sizes and Quantities.....                           | 84                 |
| <b>H</b>   |               | Loading paper.....   | 44                 |
| Handling Print Cartridges.....                               | 195           | Loading Paper.....   | 258                |
| Hardware.....  | 131           | Loading Paper into Bypass Tray (optional).....                     | 53                 |
| Head Position.....   | 166           | Loading Paper into Tray 1.....                                     | 44                 |
| Head-cleaning.....   | 162           | Loading Paper into Tray 2/Tray 3.....                              | 49                 |
| Head-flushing.....   | 165           | Loading Paper Larger than A4 (Letter)(tray1).....<br>.....         | 46                 |
| Host Interface Menu.....                                     | 73            | Loading Paper Larger than A4/Letter (Tray 2/Tray<br>3).....        | 51                 |
| How to Use User Guide.....                                   | 17            | Loading Precautions.....   | 87                 |
| <b>I</b>   |               |  |                    |
| If a Message Appears during Installation.....                | 247           |  |                    |

|  |          |  |     |
|--|----------|--|-----|
| Locking the Keys.....                                | 189      | Opening Help.....  | 149 |
| <b>M</b>   |          | Opening the Printer Properties Dialog Box.....                 | 97  |
| Machine Body.....                                    | 20       | Opening the Printing Preferences Dialog Box.....               | 97  |
| Machine Rear.....                                    | 21       | Operating System.....  | 131 |
| Maintenance Menu.....                                | 159      | Option (Bypass tray).....                                      | 295 |
| Making Printer Settings Using the Control Panel..... | 25       | Option (Paper Feed Unit).....                                  | 294 |
| Manuals.....   | 155, 289 | Options.....   | 30  |
| Manuals for This Printer.....                        | 13       | Options and consumables.....                                   | 318 |
| Menu.....  | 116      | Original SSLeay License.....                                   | 314 |
| Menu Chart.....                                      | 25       | Other Problems.....  | 244 |
| Menu key.....  | 22       | Out of Printable Temperature Range.....                        | 278 |
| Messages.....  | 248      | Output ramp.....   | 20  |
| Moving.....  | 201      | Output ramp extension.....                                     | 20  |
| Moving a Long Distance.....                          | 201      | <b>P</b>   |     |
| Moving a Short Distance.....                         | 201      | Paper.....   | 84  |
| Multi Bypass Tray BY1000.....                        | 31       | Paper Feed Unit TK1110.....                                    | 30  |
| Multi-tab.....                                       | 97       | Paper feed wheel.....  | 21  |
| <b>N</b>   |          | Paper Handling Precautions.....                                | 87  |
| NetBSD.....  | 312      | Paper Input Menu.....  | 94  |
| Network Interface Error.....                         | 279      | Paper Is Not Fed or Delivered Normally.....                    | 215 |
| No Paper/Tray Not Detected (Bypass Tray).....        | 258      | Paper Jam.....   | 217 |
| No Paper/Tray Not Detected (Tray 1).....             | 254      | Paper Size Mismatch/Paper Type Mismatch (AutoTray Select)..... | 265 |
| No Paper/Tray Not Detected (Tray 2/Tray 3).....      | 256      | Paper Size Mismatch/Paper Type Mismatch (Bypass Tray).....     | 263 |
| No Response from Printer.....                        | 254      | Paper Size Mismatch/Paper Type Mismatch (Tray 1).....          | 260 |
| No-Fuss Head Cleaning.....                           | 163      | Paper Size Mismatch/Paper Type Mismatch (Tray 2/Tray 3).....   | 261 |
| Non-compatible paper.....                            | 91       | Paper Storage Precautions.....                                 | 90  |
| Notes on the Installation (Network Connection).....  | 63       | Paper Type Precautions.....                                    | 90  |
| Notes on the Installation (USB Connection).....      | 57       | Paper Will Not Feed Even When the Power Is On.....             | 213 |
| Notifying the Printer Status by E-mail.....          | 117      | PCL Menu.....  | 184 |
| Nozzle Check.....                                    | 160      | PCL Printer Drivers.....                                       | 288 |
| <b>O</b>   |          | Performing Maintenance using the Control Panel.....            | 159 |
| Online key.....                                      | 22       | Plain paper.....   | 84  |
| Opening from an Application.....                     | 98       | Plugging in the Power Cord and Turning the Power On.....       | 42  |
| Opening from Printer Status Error Messages.....      | 19       | Positions Do Not Match the Displayed Image.....                | 243 |
| Opening from the CD-ROM.....                         | 18       | Power Cannot Be Turned On.....                                 | 213 |
| Opening from the Icon.....                           | 18       | Power inlet.....   | 21  |
| Opening from the Printer Driver.....                 | 18       |  |     |
| Opening from the Start Menu.....                     | 18       |  |     |

|  |                              |
|--|------------------------------|
| Power key.....   | 22                           |
| Print cartridge.....                                       | 20                           |
| Print Cartridge End LED.....                               | 22                           |
| Print Cartridge(s) Not Detected.....                       | 269                          |
| Print results are not satisfactory.....                    | 241                          |
| Printable area.....  | 92                           |
| Printer Body.....  | 292                          |
| Printer Driver.....  | 68, 77                       |
| Printer Driver Cannot Be Installed.....                    | 207                          |
| Printer Driver Settings.....                               | 296                          |
| Printer Error.....   | 278                          |
| Printer Properties Dialog Box.....                         | 97, 101, 137                 |
| Printing.....  | 101                          |
| Printing a Configuration Page.....                         | 54                           |
| Printing a document using [Data security for copying]..... | 102                          |
| Printing a Document Using [Mask type].....                 | 102                          |
| Printing by Form Feed.....                                 | 255, 256, 260, 262, 264, 265 |
| Printing on Paper in a Paper Tray.....                     | 141                          |
| Printing on Various Paper Types.....                       | 140                          |
| Printing Will Not Start.....                               | 213                          |
| Printing with the Bypass Tray.....                         | 143                          |
| Prints are Unsatisfactory.....                             | 241                          |

## Q

|                                |         |
|--------------------------------|---------|
| Quick Install for Network..... | 63, 205 |
| Quick Install for USB.....     | 57, 205 |

## R

|  |     |
|--|-----|
| Receiving Notification of Print Job Status via the Status Monitor..... | 109 |
| Recommended consumables.....   | 317 |
| Recommended Functions.....   | 33  |
| Registration.....  | 170 |
| Removing paper jammed around the guide board.....                      | 230 |
| Removing Paper Jammed in the Duplex Unit.....                          | 234 |
| Removing Paper Jammed in the Multi Bypass Tray (optional).....         | 223 |
| Removing Paper Jammed in the Rear Unit.....                            | 222 |
| Removing Paper Jammed in Tray 1.....                                   | 218 |
| Removing Paper Jammed in Tray 2/Tray 3 (optional).....                 | 220 |

|  |          |
|--|----------|
| Removing Paper Jammed under the Top Cover..... | 227      |
| Removing the User Guide.....                   | 19       |
| Replacing an Ink Collector Unit.....           | 197      |
| Replacing a Print Cartridge.....               | 191, 193 |
| Restricting Printer Functions.....             | 189      |
| Right front cover.....                         | 20       |
| RPCS Raster Printer Drivers.....               | 154, 287 |

## S

|  |              |
|--|--------------|
| Selecting the Control Panel Language.....  | 187          |
| Setting Up a Client Computer.....  | 71           |
| Setting Up a Server.....   | 70           |
| Setting Up the Hardware.....   | 35           |
| Sharing the Printer.....   | 70           |
| SmartDeviceMonitor for Client.....   | 82, 110, 288 |
| SNMP.....  | 130          |
| Software Cannot Be Installed.....  | 205          |
| Software on the CD-ROM.....  | 287          |
| Specifications.....  | 292          |
| Specifying Settings on [Accessories] Tab.....  | 99           |
| Specifying Settings on the Control Panel.....  | 61           |
| Specifying System Settings using the Control Panel.....                              | 178          |
| Specifying the Client Computer Settings.....   | 112          |
| Specifying the Interface and Network Settings using the Printer's Control Panel..... | 73           |
| Specifying the Paper Settings using the Printer's Control Panel.....                 | 94           |
| Specifying the Print Server.....   | 111          |
| Specifying the Printer Settings on a Macintosh.....                                  | 134          |
| Specifying the Settings for Monitoring the Printer ...                               | 112          |
| Status Monitor.....  | 104, 254     |
| Status Monitor Does Not Open.....  | 254          |
| Status Monitor Errors.....   | 254          |
| Symbols.....   | 16           |
| System Menu.....   | 178          |
| System Requirements.....   | 131          |

## T

|   |         |
|---|---------|
| TCP/IP.....                                     | 77, 315 |
| The area where the printer is to be placed..... | 35      |
| Thick paper.....                                | 84      |

|   |     |                       |     |
|---|-----|-----------------------|-----|
| Top cover.....                                  | 20  | Where to Inquire..... | 316 |
| Trademarks.....                                 | 9   |                       |     |
| Tray 1.....                                     | 20  |                       |     |
| Tray 2.....                                     | 30  |                       |     |
| Tray 2 cover.....                               | 30  |                       |     |
| Tray 3.....                                     | 30  |                       |     |
| Tray 3 cover.....                               | 30  |                       |     |
| Troubleshooting.....                            | 248 |                       |     |
| Two Types of Printer Properties Dialog Box..... | 97  |                       |     |

## U

|  |          |
|--|----------|
| Unauthorized Copy Control.....                                 | 102      |
| Uninstalling.....  | 210      |
| Uninstalling the Printer Driver.....                           | 152, 210 |
| Unlocking the Keys.....  | 189      |
| up arrow, down arrow keys.....                                 | 22       |
| Updating the Firmware.....                                     | 285      |
| USB Connection is not Automatically Detected.....              | 208      |
| USB slot.....  | 21       |
| Used Ink Collector Unit.....                                   | 277      |
| User's Notes.....  | 11       |
| Using as the Windows Network Printer.....                      | 81       |
| Using DHCP.....  | 290      |
| Using Notification via SmartDeviceMonitor for Client.....      | 111      |
| Using SmartDeviceMonitor for Client.....                       | 110      |
| Using the [Form Feed] Key to Remove Jammed Paper.....          | 217      |
| Using the LPR Port.....  | 80       |
| Using the Printer via a USB Connection from a Macintosh.....   | 134      |
| Using the Printer via Network Connection from a Macintosh..... | 135      |
| Using the SmartDeviceMonitor for Client Port.....              | 77       |
| Using the Standard TCP/IP Port.....                            | 78       |
| Using the Status Monitor.....                                  | 109      |
| Using Web Browser.....   | 114      |

## V

|           |    |
|-----------|----|
| Vent..... | 21 |
|-----------|----|

## W

|   |     |
|---|-----|
| Wheel.....                                    | 31  |
| When Not Using for a Long Period of Time..... | 204 |

---

MEMO



**GelSprinter GX e5550N** User Guide

